

GE Healthcare

Giraffe[®] OmniBed

Service Manual



To reorder this manual, order kit:

- 6600-0834-801 (USA)
- 6600-0834-802 (INTL)

Copyright 2001 by Datex-Ohmeda, Inc.
All rights reserved.

6600-0343-000 104

© 2001 by Datex-Ohmeda, Inc.

All rights reserved. General Electric Company reserves the right to make changes in specifications and features shown herein, or discontinue the product described at any time without notice or obligation. Contact your GE Representative for the most current information. Giraffe and Panda® are registered trademarks owned by Datex-Ohmeda, Inc. GE and GE Monogram are trademarks of General Electric Company. All other company and product names mentioned may be trademarks of the companies with which they are associated.

Table of Contents

About this Manual.....	xv
Scope and Intended Users	xv
Conventions.....	xv
References	xvi
Symbol Definitions.....	xvi
User Responsibility	xviii
Important.....	xviii
Technical Competence.....	xix
Warnings.....	xix
Cautions	xx
Chapter 1: Functional Description	1
1.1 Control Board	1
1.2 Relay Board	3
1.3 Display Driver Board / EL Display	4
1.4 LED Board.....	5
1.5 Power Supply.....	5
1.6 Peripheral Components.....	5
1.6.1 Rail and Heater Door Switches.....	6
1.7 DataLink Option	6
1.8 Servo Controlled Oxygen Option.....	7
1.9 Humidifier	9
Chapter 2: Service Checkout.....	11
2.1 Setup	11
2.2 Mechanical Checks.....	11
2.3 Controller Checks.....	12
2.4 Humidity Check	14
2.5 Servo Controlled Oxygen Check.....	14
2.5.1 Leak Check	14
2.5.2 Pre-use Checkout.....	14
2.5.3 Supply Valve Leak Test	15

2.6 Scale Check.....	16
2.6.1 Mechanical Check.....	16
2.6.2 Weight Checks.....	16
2.6.2.1 Center Weight Check.....	16
2.6.2.2 Off Center Weight Check.....	17
2.7 Other Accessory Checks.....	17
2.8 Cable Connections and Mechanical Controls.....	18
Chapter 3: Calibration and Maintenance	21
3.1 Service Maintenance Schedule.....	21
3.2 Special Tools	23
3.3 System Calibration.....	23
3.4 Line Voltage Calibration	24
3.5 Humidifier Calibration	25
3.6 Servo Controlled Oxygen Calibration	26
3.7 Scale Calibration.....	26
3.8 Leakage Current	27
3.9 Ground Resistance Check.....	27
Chapter 4: Troubleshooting	29
4.1 Startup Sequence.....	29
4.2 Service Screen.....	30
4.3 Alarm Messages.....	34
4.3.1 "Air Probe Failure" Alarm.....	34
4.3.2 "Air Temp >38C" or "Air Temp >40C" Alarm.....	34
4.3.3 "Baby Hot" or "Baby Cold" Alarm	34
4.3.4 "Baby Mode Disabled" Alarm.....	35
4.3.5 "Baby Probe 1 Failure" or "Baby Probe 2 Failure" Alarm.....	35
4.3.6 "Bad Membrane Switch" Alarm	35
4.3.7 "Bed Heater Failure" Alarm.....	36
4.3.8 "Bed Up/Down Pedal Failure" Alarm	36
4.3.9 "Bed Up/Down Pedal Switches Disabled" Alarm	36
4.3.10 "Canopy Pedal Disabled" Alarm.....	37
4.3.11 "Canopy Pedal Failure" Alarm.....	37
4.3.12 "Canopy Pedal Pressed" Alarm.....	37
4.3.13 "Down Pedal Pressed" Alarm	37
4.3.14 "Fan Always in High Speed" Alarm.....	38
4.3.15 "Fan Failure" Alarm.....	38
4.3.16 "Heater Doors Not Closed" Alarm.....	39
4.3.17 "Heater Doors Not Opened" Alarm.....	39
4.3.18 "Humidifier Failure" Alarm	40

4.3.19 "In Transition - Heat Off" Alarm.....	41
4.3.20 "Motor Drive Failure" Alarm	41
4.3.21 Power Failure (LED Indicator)	42
4.3.22 "Radiant Heater Failure" Alarm.....	42
4.3.23 "Temperature out of Calibration" Alarm.....	42
4.3.24 "Up Pedal Pressed" Alarm.....	43
4.4 Error Codes.....	43
4.4.1 System Failure 0	43
4.4.2 System Failure 1	44
4.4.3 System Failure 2	44
4.4.4 System Failure 3	44
4.4.5 System Failure 5	44
4.4.6 System Failure 6	45
4.4.7 System Failure 7	45
4.4.8 System Failure 8	45
4.4.9 System Failure 11.....	45
4.4.10 System Failure 12	46
4.4.11 System Failure 13	46
4.4.12 System Failure 14	46
4.4.13 System Failure 15	46
4.4.14 System Failure 16	48
4.4.15 System Failure 17	48
4.4.16 System Failure 18.....	48
4.4.17 System Failure 19.....	49
4.4.18 System Failure 20.....	49
4.4.19 System Failure 22	49
4.4.20 System Failure 23	50
4.4.21 System Failure 25.....	50
4.4.22 System Failure 26.....	50
4.4.23 System Failure 27	51
4.4.24 System Failure 28.....	51
4.4.25 System Failure 29.....	51
4.4.26 System Failure 30.....	51
4.4.27 System Failure 33.....	52
4.4.28 System Failure 34.....	52
4.4.29 System Failure 35.....	52
4.4.30 System Failure 36	52
4.4.31 System Failure 37	53
4.4.32 System Failure 38	53
4.4.33 System Failure 50.....	53
4.4.34 System Failure 51.....	53
4.4.35 System Failure 52.....	54
4.4.36 System Failure 53.....	54
4.4.37 System Failure 55.....	54

4.4.38 System Failure 60	54
4.4.39 System Failure 98	54
4.4.40 System Failure 99	54
4.5 Troubleshooting Symptoms	55
4.6 Additional Troubleshooting Tips	58
4.6.1 Raising and Lowering the Canopy or Elevating Base	58
4.6.2 Incubator Heaters and Bed Safety Thermostat	59
4.6.3 Radiant Heater	59
4.6.4 Power Supplies	59
4.6.5 Switches/Thermostat	60
4.6.6 Humidifier Heater/Safety Thermostat	61
4.6.7 Compartment Air Probe and Patient Probes	61
4.6.8 Heat Sink Sensor Thermistor	62
4.6.9 E-base Motor and Canopy Motor	62
4.6.10 Rail Lift Belt Failure	63
4.6.11 Troubleshooting the 50 Pin Ribbon Cable	64
4.6.12 Troubleshooting the Toroidal Transformer	64
4.6.13 Interpreting Serial Numbers	64
4.7 Servo Controlled Oxygen	65
4.7.1 Servo Controlled Oxygen Service Screen	65
4.7.2 Servo Controlled Oxygen Alarm Messages	66
4.7.3 Servo Controlled Oxygen Troubleshooting Tips	69
4.7.3.1 Check Supply Valves and Endcap Safety Valve	69
4.7.3.2 Check Calibration Valve/Calibration Fan	69
4.7.3.3 Check Cooling Fan	70
4.7.3.4 Sensor Housing Temperature Sensor Temperature to Resistance Curve	70
Chapter 5: Repair Procedures	71
5.1 Canopy Removal for Replacement	71
5.2 Servicing the Canopy Seals	76
5.2.1 Servicing Original Canopy Seals	77
5.2.2 Servicing Enhanced Canopy Seals	89
5.3 Porthole Door Replacement	90
5.4 Right Rail Assembly Repair Procedures	90
5.4.1 Removing the Right Upright (Motor Side)	90
5.4.2 Removing the Left Upright	94
5.4.3 Right Rail Internal Repairs	96
5.4.3.1 Removing the Inner Rail Assembly	96
5.4.3.2 Replacing Rollers and Tension Springs	97
5.4.3.3 Separating the Lift Rail from the Belt Channel	98
5.4.3.4 Replacing the Rail Drive Belt	98
5.4.3.5 Replacing the Rail Buoyancy Springs	99
5.4.3.6 Replacing the Slip Clutch or Motor Roll Pin	100

5.4.4 Reassembling the Right Upright	100
5.5 Left Rail Internal Repairs	102
5.5.1 Removing the Inner Rail Assembly.....	102
5.5.2 Replacing the Rail Buoyancy Springs	103
5.5.3 Replacing Rollers, Tension Springs, and Cable Carrier Links.....	104
5.5.4 Reassembling the Left Upright	104
5.5.5 Replacement of the Left Upright Heater Wire Harness/Cable Carrier Assembly.....	106
5.5.5.1 Removing and Disassembling the Rail	106
5.5.5.2 Removing the Old Harness Assembly from the Left Rail.....	106
5.5.5.3 Reinstalling the New Harness on the Left Rail	108
5.5.5.4 Removing the Old Harness from the Cable Carrier Channel.....	109
5.5.5.5 Installing the New Harness on the Cable Carrier Channel.....	109
5.5.5.6 Reassembly	111
5.6 Radiant Heater Assembly Repair Procedures.....	111
5.6.1 Removing the Canopy/Heater Assembly	111
5.6.1.1 Realigning the Canopy	113
5.6.2 Replacing the Radiant Heater	114
5.6.3 Heater Door Spool Assembly.....	116
5.6.4 Heater Door Cable Adjustment.....	117
5.6.5 Spring Tube Assembly Replacement.....	118
5.7 Compartment Air Probe Repairs	121
5.8 Removing the Upper End Cap Spring	122
5.9 Lower Unit Repairs.....	123
5.9.1 Removing the Chassis Cover with the Storage Drawer in Place.....	123
5.9.2 Incubator Fan, Fan Motor, and Optical Fan Sensor.....	124
5.9.3 Incubator Heater Replacement.....	126
5.9.3.1 To Remove the Incubator Heater Closest to the Foot of the Bed	127
5.9.3.2 To Remove the Incubator Heater Closest to the Head of the Bed.....	127
5.9.4 Elevating Base	128
5.9.5 Chassis Replacement.....	129
5.9.6 Bed Up/Down Pedal Switch.....	130
5.9.7 Canopy Pedal Switch.....	130
5.9.8 Canopy Membrane Switch Replacement	130
5.10 Bed Tilt Brake Pad Replacement	132
5.11 Caster Replacement	133
5.12 Humidifier Assembly Repairs.....	133
5.12.1 Tips for Repairing an Old Style Unit.....	134
5.12.2 Disassembly.....	134
5.12.3 Reassembly	136
5.13 Controller and Display Module Procedures	137
5.13.1 Display Module	137
5.13.2 Probe Panel	138

5.13.2.1 Battery.....	139
5.13.3 Controller Components.....	140
5.13.3.1 Control Board.....	141
5.13.3.2 Relay Board.....	141
5.13.3.3 Solid State Relays.....	141
5.13.3.4 Power Supply.....	141
5.13.3.5 Toroidal Transformer.....	142
5.13.3.6 Canopy Lift Motor, ISO Transformer, Circuit Breakers, Power Switches, and Power Outlets.....	142
5.14 Servo Controlled Oxygen Service Procedures.....	143
5.14.1 Installing Oxygen Sensors.....	143
5.14.2 Replacing the Vent Screen.....	143
5.14.3 Sensor Housing Repairs.....	144
5.14.3.1 Sensor Housing Repairs: Boards, Calibration Fan Assembly, and Sensor Plug Assembly.....	144
5.14.3.2 Sensor Housing Repairs: Calibration Valve.....	145
5.14.4 Valve Housing Repairs.....	146
5.14.4.1 Valve Housing Repairs: Regulator Assembly.....	146
5.14.4.2 Valve Housing Repairs: Supply Valves.....	147
5.14.5 Endcap Safety Valve.....	147
5.14.6 Servo Oxygen Board Repairs.....	148
Chapter 6: Illustrated Parts.....	149
6.1 Exploded Views.....	149
6.1.1 Probe Housing, Display Module, and Electrical Enclosure.....	150
6.1.2 Bed and Side Panels.....	158
6.1.3 Radiant Heater and Canopy.....	164
6.1.4 Chassis.....	172
6.1.5 Humidifier.....	176
6.1.6 Elevating Base.....	178
6.1.7 Uprights and Lift Rail Components.....	180
6.1.8 Compartment Air Probe.....	192
6.1.9 Servo Control Oxygen.....	194
6.1.10 Storage Drawer.....	202
6.2 Accessories.....	211
6.3 Labels.....	212
6.4 PCB Layouts.....	217
6.5 Wiring Diagrams.....	221
Appendix A: Compartment and Skin Probe Characteristics.....	233
Appendix B: Specifications.....	235
B.1 Power Requirements.....	235

B.2 Accessory Outlets.....	235
B.3 Standards.....	235
B.4 Operating Environment.....	236
B.5 Storage Conditions.....	236
B.6 User Control Settings.....	236
B.7 Alarms.....	236
B.8 Performance.....	237
B.8.1 System.....	237
B.8.2 Humidity.....	237
B.8.3 Servo Control Oxygen.....	237
B.9 Weight Scale.....	238
B.10 Mechanical Specifications.....	238
B.10.1 Accessories.....	238
Appendix C: RS-232 Serial Data	239
C.1 RS-232 Connector.....	239
C.2 Data Stream.....	239
C.3 Nurse Call.....	240

List of Figures

Figure 1-1 Block Diagram	2
Figure 1-2 Humidifier	9
Figure 2-1 Connections and Controls.....	18
Figure 3-1 Control Board Test Points	22
Figure 4-1 First Service Screen	30
Figure 4-2 Second Service Screen	31
Figure 4-3 Status Menu.....	31
Figure 4-4 Switch Diagnostic Diagram.....	32
Figure 4-5 Pedal Screen.....	32
Figure 4-6 Service Screen	33
Figure 4-7 Servo Controlled Oxygen Service Screen.....	65
Figure 5-1 Heater Housing Cover and Soffit	72
Figure 5-2 Original Seal Parts.....	73
Figure 5-3 Nuts.....	73
Figure 5-4 Access Holes.....	74
Figure 5-5 Canopy, Bracket, and Heater Housing.....	74
Figure 5-6 Two People Needed for this Step.....	75
Figure 5-7 Canopy Seals and Extrusions	76
Figure 5-8 Wedging a Blunt Object to Keep Seal Open	77
Figure 5-9 Enhanced Seal Parts.....	78
Figure 5-10 West Side Seal Parts.....	79
Figure 5-11 Using North Seal to Help Position Washers	79
Figure 5-12 Seal Cross-section.....	80
Figure 5-13 North Seal Parts	81
Figure 5-14 Beveled Side of North Spacer Toward Canopy.....	81
Figure 5-15 Hole Fill Assembly (2x) for Canopies with Six Holes across North End	82
Figure 5-16 South Seal Parts.....	83
Figure 5-17 South Corner Parts.....	84
Figure 5-18 North Corner Parts.....	84
Figure 5-19 Installing Rail Spacers.....	85
Figure 5-21 Soffit.....	87

Figure 5-22 Trimming the Soffit.....	87
Figure 5-23 Untrimmed and Trimmed Soffit.....	88
Figure 5-24 Disconnecting Heater Door Cable.....	91
Figure 5-25 Upright Decorative Strips, End Caps, and Wire Covers.....	92
Figure 5-26 Removing the Lift Motor.....	93
Figure 5-27 Display Module Disassembly.....	93
Figure 5-28 Right Upright Disassembly.....	96
Figure 5-29 Rollers and Tensioning Spring.....	97
Figure 5-30 Replacing the Drive Belt.....	98
Figure 5-31 Replacing the Rail Buoyancy Springs.....	99
Figure 5-32 Left Inner Rail.....	102
Figure 5-33 Left Rail Springs and Spools.....	103
Figure 5-34 Re-attaching the Upright.....	104
Figure 5-35 Cable Guard Latch.....	107
Figure 5-36 3-pin MAT-N-LOK Connector and Bushing.....	107
Figure 5-37 Cable Tie.....	108
Figure 5-38 Connector Drawing.....	109
Figure 5-39 Opened Cable Guard Latches.....	109
Figure 5-40 Correct and Incorrect Cable Tie Usage.....	110
Figure 5-41 Lift Rail and Cable Carrier Channel Together.....	110
Figure 5-42 Canopy Alignment.....	112
Figure 5-43 Radiant Heater Disassembly.....	114
Figure 5-44 Heater Door Cable Adjustment.....	116
Figure 5-45 Securing String to the Spring Tube.....	118
Figure 5-46 Removal of the Lower M5 Nut.....	119
Figure 5-47 Dog Point of the Set Screw.....	120
Figure 5-48 Compartment Air Probe Disassembly.....	121
Figure 5-49 Top Rail End Cap.....	122
Figure 5-50 Bed Disassembly.....	124
Figure 5-51 Heat Sink and Fan.....	125
Figure 5-52 Fan Motor.....	125
Figure 5-53 Elevating Base.....	126
Figure 5-54 Chassis Bottom Cover.....	129
Figure 5-55 Replacing the Tilt Brake Pad.....	132
Figure 5-56 Humidifier Parts.....	135
Figure 5-57 Display Module.....	137
Figure 5-58 Probe Panel.....	138

Figure 5-59 Electronics Enclosure.....	140
Figure 5-60 Installing Sensors.....	143
Figure 5-61 Sensor Housing.....	144
Figure 5-62 Valve Housing.....	146
Figure 5-63 Endcap Safety Valve.....	147
Figure 6-1 Probe Panel Assembly.....	151
Figure 6-2 Display Module.....	153
Figure 6-3 Electrical Enclosure.....	155
Figure 6-4 Humidifier Transformer and RS232 Option.....	157
Figure 6-5 Bed.....	159
Figure 6-6 Side Panel (East/West).....	161
Figure 6-7 Rear (North) and Front (South) Wall.....	163
Figure 6-8 Radiant Heater.....	165
Figure 6-9 Canopy.....	167
Figure 6-10 Original Canopy Seal Parts.....	168
Figure 6-11 Enhanced Canopy Seal Parts.....	169
Figure 6-12 Heater Doors.....	171
Figure 6-13 Upper Chassis.....	173
Figure 6-14 Lower Chassis.....	175
Figure 6-15 Humidifier Assembly.....	177
Figure 6-16 Base and Elevating Column.....	179
Figure 6-17 Right (East) Upright Parts, Motor Side (Complete East Rail Assembly: 6600-0290-850) 181	
Figure 6-18 Belt Channel - 1 (Lift Motor Side).....	183
Figure 6-19 Belt Channel - 2 (Lift Motor Side).....	185
Figure 6-20 Lift Rail (Both Sides).....	187
Figure 6-21 Rail End Caps.....	189
Figure 6-22 Left (West) Upright (Complete West Rail Assembly: 6600-0290-851).....	191
Figure 6-23 Compartment Air Probe.....	193
Figure 6-24 Servo Control Oxygen Sensor Housing Assembly (Servo O2 Upgrade Kit 6600-0678-800) 195	
Figure 6-25 Servo Control Oxygen Valve Housing.....	197
Figure 6-26 Expansion Chamber/Heatsink Vent.....	198
Figure 6-27 Servo Control Oxygen Cooling Fan.....	199
Figure 6-28 Servo Control Oxygen PC Board.....	200
Figure 6-29 Manifold Endcap Safety Valve.....	201
Figure 6-30 Storage Drawer.....	202

Figure 6-31 Instrument Shelf (6600-0865-700)	203
Figure 6-32 Monitor Shelf (6600-0824-800)	204
Figure 6-33 E-Cylinder Holder (6600-0836-800).....	205
Figure 6-34 Tubing Management Arm (6600-0837-800)	206
Figure 6-35 Dovetail Mount DIN Rail (6600-0659-803)	207
Figure 6-36 Silo Support Assembly (6600-0853-800)	208
Figure 6-37 Rotating I.V. Pole Assembly (6600-0851-800)	209
Figure 6-38 Dovetail Extension (6600-0852-800)	210
Figure 6-39 Control Board (6600-0212-850).....	217
Figure 6-40 Display Driver Board (6600-0213-850).....	218
Figure 6-41 Relay Board (6600-0214-850) Revision Level 10 or Higher.....	219
Figure 6-42 Relay Board (6600-0214-850) Revision Level 9 or Lower.....	220
Figure 6-43 Wiring Diagram: Control Board.....	221
Figure 6-44 Wiring Diagram: Elevating Base and Canopy Lift Rails.....	222
Figure 6-45 Wiring Diagram: Electrical Enclosure	223
Figure 6-46 Wiring Diagram: Graphics Display.....	224
Figure 6-47 Wiring Diagram: Incubator Relay Board Rev 10 or Higher	225
Figure 6-48 Wiring Diagram: Incubator Relay Board 9 or Lower	226
Figure 6-49 Wiring Diagram: Radiant Heater Relay Board 10 or Higher.....	227
Figure 6-50 Wiring Diagram: Radiant Heater Relay Board 9 or Lower	228
Figure 6-51 Wiring Diagram: Servo Humidifier Relay Board 10 or Higher	229
Figure 6-52 Wiring Diagram: Servo Humidifier Relay Board 9 or Lower	230
Figure 6-53 Wiring Diagram: Servo Control Oxygen.....	231

About this Manual

Scope and Intended Users

This service manual describes the repair and maintenance of the Giraffe OmniBed.

The intended users for this service manual are authorized service personnel.

Conventions

Various types of pictures or icons are used in this service manual wherever they reinforce the printed message to alert you to potential safety hazards in one of the following ways:



WARNING:

A WARNING statement is used when the possibility of injury to the patient or the operator exists.



CAUTION:

A CAUTION statement is used when the possibility of damage to the equipment exists.



SENSITIVE TO ELECTROSTATIC DISCHARGE CAUTION

An Electrostatic Discharge (ESD) Susceptibility symbol is displayed to alert service personnel that the part(s) are sensitive to electrostatic discharge and that static control procedures must be used to prevent damage to the equipment.

NOTE: A note provides additional information to clarify a point in the text.

IMPORTANT: An Important statement is similar to a note, but is used for greater emphasis.

References







The following table lists the part numbers for the manual kit in each language containing the Giraffe OmniBed Operation and Maintenance Manual and other documents pertaining to Giraffe OmniBed:











Language	Manual Kit
Czech	M1141763
Danish	6600-0835-817
Dutch	6600-0835-810
English UK	6600-0835-812
English US	6600-0835-801
Estonian	M1141752
French	6600-0835-802
German	6600-0835-804
Italian	6600-0835-805

Language	Manual Kit
Japanese	6600-0835-807
Korean	M1141805
Norwegian	6600-0835-818
Polish	M1141760
Romanian	M1141768
Russian	M1141766
Spanish	6600-0835-803
Swedish	6600-0835-806
Turkish	M1141750

Symbol Definitions

This section identifies the symbols that are displayed on the Giraffe OmniBed:

Symbol	Description
	Temperature Alarm
	Heater
	Airflow Curtain
	Fan
	Canopy Up/Down (used in conjunction with up/down arrows)
	Environmental Probe

Symbol	Description
	Scale
	Patient Oxygen
	Alarm Silence
	Patient
	Protective Ground
	Opening Giraffe Humidifier Reservoir
	Maximum Water Level for Humidifier
	Power Disconnect
	Maximum Weight
	Caution: Hot Surface
	Setup Screen

User Responsibility

This Product will perform in conformity with the description thereof contained in this service manual and accompanying labels and/or inserts, when assembled, operated, maintained and repaired in accordance with the instructions provided. This Product must be checked periodically. A defective Product should not be used. Parts that are broken, missing, plainly worn, distorted or contaminated should be replaced immediately. Should such repair or replacement become necessary, GE Healthcare recommends that a telephone or written request for service advice be made to the nearest GE Healthcare Regional Service Center. This Product or any of its parts should not be repaired other than in accordance with written instructions provided by GE Healthcare and by GE Healthcare trained personnel. The Product must not be altered without GE Healthcare's prior written approval. The user of this Product shall have the sole responsibility for any malfunction that results from improper use, faulty maintenance, improper repair, damage or alteration by anyone other than GE Healthcare..

Important

The information contained in this service manual pertains only to those models of products which are marketed by GE Healthcare as of the effective date of this manual or the latest revision thereof. This service manual was prepared for exclusive use by GE Healthcare service personnel in light of their training and experience as well as the availability to them of parts, proper tools and test equipment. Consequently, GE Healthcare provides this service manual to its customers purely as a business convenience and for the customer's general information only without warranty of the results with respect to any application of such information.

Furthermore, because of the wide variety of circumstances under which maintenance and repair activities may be performed and the unique nature of each individual's own experience, capacity, and qualifications, the fact that a customer has received such information from GE Healthcare does not imply in anyway that GE Healthcare deems said individual to be qualified to perform any such maintenance or repair service. Moreover, it should not be assumed that every acceptable test and safety procedure or method, precaution, tool, equipment or device is referred to within, or that abnormal or unusual circumstances, may not warrant or suggest different or additional procedures or requirements.

This manual is subject to periodic review, update and revision. Customers are cautioned to obtain and consult the latest revision before undertaking any service of the equipment.



CAUTION:

Servicing of this product in accordance with this service manual should never be undertaken in the absence of proper tools, test equipment and the most recent revision to this service manual which is clearly and thoroughly understood.

Technical Competence

The procedures described in this service manual should be performed by trained and authorized personnel only. Maintenance should only be undertaken by competent individuals who have a general knowledge of and experience with devices of this nature. No repairs should ever be undertaken or attempted by anyone not having such qualifications. Genuine replacement parts manufactured or sold by GE Healthcare must be used for all repairs. Read completely through each step in every procedure before starting the procedure; any exceptions may result in a failure to properly and safely complete the attempted procedure.

Warnings

**WARNING:**

Before using the OmniBed, read through this entire manual. As with all medical equipment, attempting to use this device without a thorough understanding of its operation may result in patient or user injury. This device should only be operated by personnel trained in its operation under the direction of qualified medical personnel familiar with the risks and benefits of this type of device. Additional precautions specific to certain procedures are found in the text of this manual.

**WARNING:**

Complete the Pre-use Checkout chapter of the Operation and Maintenance manual before putting the unit into operation. If the incubator fails any portion of the checkout procedure it must be removed from use and repaired.

**WARNING:**

Do not use the OmniBed in the presence of flammable anesthetics; an explosion hazard exists under these conditions.

**WARNING:**

Always disconnect the power before performing service or maintenance procedures detailed in this manual. Apply power only if you are specifically instructed to do so as part of the procedure.

**WARNING:**

Thoroughly air dry the incubator after cleaning it with flammable agents. Small amounts of flammable agents, such as ether, alcohol or similar cleaning solvents left in the incubator can cause a fire.

Cautions



CAUTION:

Only competent individuals trained in the repair of this equipment should attempt to service it as detailed in this manual.



CAUTION:

Detailed information for more extensive repairs is included in the service manual solely for the convenience of users having proper knowledge, tools and test equipment, and for service representatives trained by GE Healthcare.

**ПРЕДУПРЕЖДЕНИЕ**

Това упътване за работа е налично само на английски език.

- (BG)
- Ако доставчикът на услугата на клиента изиска друг език, задължение на клиента е да осигури превод.
 - Не използвайте оборудването, преди да сте се консултирали и разбрали упътването за работа.
 - Неспазването на това предупреждение може да доведе до нараняване на доставчика на услугата, оператора или пациента в резултат на токов удар, механична или друга опасност.

**警告**

本维修手册仅提供英文版本。

- (ZH-CN)
- 如果客户的维修服务人员需要非英文版本，则客户需自行提供翻译服务。
 - 未详细阅读和完全理解本维修手册之前，不得进行维修。
 - 忽略本警告可能对维修服务人员、操作人员或患者造成电击、机械伤害或其他形式的伤害。

**警告**

本服務手冊僅提供英文版本。

- (ZH-HK)
- 倘若客戶的服務供應商需要英文以外之服務手冊，客戶有責任提供翻譯服務。
 - 除非已參閱本服務手冊及明白其內容，否則切勿嘗試維修設備。
 - 不遵從本警告或會令服務供應商、網絡供應商或病人受到觸電、機械性或其他形式的危險。

**警告**

本維修手冊僅有英文版。

- (ZH-TW)
- 若客戶的維修廠商需要英文版以外的語言，應由客戶自行提供翻譯服務。
 - 請勿試圖維修本設備，除非您已查閱並瞭解本維修手冊。
 - 若未留意本警告，可能導致維修廠商、操作員或病患因觸電、機械或其他危險而受傷。

**UPOZORENJE**

Ovaj servisni priručnik dostupan je na engleskom jeziku.

- (HR)
- Ako davatelj usluge klijenta treba neki drugi jezik, klijent je dužan osigurati prijevod.
 - Ne pokušavajte servisirati opremu ako niste u potpunosti pročitali i razumjeli ovaj servisni priručnik.
 - Zanimarite li ovo upozorenje, može doći do ozljede davatelja usluge, operatera ili pacijenta uslijed strujnog udara, mehaničkih ili drugih rizika.

**VÝSTRAHA**

Tento provozní návod existuje pouze v anglickém jazyce.

- (CS)
- V případě, že externí služba zákazníkům potřebuje návod v jiném jazyce, je zajištění překladu do odpovídajícího jazyka úkolem zákazníka.
 - Nesnažte se o údržbu tohoto zařízení, aniž byste si přečetli tento provozní návod a pochopili jeho obsah.
 - V případě nedodržování této výstrahy může dojít k poranění pracovníka prodejního servisu, obslužného personálu nebo pacientů vlivem elektrického proudu, respektive vlivem mechanických či jiných rizik.



ADVARSEL

Denne servicemanual findes kun på engelsk.

- (DA)
- Hvis en kundes tekniker har brug for et andet sprog end engelsk, er det kundens ansvar at sørge for oversættelse.
 - Forsøg ikke at servicere udstyret uden at læse og forstå denne servicemanual.
 - Manglende overholdelse af denne advarsel kan medføre skade på grund af elektrisk stød, mekanisk eller anden fare for teknikeren, operatøren eller patienten.
-



WAARSCHUWING

Deze onderhoudshandleiding is enkel in het Engels verkrijgbaar.

- (NL)
- Als het onderhoudspersoneel een andere taal vereist, dan is de klant verantwoordelijk voor de vertaling ervan.
 - Probeer de apparatuur niet te onderhouden alvorens deze onderhoudshandleiding werd geraadpleegd en begrepen is.
 - Indien deze waarschuwing niet wordt opgevolgd, zou het onderhoudspersoneel, de operator of een patiënt gewond kunnen raken als gevolg van een elektrische schok, mechanische of andere gevaren.
-



WARNING:

This service manual is available in English only.

- (EN)
- If a customer's service provider requires a language other than English, it is the customer's responsibility to provide translation services.
 - Do not attempt to service the equipment unless this service manual has been consulted and is understood.
 - Failure to heed this warning may result in injury to the service provider, operator, or patient from electric shock, mechanical hazards, or other hazards.
-



HOIATUS

See teenindusjuhend on saadaval ainult inglise keeles

- (ET)
- Kui klienditeeninduse osutaja nõuab juhendit inglise keelest erinevas keeles, vastutab klient tõlketeenuse osutamise eest.
 - Ärge üritage seadmeid teenindada enne eelnevalt käesoleva teenindusjuhendiga tutvumist ja sellest aru saamist.
 - Käesoleva hoiatuse eiramine võib põhjustada teenuseosutaja, operaatori või patsiendi vigastamist elektrilöögi, mehaanilise või muu ohu tagajärjel.
-



VAROITUS

Tämä huolto-ohje on saatavilla vain englanniksi.

- (FI)
- Jos asiakkaan huoltohenkilöstö vaatii muuta kuin englanninkielistä materiaalia, tarvittavan käännöksen hankkiminen on asiakkaan vastuulla.
 - Älä yritä korjata laitteistoa ennen kuin olet varmasti lukenut ja ymmärtänyt tämän huolto-ohjeen.
 - Mikäli tätä varoitusta ei noudateta, seurauksena voi olla huoltohenkilöstön, laitteiston käyttäjän tai potilaan vahingoittuminen sähköiskun, mekaanisen vian tai muun vaaratilanteen vuoksi.
-

**ATTENTION**

Ce manuel d'installation et de maintenance est disponible uniquement en anglais.

- (FR)
- Si le technicien d'un client a besoin de ce manuel dans une langue autre que l'anglais, il incombe au client de le faire traduire.
 - Ne pas tenter d'intervenir sur les équipements tant que ce manuel d'installation et de maintenance n'a pas été consulté et compris.
 - Le non-respect de cet avertissement peut entraîner chez le technicien, l'opérateur ou le patient des blessures dues à des dangers électriques, mécaniques ou autres.

**WARNUNG**

Diese Serviceanleitung existiert nur in englischer Sprache.

- (DE)
- Falls ein fremder Kundendienst eine andere Sprache benötigt, ist es Aufgabe des Kunden für eine entsprechende Übersetzung zu sorgen.
 - Versuchen Sie nicht diese Anlage zu warten, ohne diese Serviceanleitung gelesen und verstanden zu haben.
 - Wird diese Warnung nicht beachtet, so kann es zu Verletzungen des Kundendiensttechnikers, des Bedieners oder des Patienten durch Stromschläge, mechanische oder sonstige Gefahren kommen.

**ΠΡΟΕΙΔΟΠΟΙΗΣΗ**

Το παρόν εγχειρίδιο σέρβις διατίθεται μόνο στα αγγλικά.

- (EL)
- Εάν ο τεχνικός σέρβις ενός πελάτη απαιτεί το παρόν εγχειρίδιο σε γλώσσα εκτός των αγγλικών, αποτελεί ευθύνη του πελάτη να παρέχει τις υπηρεσίες μετάφρασης.
 - Μην επιχειρήσετε την εκτέλεση εργασιών σέρβις στον εξοπλισμό αν δεν έχετε συμβουλευτεί και κατανοήσει το παρόν εγχειρίδιο σέρβις.
 - Αν δεν προσέξετε την προειδοποίηση αυτή, ενδέχεται να προκληθεί τραυματισμός στον τεχνικό σέρβις, στο χειριστή ή στον ασθενή από ηλεκτροπληξία, μηχανικούς ή άλλους κινδύνους.

**FIGYELMEZTETÉS**

Ezen karbantartási kézikönyv kizárólag angol nyelven érhető el.

- (HU)
- Ha a vevő szolgáltatója angoltól eltérő nyelvre tart igényt, akkor a vevő felelőssége a fordítás elkészítése.
 - Ne próbálja elkezdni használni a berendezést, amíg a karbantartási kézikönyvben leírtakat nem értelmezték.
 - Ezen figyelmeztetés figyelmen kívül hagyása a szolgáltató, működtető vagy a beteg áramütés, mechanikai vagy egyéb veszélyhelyzet miatti sérülését eredményezheti.



AÐVÖRUN

Þessi þjónustuhandbók er aðeins fánleg á ensku.

- (IS)
- Ef að þjónustuveitandi viðskiptamanns þarfnast annas tungumáls en ensku, er það skylda viðskiptamanns að skaffa tungumálaþjónustu.
 - Reynið ekki að afgreiða tækið nema að þessi þjónustuhandbók hefur verið skoðuð og skilin.
 - Brot á sinna þessari aðvörun getur leitt til meiðsla á þjónustuveitanda, stjórnanda eða sjúklings frá raflosti, vélrænu eða öðrum áhættum.
-



AVVERTENZA

Il presente manuale di manutenzione è disponibile soltanto in lingua inglese.

- (IT)
- Se un addetto alla manutenzione richiede il manuale in una lingua diversa, il cliente è tenuto a provvedere direttamente alla traduzione.
 - Procedere alla manutenzione dell'apparecchiatura solo dopo aver consultato il presente manuale ed averne compreso il contenuto.
 - Il mancato rispetto della presente avvertenza potrebbe causare lesioni all'addetto alla manutenzione, all'operatore o ai pazienti provocate da scosse elettriche, urti meccanici o altri rischi.
-



警告

このサービスマニュアルには英語版しかありません。

- (JA)
- サービスを担当される業者が英語以外の言語を要求される場合、翻訳作業はその業者の責任で行うものとさせていただきます。
 - このサービスマニュアルを熟読し理解せずに、装置のサービスを行わないでください。
 - この警告に従わない場合、サービスを担当される方、操作員あるいは患者さんが、感電や機械的又はその他の危険により負傷する可能性があります。
-



경고

본 서비스 매뉴얼은 영어로만 이용하실 수 있습니다.

- (KO)
- 고객의 서비스 제공자가 영어 이외의 언어를 요구할 경우, 번역 서비스를 제공하는 것은 고객의 책임입니다.
 - 본 서비스 매뉴얼을 참조하여 숙지하지 않은 이상 해당 장비를 수리하려고 시도하지 마십시오.
 - 본 경고 사항에 유의하지 않으면 전기 쇼크, 기계적 위험, 또는 기타 위험으로 인해 서비스 제공자, 사용자 또는 환자에게 부상을 입힐 수 있습니다.
-



BRĪDINĀJUMS

Šī apkopes rokasgrāmata ir pieejama tikai angļu valodā.

- (LV)
- Ja klienta apkopes sniedzējam nepieciešama informācija citā valodā, klienta pienākums ir nodrošināt tulkojumu.
 - Neveiciet aprīkojuma apkopi bez apkopes rokasgrāmatas izlasīšanas un saprašanas.
 - Šī brīdinājuma neievērošanas rezultātā var rasties elektriskās strāvas triecienu, mehānisku vai citu faktoru izraisītu traumu risks apkopes sniedzējam, operatoram vai pacientam.
-

**ĮSPĖJIMAS**

Šis eksploatavimo vadovas yra tik anglų kalba.

- (LT)
- Jei kliento paslaugų tiekėjas reikalauja vadovo kita kalba – ne anglų, suteikti vertimo paslaugas privalo klientas.
 - Nemėginkite atlikti įrangos techninės priežiūros, jei neperskaitėte ar nesupratote šio eksploatavimo vadovo.
 - Jei nepaisysite šio įspėjimo, galimi paslaugų tiekėjo, operatoriaus ar paciento sužalojimai dėl elektros šoko, mechaninių ar kitų pavojų.

**ADVARSEL**

Denne servicehåndboken finnes bare på engelsk.

- (NO)
- Hvis kundens serviceleverandør har bruk for et annet språk, er det kundens ansvar å sørge for oversettelse.
 - Ikke forsøk å reparere utstyret uten at denne servicehåndboken er lest og forstått.
 - Manglende hensyn til denne advarselen kan føre til at serviceleverandøren, operatøren eller pasienten skades på grunn av elektrisk støt, mekaniske eller andre farer.

**OSTRZEŻENIE**

Niniejszy podręcznik serwisowy dostępny jest jedynie w języku angielskim.

- (PL)
- Jeżeli serwisant klienta wymaga języka innego niż angielski, zapewnienie usługi tłumaczenia jest obowiązkiem klienta.
 - Nie próbować serwisować urządzenia bez zapoznania się z niniejszym podręcznikiem serwisowym i zrozumienia go.
 - Niezastosowanie się do tego ostrzeżenia może doprowadzić do obrażeń serwisanta, operatora lub pacjenta w wyniku porażenia prądem elektrycznym, zagrożenia mechanicznego bądź innego.

**AVISO**

Este manual de assistência técnica encontra-se disponível unicamente em inglês.

- (PT-BR)
- Se outro serviço de assistência técnica solicitar a tradução deste manual, caberá ao cliente fornecer os serviços de tradução.
 - Não tente reparar o equipamento sem ter consultado e compreendido este manual de assistência técnica.
 - A não observância deste aviso pode ocasionar ferimentos no técnico, operador ou paciente decorrentes de choques elétricos, mecânicos ou outros.

**ATENÇÃO**

Este manual de assistência técnica só se encontra disponível em inglês.

- (PT-PT)
- Se qualquer outro serviço de assistência técnica solicitar este manual noutra língua, é da responsabilidade do cliente fornecer os serviços de tradução.
 - Não tente reparar o equipamento sem ter consultado e compreendido este manual de assistência técnica.
 - O não cumprimento deste aviso pode colocar em perigo a segurança do técnico, do operador ou do paciente devido a choques eléctricos, mecânicos ou outros.



ATENȚIE

Acest manual de service este disponibil doar în limba engleză.

- (RO)
- Dacă un furnizor de servicii pentru clienți necesită o altă limbă decât cea engleză, este de datoria clientului să furnizeze o traducere.
 - Nu încercați să reparați echipamentul decât ulterior consultării și înțelegerii acestui manual de service.
 - Ignorarea acestui avertisment ar putea duce la rănirea depanatorului, operatorului sau pacientului în urma pericolelor de electrocutare, mecanice sau de altă natură.
-



ОСТОРОЖНО!

Данное руководство по техническому обслуживанию представлено только на английском языке.

- (RU)
- Если сервисному персоналу клиента необходимо руководство не на английском, а на каком-то другом языке, клиенту следует самостоятельно обеспечить перевод.
 - Перед техническим обслуживанием оборудования обязательно обратитесь к данному руководству и поймите изложенные в нем сведения.
 - Несоблюдение требований данного предупреждения может привести к тому, что специалист по техобслуживанию, оператор или пациент получит удар электрическим током, механическую травму или другое повреждение.
-



UPOZORENJE

Ovo servisno uputstvo je dostupno samo na engleskom jeziku.

- (SR)
- Ako klijentov serviser zahteva neki drugi jezik, klijent je dužan da obezbedi prevodilačke usluge.
 - Ne pokušavajte da opravite uređaj ako niste pročitali i razumeli ovo servisno uputstvo.
 - Zanemarivanje ovog upozorenja može dovesti do povređivanja servisera, rukovaoca ili pacijenta usled strujnog udara ili mehaničkih i drugih opasnosti.
-



UPOZORNENIE

Tento návod na obsluhu je k dispozícii len v angličtine.

- (SK)
- Ak zákazníkovi poskytovateľ služieb vyžaduje iný jazyk ako angličtinu, poskytnutie prekladateľských služieb je zodpovednosťou zákazníka.
 - Nepokúšajte sa o obsluhu zariadenia, kým si neprečítate návod na obsluhu a neporozumiete mu.
 - Zanedbanie tohto upozornenia môže spôsobiť zranenie poskytovateľa služieb, obsluhujúcej osoby alebo pacienta elektrickým prúdom, mechanické alebo iné ohrozenie.
-



ATENCIÓN

Este manual de servicio sólo existe en inglés.

- (ES)
- Si el encargado de mantenimiento de un cliente necesita un idioma que no sea el inglés, el cliente deberá encargarse de la traducción del manual.
 - No se deberá dar servicio técnico al equipo, sin haber consultado y comprendido este manual de servicio.
 - La no observancia del presente aviso puede dar lugar a que el proveedor de servicios, el operador o el paciente sufran lesiones provocadas por causas eléctricas, mecánicas o de otra naturaleza.
-

**VARNING**

Den här servicehandboken finns bara tillgänglig på engelska.

- (SV)
- Om en kunds servicetekniker har behov av ett annat språk än engelska, ansvarar kunden för att tillhandahålla översättningstjänster.
 - Försök inte utföra service på utrustningen om du inte har läst och förstår den här servicehandboken.
 - Om du inte tar hänsyn till den här varningen kan det resultera i skador på serviceteknikern, operatören eller patienten till följd av elektriska stötar, mekaniska faror eller andra faror.

**OPOZORILO**

Ta servisni priročnik je na voljo samo v angleškem jeziku.

- (SL)
- Če ponudnik storitve stranke potrebuje priročnik v drugem jeziku, mora stranka zagotoviti prevod.
 - Ne poskušajte servisirati opreme, če tega priročnika niste v celoti prebrali in razumeli.
 - Če tega opozorila ne upoštevate, se lahko zaradi električnega udara, mehanskih ali drugih nevarnosti poškoduje ponudnik storitev, operater ali bolnik.

**DİKKAT**

Bu servis kılavuzunun sadece ingilizcesi mevcuttur.

- (TR)
- Eğer müşteri teknisyeni bu kılavuzu ingilizce dışında bir başka lisandan talep ederse, bunu tercüme ettirmek müşteriye düşer.
 - Servis kılavuzunu okuyup anlamadan ekipmanlara müdahale etmeyiniz.
 - Bu uyarıya uyulmaması, elektrik, mekanik veya diğer tehlikelerden dolayı teknisyen, operatör veya hastanın yaralanmasına yol açabilir.
-

Chapter 1: Functional Description

This chapter provides a functional description for the Giraffe OmniBed, including sections representing each of the four boards. Refer to “Figure 1-1 Block Diagram” and section “6.5 Wiring Diagrams” when studying this chapter.

1.1 Control Board

The Intel 80C188EC microcontroller is an enhanced X86 processor with many on-board peripheral features, such as a interrupt controller, DMA controller, peripheral chip select driver, programmable timers, etc. The two programmable timers are used to control the two heaters (bed and radiant). The input to these timers is line frequency. This allows the control signal to be synchronized with the line frequency to better control the zero-crossing solid state relays. The on-board interrupt controller has several interrupts: analog-to-digital converter (ADC) conversion ready signal, overtemperature comparator output, watchdog output, power fail signal, and module interrupt signal from the system data bus. The microcontroller external bus is a multiplexed address and data bus.

The system memory consists of a programmable read-only memory (PROM) and static random access memory (SRAM). The EEPROM is used for calibration **and biomedical configuration values**. This memory holds the data even after power is turned off.

The RS-485 integrated circuit converts the RS-232 TTL signals from the microcontroller to RS-485 signals for the bus. This bus is the main communications bus from the control board to **the display board, scale, and servo oxygen board**.

There are two isolation transceivers used to isolate the circuits powered by +5V and the circuits powered by +5VSTBY (battery backup).

The board contains a 16 channel multiplexer. There are seven temperature measurement channels. These channels measure the two patient probes and the compartment probe (with two thermistors each), and the heat sink sensor used to measure the heat sink temperature. Additional channels include the humidity sensor (RHIN), LINE COMP & LINE COMP2, 5 Volts, Motor current, Vthref, VDAC, and 1.2Vind.

Attached to the **compartment** probe connection is the relative humidity signal conditioning circuitry. The 1V reference that is used for the analog circuitry is also the maximum input voltage and the offset voltage for the ADC. This yields a purely ratiometric system.

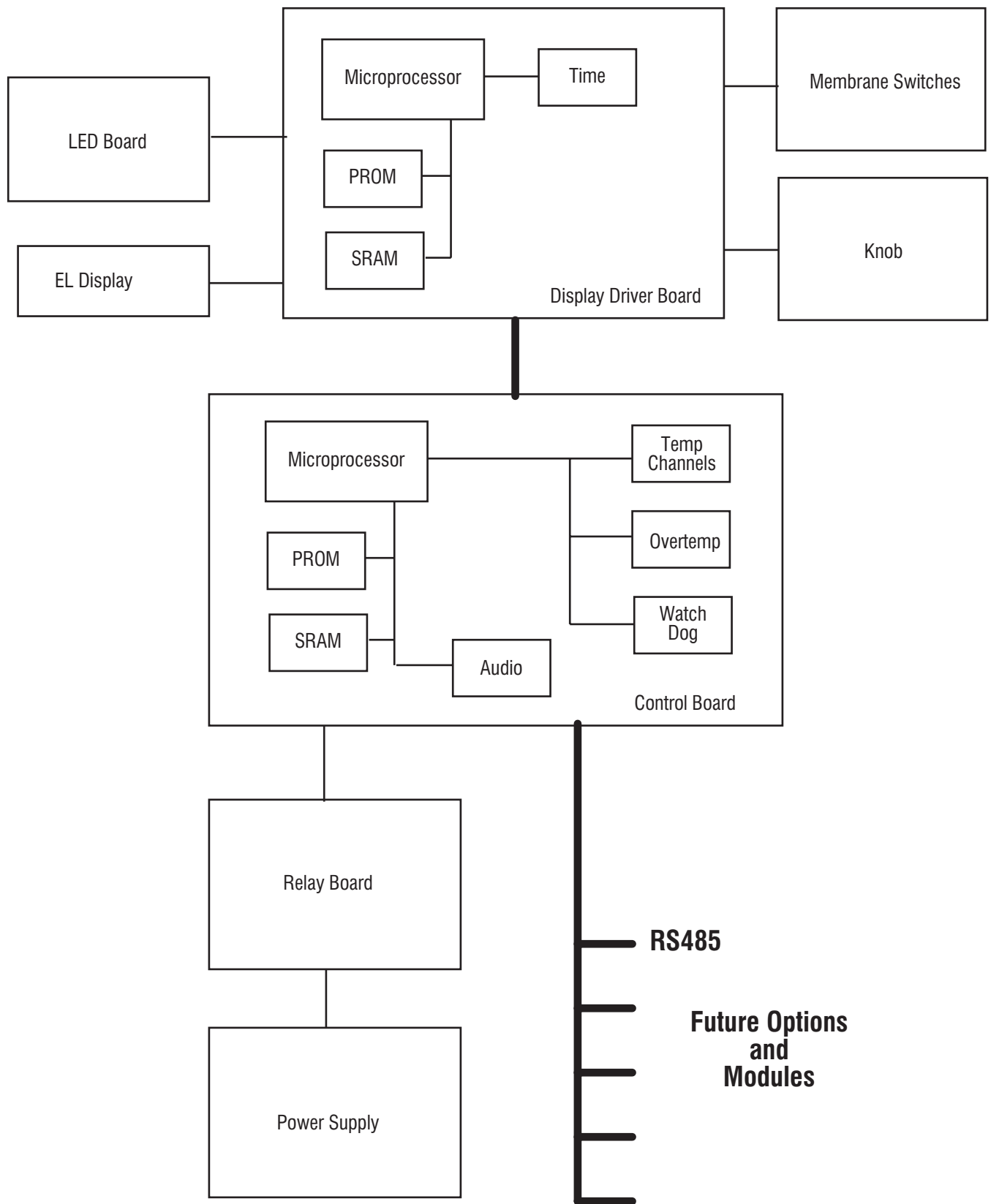

Figure 1-1 Block Diagram

The overtemperature circuit compares the air temperature to a reference level, generates an interrupt, and turns off the heat if the air temperature is higher than the reference level. The overtemperature circuit requires varying its voltage levels to accommodate various thermistor measurements. This is because the calibration is digital (no potentiometer).

The watchdog circuitry monitors the 80C188 microprocessor, and monitors the +5V and +5VSTBY voltages. It generates the interrupt signal and power failure signal to the 80C188 microprocessors. The audio circuit includes a 8752 microcontroller that reads a wavetable located in a PROM and sends the table to a digital audio circuit and amplifier. The high priority (HP) and other alarm signal lines select an output at the correct frequencies.

Three OR gates are combined to generate the error signal. The inputs to the circuit are overtemperature, power failure, and system failure. This circuit generates an error signal that turns off the heater and sounds the HP alarm. This circuit is independent of the microcontroller.

1.2 Relay Board

The Relay Board includes 2 safety relays, which close to supply mains power to the heater and motor circuits. Safety relay 1 is wired in series with the primary coil of the isolation transformer for the incubator and radiant warmer heaters. Safety relay 2 closes the mains supply to the humidifier isolation transformer and the transformer for the e-base and canopy motors. Control signals for the two relays originate on the Control Board.

The Relay Board interfaces the DC control signals to the two chassis mounted solid-state relays (SSRs), which control the incubator and radiant warmer heaters individually. The control signals for the two heater SSRs originate on the Control Board.

The Relay Board includes a SSR for the humidifier. The SSR output is wired in series with the humidifier heater. The humidifier SSR control signal originates on the Control Board.

There is one current sense circuit for the incubator and radiant warmer heaters and an additional one for the humidifier heater. These circuits consist of a small signal transformer that produces a current proportional to the current through the heater circuits. The current is rectified and measured. The subsequent comparator then generates a digital level based on a specified current level. This results in a signal to the Control Board representing the state of the heater (on or off).

The two line compensation circuits consist of a signal transformer connected to the mains voltage. The secondary of this transformer feeds a full wave rectifier and capacitor. The resulting DC voltage is proportional to mains voltage, and it is measured on the Control Board.

The line frequency circuit consists of a full wave rectifier and a comparator. This circuit generates a digital pulse with frequency twice that of the line frequency (50 or 60 Hz). The output signal is provided to the Control Board.

The Relay Board provides the +5v standby power supply to the entire Giraffe system. A +5V regulator generates the +5V standby from the diode OR combination of the system +12V power supply or the backup battery. If there is no mains power, then +12v is not present, and the battery will generate the +5V standby. When +12V

is present, the battery is biased out of the circuit with the diode and is merely being trickle charged through a resistor. **The battery charges only when the unit is powered on.**

The motor driver circuit turns the DC motor coils in the incubator airflow fan motor on and off based on feedback from the hall effect position sensors. This integrated circuit can also vary the speed and brake the motor based on input signals from the Control Board.

The airflow sensor consists of an opto-coupler that outputs a clocking pulse proportional to the fan movement. The signal is AC coupled to eliminate offset voltages and drifts. The resulting pulse is half wave rectified and stored in a capacitor to yield a DC voltage proportional to the fan speed. If the fan stops or there is no fan, this DC voltage becomes zero. The output signal is provided to the Control Board to indicate proper airflow motor operation.

The canopy and elevating base motor control circuits consist of a series of three relays. The speed relay connects the 15 volt secondaries of the toroidal transformer in parallel (with 15 volt output) for lowering the canopy and in series (with 30 volt output) for raising the canopy and raising or lowering the elevating base. The direction relay reverses the polarity of the voltage output from the speed relay depending on the direction of travel. The E/H select relay switches the output voltage from the direction relay to the canopy or elevating base motor depending on the switch that is pressed.

To minimize arcing in the relay contacts, the EH Activate MOSFET is switched off while the relays are switched for the proper voltage, direction, and motor. Once the relays are set, the MOSFET is switched on and proper voltage is applied to the correct motor.

The motor current sense circuit consists of a small signal transformer that produces a current proportional to the motor current. The transformer output current is converted to a voltage and filtered. An output voltage indicative of the motor current amplitude is provided to the Control Board. A subsequent comparator then generates a digital level based on a specified current level. This results in a signal to the Control Board indicating whether or not the e-base motor is stalled.

The Relay Board interfaces the user and system status input switch signals to the Control Board. Switch signals include, e-base and canopy activation, canopy and heater door position, and humidifier reservoir and water level status.

1.3 Display Driver Board / EL Display

The Display Driver board contains the same Intel microcontroller as the Control board. The processor on the display board is used to control the EL display contents and monitor user inputs received from the membrane switch panel and rotary encoder knob.

There are two groups of digital inputs: membrane switch panel and rotary encoder knob. The membrane switches are pulled high; pressing the switch grounds the input. The encoder also has a switch, and two optically isolated lines that pulse out of phase with each other. The number of pulses represents the number of steps the knob rotates. The phase of the pulses represents the direction of the knob rotation.

The display board system memory consists of a programmable read-only memory (PROM) and static random access memory (SRAM).

The RS-485 integrated circuit converts the RS-232 TTL signals from the microcontroller to RS-485 signals for the bus.

The timekeeping RAM has a battery integrated into the chip so that the time and date run are kept current even with the power off. The battery has a minimum life of 10 years. Operator configuration values, patient information (trending), and the error log are stored in this RAM.

The graphics controller is an S-MOS VGA controller. The graphics controller interfaces the data from the video RAM to the EL display. The controller also synchronizes the display using a horizontal pulse (LP) and a vertical pulse for the whole display frame (YD). The controller handshakes with the 80C188 using the READY line to eliminate any lost data during display refreshes.

1.4 LED Board

The LED Board contains five display banks and two display drivers. One of the display drivers controls the patient temperature and air temperature display banks. The other driver controls the patient set temperature, air set temperature, warmer bar graph, and the mode and override indicators.

This allows the two large displays (patient and air temperature) to be multiplexed at a slower rate than the other LEDs. This results in brighter large displays. Each driver has a brightness potentiometer that is preset at the factory and should not be adjusted in the field.

1.5 Power Supply

The universal input switching power supply converts the line voltage to +5V DC and +12V DC. This supply can source up to 75 watts. The 5 volts powers the electronics and the 12 volts is used by the EL display and for future boards. Acceptable voltage ranges are 4.75V - 5.25V and 10.8V - 13.2V.

1.6 Peripheral Components

For the heater isolation transformer with relay board revision 9 or lower, the heater isolation transformer isolates the incubator and radiant heaters from the mains voltage. The primaries mains input voltage comes from the relay board and is switched by safety relay 1 and is also routed through the heater current sense circuit. The dual primaries are connected in parallel for 115 volt operation and in series for 230 volt operation. The isolated secondary output voltage is always 115 volts and goes directly to the solid state relays and the incubator and radiant heaters.

For the heater isolation transformer with relay board revision 10 or higher, the heater isolation transformer isolates the incubator and radiant heaters from the mains voltage. The primaries mains input voltage comes from the relay board and is switched by safety relay 1. The dual primaries are connected in parallel for 115 volt operation and in series for 230 volt operation. The isolated secondary output voltage is always 115 volts and is input to the relay board where it is used by the heater current sense circuit. It then outputs from the relay board to the solid state relays and the incubator and radiant heaters

The humidifier isolation transformer isolates the humidifier heater from the mains voltage. The primaries mains input comes from the relay board and is switched by safety relay 2. The dual primaries and secondaries are connected in parallel for 115 volt operation and in series for 230 volt operation. The isolated secondaries output voltage is equal to the mains input voltage..

The toroidal transformer is used to buck the mains voltage down to the range required for the elevating base and canopy motors. The primaries mains input comes from the relay board and is switched by safety relay 2. The dual primaries are connected in parallel for 115 volt operation and in series for 230 volt operation. The output voltage from each secondary is about 15 volts for both 115 and 230 volt operation and is input to the relay board motor control circuits.

The two identical solid state relays (SSR's) are used to switch the isolated 115 volts to the radiant and incubator heaters. The SSR's are mounted to the back wall of the electronics enclosure below the toroidal transformer. The upper right SSR controls the incubator heater and the lower left controls the radiant heater.

The 8.4 NiMH battery is connected to the relay board. It is used to power the +5 STBY during power fail. The battery charges only when the unit is powered on.

1.6.1 Rail and Heater Door Switches

There are seven switches used to determine the position of the canopy and the heater doors.

Two normally open switches on each heater door determine the position of the doors. Each switch is wired in series with the corresponding switch on the other door. One pair of switches closes only when the doors are fully open and the other pair closes only when the doors are fully closed.

There are 3 normally open switches in the right upright which are used to determine the position of the canopy. The top switch closes when the canopy reaches the upper position. The middle switch detects when the canopy is about half way down. The bottom switch closes when the lowest position is reached.

The unit will function as a warmer only if the two heater door open switches and the top rail switch are all closed.

The system will control as an incubator only if the bottom rail switch and the two heater door closed switches are all closed.

As the canopy lowers the system senses the closure of the middle rail switch, then looks at the heater door closed switches. If they are not closed, the canopy will stop at that position and the Heater Doors Not Closed alarm will activate. This insures that the canopy will not lower to the lowest position if the heater doors are not closed.

1.7 DataLink Option

The DataLink option allows direct output of serial data to various remote monitoring systems, such as a computer or commercial RS-232 monitor. The DataLink option board contains the electronic circuitry necessary

to provide a 2500 VRMS isolated serial interface to meet the logic levels specified by EIA RS-232D and CCITTV.28.

The MAX250 and MAX251 (U1 and U2), together with two 6N136 optocouplers and transformer TR1, form an isolated RS-232 transmitter and receiver. The MAX250 connects to the non-isolated or “logic” side of the interface, translating logic signals to and from the optocouplers, while the MAX251 resides on the isolated or “cable” side, translating data between the optocouplers and RS-232 line drivers and receivers. In addition to the optocoupler drivers and receivers, the MAX250 also contains isolation transformer drive circuitry which supplies power to the isolated side of the interface, and the MAX251.

The transmit signal is input to the MAX250 driver (U1 pin 4) whose output (U1 pin 3) drives optocoupler U4. The optocoupler output (U4 pin 6) is then fed into the MAX251 driver (U2 pin 3). The output of the MAX251 driver (U2 pin 12) is at the logic levels conforming to EIA RS-232D and CCITTV.28. Conversely, the receive signal enters the MAX251 driver (U2 pin 10) and is stepped down to CMOS/TTL levels at U2 pin 5. This logic level drives optoisolator input (U3 pin 3) whose output is fed into U1 pin 10. The output (U1 pin 9) signal is then available to the control printed circuit board.

A slide switch SW1 is used as a “self test” for the RS-232 interface. In the closed position, the J30-1 transmit signal is sent through the MAX250/MAX251 transmitter and back into the receiver portions. The signal can be read at J30-2 and verified to be correct. Any external cable connection must be removed for this self test to function. CR1 and CR2 provide transient protection for MAX251. In normal operation SW1 should be in the open (OFF) position.

The nurse call signal is input at J30-5 as a TTL logic level. In the “no alarm” state, this signal is a logic high, which turns on Darlington Q1, energizing relay K1. This results in contact closure between J31-1 and J31-2. In the “alarm” state, J30-5 is a logic low, which turns off Q1, de-energizes K1 and results in contact closure between J31-2 and J31-3. K1 provides 2500 VRMS isolation between the relay coil inputs and contact outputs.

1.8 Servo Controlled Oxygen Option

The Giraffe Servo Control Oxygen System consists of an oxygen sensing circuit, Servo Oxygen circuit board, and an oxygen delivery system.

The sensing circuit is located beneath the bed and consists of a pair of fuel cell oxygen sensors, a three-way solenoid calibration valve, and a calibration fan. In normal operation the calibration valve is closed and allows the Giraffe fan to circulate gas from the infant compartment across the sensors.

The unit must be calibrated at least every 24 hours when servo oxygen is in use. After 24 hours have elapsed the system prompts the user to perform calibration. Once the operator initiates calibration, the calibration valve opens and the calibration fan is turned on. This draws ambient air across the sensors until a stable reading is obtained. This 21% oxygen reference value is then used to calibrate the measuring algorithm. After calibration 100% oxygen is briefly delivered to the system to ensure there are no occlusions. When calibration is complete the unit will resume controlling oxygen based on the last set point.

The system must have two sensors present to operate. One sensor is always used for control and the other is used for a redundant check and display. The sensors generate a voltage of about 40 millivolts at 21% oxygen concentration and about 200 millivolts at 100% oxygen concentration. The voltage is directly proportional

to the concentration of oxygen. Humidity and temperature sensors located in the sensor plug are used for voltage compensation. A fan mounted to the sensor-housing door is activated when the temperature reaches 50 degrees C. This fan circulates air to keep the sensors below the maximum allowable operating temperature, about 55 degrees C.

The Servo O2 board is located in the Giraffe controller enclosure. The microcontroller and integrated EPROM on the board perform the following:

- Convert sensor output from analog to digital
- Activates oxygen alarm conditions.
- Two-way communications via 485 bus with the Giraffe control board.
- Controls the calibration valve to select calibration mode.
- Controls the two supply valves to maintain the desired oxygen set point.
- Opens the safety relay, which removes power to the three-way valve and the supply valves in case of a system failure.

The oxygen delivery system consists of two solenoid supply valves, and a regulator assembly. The preset regulator regulates the oxygen supply to 345 kPa (50 psi). Two supply valves, controlled by the Servo Oxygen board, control flow to the infant compartment. Both valves are opened until the measured level gets close to the desired set point then one valve is closed. One valve is then cycled on and off as needed to maintain the desired oxygen levels in the infant compartment. The valve selected is alternated so both valves cycle about the same number of times. There are 2 fuses between the Servo O2 board and the supply valves that prevent high current from the board entering the valve housing should a short occur in the supply valves. A safety valve that shuts off oxygen flow whenever the canopy is raised actuates mechanically by the movement of the canopy support rail. When the canopy is down the valve is open (canopy up/valve closed). The safety valve actuates independently of the solenoid type supply valves.

1.9 Humidifier

Refer to the following diagram. Water enters the insulating cylinder (1) through a small hole in bottom. Steam rises along the heater cartridge protective insert (2) and is channeled between the heater mount (3) and the ramp block (4) and out the steam port (5).

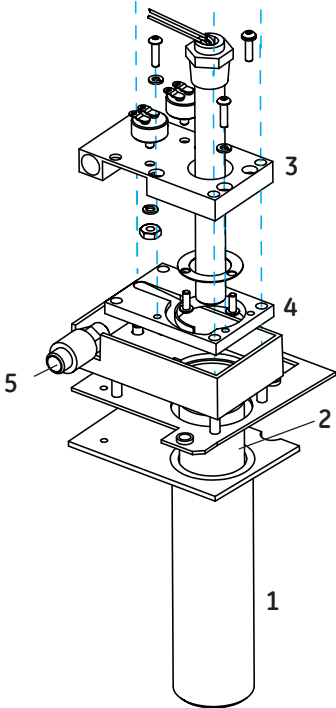

Figure 1-2 Humidifier

Chapter 2: Service Checkout

2.1 Setup

The OmniBed is shipped with the canopy in the locked down position. Before the canopy can be raised the rail shipping locks must be released. They are located in both sides of the OmniBed near the outside bottom of the uprights. An orange tear-away label marks their location. The lock consists of a socket head cap screw in a slot. Tightening the screw disengages the screw head from the slot and releases the lift rail. Using the 4 mm hex key provided with the unit, turn the screw clockwise about 8 rotations until the screw securely seats in its hole. Remove the tear away label.



WARNING:

Do not perform the preoperative checkout procedure while the patient occupies the unit.



WARNING:

Complete the preoperative checkout procedure section of this manual before putting the unit into operation. If the equipment fails any portion of the checkout procedure it must be removed from use and repaired.

2.2 Mechanical Checks

1. Disconnect the power cord for the mechanical portion of the preoperative checkout procedure.
2. Examine the power cord for any signs of damage. Replace the cord if damage is evident.
3. Check that both plug retaining brackets are in place.
4. Examine the unit overall for any damaged or missing parts.
5. Check that all the casters are in firm contact with the floor and that the unit is stable. Lock the caster brakes and check that they hold the unit in place. Release the brakes and check that the unit moves smoothly.
6. Check the operation of the two side doors. Open the doors and check that they swing all the way down and hang perpendicular to the bed. Check that the doors are securely attached to the unit and that the hinge pins are properly seated. Check that the inner walls are securely fastened to the doors. Close the doors and check that the latches hold the doors securely shut. The orange latch open indicators should not be visible when the latches are engaged. Check that the top of the doors meet the canopy seal.

7. Check the canopy seals:
 - a. If the unit has original canopy seals, which are attached with fasteners, check for visible cleanliness.
 - b. If the unit has enhanced canopy seals, which can be removed by hand, check the following:
 - Check for visible cleanliness.
 - Make sure that all seals (the two south corner covers, the two long side seals, the short south seal, and the notched north seal) can be easily removed and reinstalled. For details, refer to section 5.2.1, steps 10 and 15.
 - Make sure that none of the red indicators are visible after reinstallation.
8. Check the portholes. Open the portholes by pressing on the latch. The cover should swing open. Close the porthole and check that the latch holds the cover securely shut and that the cover seals tightly against the porthole gasket. Check that all the porthole seals are in place and are in good condition.
9. Check that the tubing access covers in the four bed corners and the large slot grommet at the head of the bed are in place and are in good condition.
10. Check the operation of the bed. The bed should rotate easily without binding. If the bed is properly seated and locked in place, the mattress should be level. With the bed rotated back into the straight position, check to see that the bed platform extends and stops when it is pulled out on either side. Check the operation of the bed tilt mechanism. Squeeze the tilt control and push down on the foot of the bed. The head of the bed should raise easily, and should stay in position at any angle along its tilt path when the tilt control is released. Push down on the head of the bed. The foot of the bed should raise easily, and should stay in position at any angle along its tilt path when the tilt control is released.

2.3 Controller Checks



WARNING:

Do not use the OmniBed in the presence of flammable anesthetics: an explosion hazard exists under these conditions.

1. Connect the OmniBed power cord to a properly rated outlet.
2. Connect the patient probe to jack 1 on the probe panel.
3. Switch on the power at the mains switch on the back of the unit, and at the standby switch on the jack panel, while holding in the override button (>37) on the control panel during power up until the software revision screen appears. Release the button and the first service screen will appear.
4. Scroll to “Down” and select it to bring up the second service screen. Select Status to see Status screen. Check status of the software self tests. These include: incubator heater on (INCHTRON), warmer heater on (WRMHTRON), incubator/warmer heater off (I/WHTR OFF), humidifier heater on (RHHTR), remote monitoring data stream (RS232LOOP), incubator fan on (FANON), and incubator fan off (FANOFF). All test should say PASS except RS232 LOOP (the connector pins must be shorted to get the PASS message).

5. Using the standby switch turn off the unit, then turn it back on. Verify the following:
 - All the displays and indicators light
 - The software revision appears
 - The prompt tone begins

NOTE: If the unit has been used in the last 2 hours, the patient history query appears.
6. Adjust the set temperature to silence the prompt tone.
7. Check the patient probe. If the probe is below 30 C, the display will show -L-. Warm it by placing it between your fingers, and verify that the baby temperature reading increases.
8. Unplug the patient probe and check that both visual and audio alarms trigger in the Baby control mode.
9. Check the canopy lift mechanism. Push the lift pedal and verify the canopy raises smoothly in one continuous movement to its upper limit, the heater doors open, and the unit shifts into warmer operation. Check that the pedals on both sides of the unit raise the canopy.
10. With the canopy raised, check the operation of the panel at the foot of the bed. Check that after you lift up on the panel, it swings down and hangs perpendicular to the bed. Check that the panel is securely attached. Check that it swings back up and seats in the closed position.
11. Lower the canopy and verify that it stops when you remove your finger from the hand switch. Check that it stops automatically at its lower limit, and that the canopy seal makes contact with all four bed sides, and that the unit shifts into the incubator operating mode. Check that the raise and lower buttons at the head of the bed on both sides of the unit raise and lower the canopy.
12. If so equipped, check the operation of the bed elevating system. Raise and lower the bed along its entire travel range, checking that the mechanism operates smoothly. Check that the pedals on both sides of the unit raise and lower the bed.
13. Check the power failure alarm and the battery backed up memory. Make note of the current control mode and temperature settings and wait one minute, then unplug the OmniBed from the wall outlet. An alarm should sound and the power failure indicator should light. Wait one to two minutes and plug the OmniBed back in. Verify that the alarm cancels and that the OmniBed returns to the same control mode and temperature settings it displayed before the power interruption.

NOTE: A fully charged battery should supply the power failure alarm for 10 minutes minimum (IEC 60601-2-19 clause 101.3). If the alarm is tested for the full 10 minutes, the OmniBed must be run at least two hours to recharge the battery before it is used with a patient. Total recharge time is 10 hours. The battery charges only when the unit is powered on.
14. Perform the Leakage Current and Ground Resistance checks in Chapter 3 of this manual.

2.4 Humidity Check

Turn on the Giraffe unit and verify that the Servo Humidity icon is on the screen. Set the Humidity to 65%. Wait for 4 minutes. If no alarms are seen (except for a possible “Add Water” message) the humidifier is operational.

NOTE: It is not necessary to have water in the reservoir to perform this test.

2.5 Servo Controlled Oxygen Check

2.5.1 Leak Check

This test checks for leaks between the O2 sensors and the Heat sink vent fitting.

1. Remove translation deck, tilt platform, upper pan, and fan.
2. Cover the heat sink vent near the fan shaft with adhesive tape. Make sure the tape will not interfere with fan rotation. Reinstall the fan, upper pan, tilt platform, and translation deck.

NOTE: If the conical shaped rubber grommet was removed with the fan, when reinstalling fan be sure that **rubber grommet clicks into groove on fan shaft.**

3. Power up the unit, hold down the ‘Air curtain’ button and press the ‘Down’ button to force the Giraffe into low fan speed.
4. Set O2 set point to 21%; the display will show the actual concentration in the larger numerals next to the set point. Open the doors until the actual concentration reaches 21% (ambient).
5. Run the Servo O2 calibration routine and wait for the calibration complete message. In approximately 20 seconds, the “Check O2 Supply” alarm should sound. If there is **no** alarm, the tubing between the sensor housing and the heat sink vent fitting has a leak or is disconnected. Repair the leak and repeat steps 1 through 4 of this procedure.
6. After performing the test, power off the unit. Remove the translation deck, tilt platform, upper pan, and the fan, and remove the adhesive tape. Be sure to remove any residue on the heat sink left by the tape.
7. Reassemble the system and run the calibration routine one final time.

2.5.2 Pre-use Checkout

This test checks for leaks between the chassis vent fitting and the O2 sensors.

1. Connect an acceptable hose from an oxygen supply to the oxygen inlet fitting on the unit. Supply pressure should be between 310 kPa (45 PSI) and 586 kPa (85PSI).
2. Power up the unit.

3. Set the Air Control set point to the desired temperature.
4. Wait for the air temperature to stabilize. This could take about 45 minutes, depending on your circumstances.
5. Hold down the 'Boost Air Curtain' button and press the 'Decrease Temperature' button to force the unit into low fan speed (Whisper Quiet Mode).
6. Wait 10 minutes to ensure stability of the Whisper Quiet Mode.
7. Select wrench icon on display screen to bring up setup menu. Select Cal Oxygen on the setup menu to initiate calibration.
8. When calibration is completed, 100% oxygen is delivered for approximately 20 seconds to ensure there are no occlusions in the system. Do not turn off the unit or disconnect the oxygen supply during this brief period after the 'Calibration Complete' screen appears. Exit calibration screen.
9. Select O2 icon on display screen to bring up Servo Control Oxygen menu. Set O2 set point to 65%.
10. Start timer and verify that unit reaches 60% in less than 10 minutes.

NOTE: If rise time is longer than 10 minutes check all tubing between the O2 sensors and the chassis vent fitting. The chassis vent may be identified by its mushroom cap shaped cover.

NOTE: Unit should not be placed in service unless the calibration is successful and the rise time test passes.

NOTE: The Low O2 alarm may activate during the rise time test. Silence the alarm and let the test continue.

NOTE: The "O2 Cal Lost – No O2" alarm may appear after the unit is turned on or returned from power fail condition. If this alarm appears, calibrate the oxygen sensors (using the wrench icon and the Cal Oxygen option) and resume use. If this alarm appears during normal operation, calibrate and continue use, but call service.

2.5.3 Supply Valve Leak Test

1. Connect oxygen supply to Servo Oxygen fitting.
2. Disconnect the 10mm hose from the expansion chamber.
3. Power up unit in Service Mode.
4. The canopy should be closed for this step and step 5. Scroll to Servo Oxygen service screen, and open V1 & V2 and verify that gas flows audibly .
5. Close V1 & V2 and place the 10mm hose in a cup of water. Verify that no more than 10 bubbles appear over a one minute period. If unit fails, replace supply valves.

6. Raise the canopy a couple of inches and open V1 & V2. Verify that no more than 10 bubbles appear over a one minute period. If unit fails replace two-way valve or spring assembly.

When test is completed, reattach 10 mm hose to expansion chamber.

2.6 Scale Check

The scale can be calibrated or checked using a Class F calibration weight between 1 kilogram and 8 kilograms (accuracy of 0.01%). (This class F Weight is available as part number 6600-0209-800.)

NOTE: For EU Member States:

- This scale has been designed and manufactured in accordance with the non-automatic weighing instruments (NAWI) directive, 90/384/EEC. In order to assure complete compliance to the Directive, have the unit calibrated by an accredited local test authority. If you are unable to identify a test authority, please contact your GE representative or distributor for assistance.
- Periodic re-verification (calibration) of the scale must be performed in accordance of the National Regulations Governing Legal Metrology. The required re-verification frequency will vary by country. Contact your local weights and measures authority for more information.

2.6.1 Mechanical Check

1. Examine the scale connector cord for damage.
2. Examine the LEMO connector to make sure it is tightly assembled.
3. Check for bent pins.
4. Examine the scale for obvious signs of damage.
5. If any of the parts are damaged replace them.

2.6.2 Weight Checks

IMPORTANT: If the scale fails the weight checks, calibrate it according to the procedure in Chapter 3 and then perform the weight checks again.

2.6.2.1 Center Weight Check

1. Enter the service screen by holding the override key (>37) while powering up. Set the scale resolution to 5 grams (if option is available).
2. Shut off the unit and power it back up to enter normal weighing mode.
3. Place a known weight in the center of the mattress and perform a weigh cycle. The displayed weight should be the known weight +/- 10 grams.

2.6.2.2 Off Center Weight Check

1. Enter the service screen by holding the override key (>37) while powering up. Set the scale resolution to 5 grams (if option is available).
2. Shut off the unit and power it back up to enter normal weighing mode.
3. Place a known test weight 10 cm (4") from the center of the mattress in 4 positions 90 degrees from each other (for example- toward each corner of the mattress) and check the reading at each position. Resulting weight readings should be within +/- 10 g of previously obtained center weight reading.

2.7 Other Accessory Checks

1. Check that all accessories are securely mounted and out of the path of the canopy.
2. Check the operation of any accessories with reference to their appropriate operation manuals.
3. Set up any required suction or gas supply systems. Check them for leaks as described in their respective operation manuals.

2.8 Cable Connections and Mechanical Controls

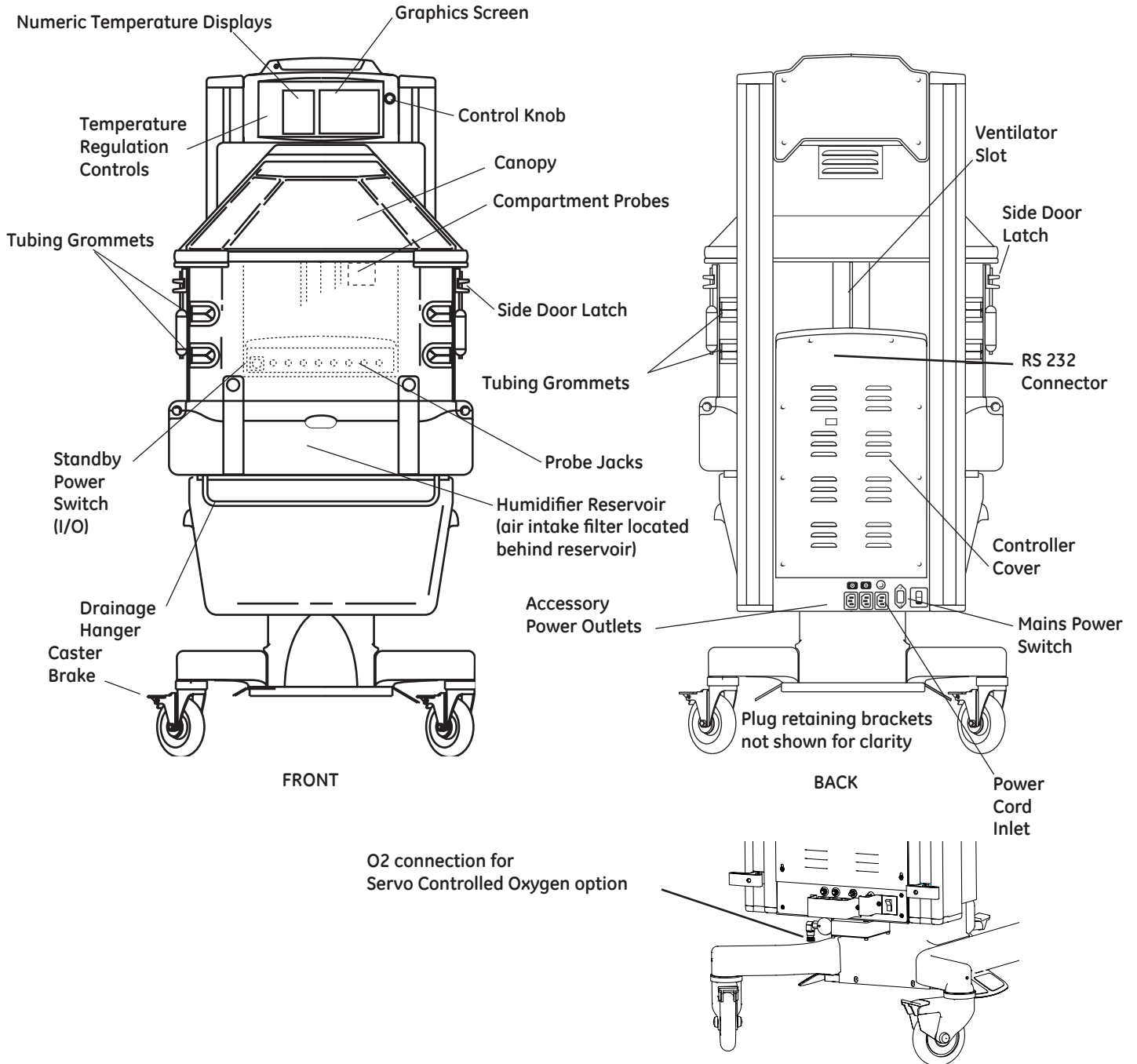
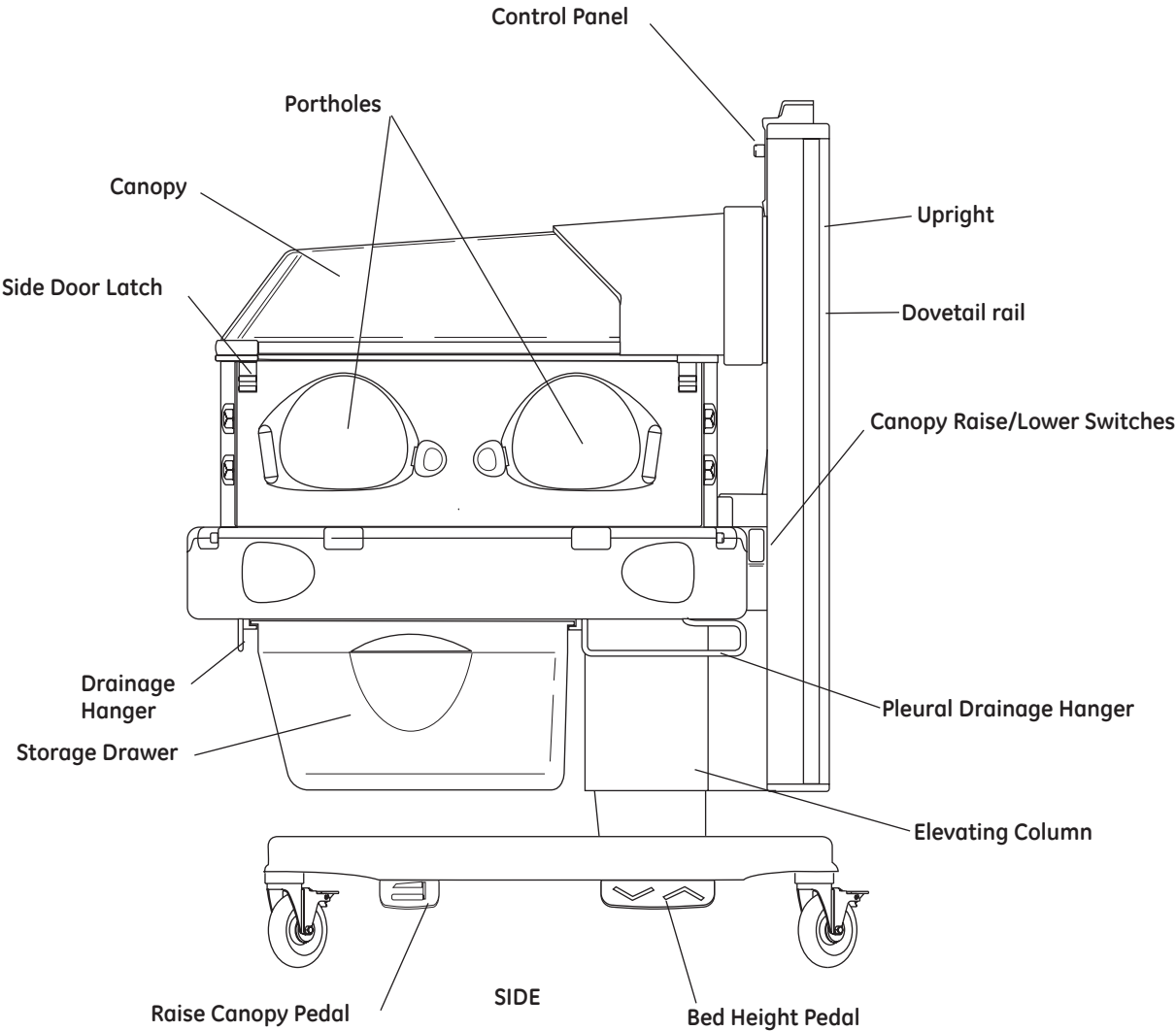

Figure 2-1 Connections and Controls



Chapter 3: Calibration and Maintenance



SENSITIVE TO ELECTROSTATIC DISCHARGE CAUTION

An Electrostatic Discharge (ESD) Susceptibility symbol is displayed to alert service personnel that the part(s) are sensitive to electrostatic discharge and that static control procedures must be used to prevent damage to the equipment.



WARNING:

After performing any repair or calibration, always perform the Service Checkout Procedure before putting the unit back into service.

3.1 Service Maintenance Schedule

The unit should be maintained in accordance with the procedures detailed in this manual. Service maintenance must be performed by a technically competent individual.

This schedule lists the minimum frequencies. Always follow hospital and local regulations for required frequencies.

Frequency	Maintenance
Annually	<ul style="list-style-type: none">Perform the electrical safety and calibration procedure as described later in this chapter.If the unit is equipped with a scale, perform checkout procedures in Chapter 2. If the scales fail the weight check, perform the scale calibration procedure in section 3.7.If the unit is equipped with Servo Controlled oxygen:<ul style="list-style-type: none">Replace vent screen.Perform supply valve leak test.Replace sensors*. It is recommended both sensors be replaced at the same time. <p>*Sensor life of one year is approximate. If the sensor is used often at high oxygen concentrations, sensor life will decrease.</p>
Every Two Years	<ul style="list-style-type: none">Replace the battery. <p>NOTE: The battery is used to sound the power failure alarm and to power memory circuits during a power failure. Run the unit for at least two hours to charge the new battery before using the unit. The battery charges only when the unit is powered on.</p>
Every Three Years	Calibrate the humidifier.

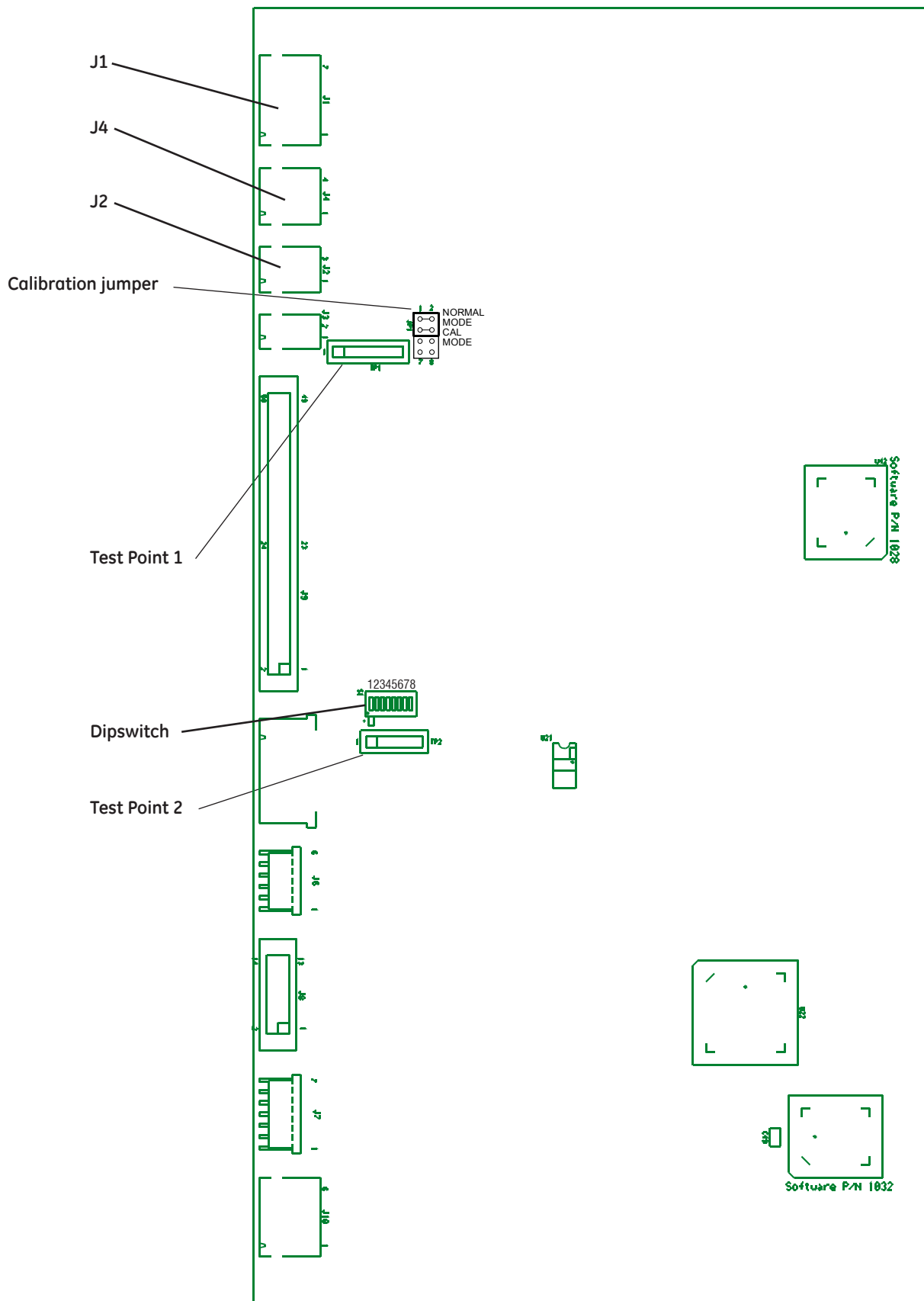

Figure 3-1 Control Board Test Points

3.2 Special Tools

The following tools (or their functional equivalents) are required to complete the recommended service procedures:

- Digital Multimeter, 4-1/2 digit
- Leakage Current Tester
- PLCC Extractor for removing socketed chips
- Static Control Work Station (recommended)
- Light gray touch-up paint (Munsell .16GY8.56-0.44 chroma)-18ml..... 6600-0714-200
- Servo Humidity Calibration Kit..... 6600-0048-850
- 5 kilogram (5000 gram) Class F test weight* 6600-0209-800

*The scale can be calibrated using a Class F calibration weight between 1 kilogram and 8 kilograms (accuracy of 0.01%).

NOTE: Do not use simulator 6600-0876-700 for validation testing.

3.3 System Calibration



NOTE: If only performing line voltage calibration, follow instructions in next section, 3.4.

IMPORTANT: Be sure to perform System Calibration after replacing a control board.

1. Turn power off.
2. Remove electrical enclosure back panel.
3. Unplug the temperature sensors and from J1, J4 and J2 on the control board.
4. Move jumper JP1 to the CAL MODE position on the control board (refer to “Figure 3-1 Control Board Test Points”). Be sure to orient the jumper correctly so pins 5-6 and 7-8 are shorted.
5. Turn power on. After running the power-up testing INITIALIZING will be displayed and dots will move across the top of the screen.
6. After about 90 seconds CALIBRATION MODE, Enter “VREF”, and Enter “Mains” will be displayed.
7. Using a 4 ½ digit DVM (capable of measuring to 0.1 millivolt) measure VREF at TP1, pins 1 and 6 (pin 6 is ground) on the control board. Measure to the nearest 0.1 millivolt. (Typical voltage reading will be 1.2350)
8. Dial in VREF using the control knob. Press the knob to enter the value.
9. Measure the Mains Voltage at the AC connectors at the bottom of the electronics enclosure cover.

10. Dial in the Mains voltage using the control knob. Press the knob to enter the value.
11. After a few seconds the dots will stop moving across the screen and DONE will appear on the top right of the display. Do not shut off the unit until the DONE message is displayed or the new calibration values will not be stored.

If the message "Mains voltage calibration failed. Please enter the mains voltage again" appears this indicates the dialed in line voltage is 20% different than the measured value (not the nominal value).

12. Power down the unit and move the calibrate jumper to the NORMAL MODE position. Be sure to orient the jumper correctly so pins 1-2 and 3-4 are shorted.

System and line voltage calibration are complete.

13. Proceed to humidifier calibration.

3.4 Line Voltage Calibration

IMPORTANT: Be sure to perform line voltage calibration after replacing a relay board.

1. Hold the override button (>37) while powering up the unit to enter the service screen.
2. On the second service screen select CAL LV.
3. Measure the line voltage at the AC connectors located at the bottom of the electrical enclosure.
4. On the CAL LV screen, dial in the mains voltage value that you measured and push the knob to enter it.
5. When calibration is completed, the screen will say Mains Voltage Calibration Complete.

If the message "Mains voltage calibration failed. Please enter the mains voltage again" appears this indicates the dialed in line voltage is 20% different than the measured value (not the nominal value).

3.5 Humidifier Calibration

IMPORTANT: Be sure to re-calibrate the humidifier whenever either the sensor or the control board is replaced.

IMPORTANT: In order for the water in the calibration bottle (6600-0048-850) to be completely saturated, most of the salt should not be dissolved. There should be as little standing water above the salt line as possible to minimize the response time. The salt in the calibration bottle may only be used for a period of one year after its initial mix with water then the kit should be discarded.

1. Take the cap off the humidity calibration bottle and add one half cap full of sterile distilled water to the bottle. Shake the bottle to thoroughly mix the salt and water solution. Place the smaller end of the elbow over the bottle.
2. Slide the elbow over the humidity sensor (mounted on the back wall) until it stops. This creates a 75% RH environment for the sensor.
3. Hold the override key while powering up to enter the service screen.
4. On the second service screen, select Cal RH. The screen will prompt "Push knob when RH reading is stable." Wait for 20 minutes or until the RH display stabilizes (does not change by more than 1% in 5 minutes).
5. Depress the control knob to complete the calibration. On software revision 1.3 and higher, you will have the option to select STABLE, SET TO DEFAULT or EXIT. STABLE initiates calibration. SET TO DEFAULT resets calibration values back to factory default settings. If you started calibration by mistake (without the calibration bottle in place, for example) you would select SET TO DEFAULT and then calibrate the unit. If you have entered the calibration routine by mistake, select EXIT to leave without initiating calibration.
6. If "RH Sensor Calibration Completed" is displayed, the calibration is complete. Depress the knob to exit the Cal RH routine.
7. If "RH Sensor Calibration Failed Try Again" is displayed, verify your setup and press the knob to try the calibration again. This message appears if the signal from the RH sensor is outside the values expected from the sensor at 65-85% RH. If the failure persists it means the readings are out of this range and either the calibration bottle or the RH sensor may be defective.

3.6 Servo Controlled Oxygen Calibration

1. Select Set Up icon (wrench) to bring up Set Up screen.
2. Scroll down and select Cal Oxygen to initiate calibration. Calibration is automatic and takes less than five minutes. A bar graph indicates progress toward completing calibration. If for any reason you wish to discontinue calibration before it is completed, turning the control knob in either direction will cause the word Cancel to appear on the calibration screen. Pushing in the control knob will discontinue calibration.

When calibration is completed, 100% oxygen is delivered for approximately 20 seconds to ensure there are no occlusions in the system. Do not turn off the unit or disconnect the oxygen supply during this brief period after the 'Calibration Complete' screen appears.

NOTE: The servo control oxygen system prompts for calibration every 24 hours, but the system may prompt for calibration if there is a large leak in the system (for example if a door is open) for half an hour.



CAUTION:

The servo-control system must be calibrated at the same atmospheric pressure in which it is to be used. Operation at atmospheric pressures other than that present during calibration may result in readings outside the stated accuracy for the unit.

3.7 Scale Calibration

NOTE: For EU Member States:

- This scale has been designed and manufactured in accordance with the non-automatic weighing instruments (NAWI) directive, 90/384/EEC. In order to assure complete compliance to the Directive, have the unit calibrated by an accredited local test authority. If you are unable to identify a test authority, please contact your GE representative or distributor for assistance.
- Periodic re-verification (calibration) of the scale must be performed in accordance of the National Regulations Governing Legal Metrology. The required re-verification frequency will vary by country. Contact your local weights and measures authority for more information.

NOTE: The scale is calibrated using a Class F calibration weight between 1 kilogram and 8 kilograms (accuracy of 0.01%).

1. Place the test weight on the center of the bed.
2. Hold the override key while powering up to enter the service screen.
3. On the second service screen, select Cal Scale.
4. Remove the weight and push the knob at the screen prompt "REMOVE THE WEIGHT AND PUSH KNOB". The screen will prompt "INITIALIZING" for a few seconds.

5. Replace the weight and push the knob at the screen prompt "PLACE TEST WEIGHT AND PUSH KNOB". The screen will prompt "MEASURING" for a few seconds.
6. When the screen prompts "ENTER TEST WEIGHT" Dial in the test weight to the nearest gram. Press the knob to enter. The screen will prompt "CALCULATING" for a few seconds.
7. When the screen prompts:

SAVE AND EXIT

EXIT ONLY

RESTORE DEFAULT

Select and enter "SAVE AND EXIT"
8. Turn off the power to exit the service mode.

3.8 Leakage Current

Use approved equipment and techniques to test the unit's leakage current and ground continuity. Follow the directions supplied by the test equipment manufacturer to verify the following:

1. Less than 300 microamperes measured at any exposed metal surface for equipment rated at 120 Vac, 50/60 Hz.
2. Less than 500 microamperes measured at any exposed metal surface for equipment rated at 220 Vac, 50/60 Hz or 240 Vac, 50/60 Hz.

3.9 Ground Resistance Check

Measure the resistance between the ground pin on the line cord plug and exposed metal of the electronic enclosure. The ground resistance must be less than 0.2 ohms.

Chapter 4: Troubleshooting

4.1 Startup Sequence

By default, the Giraffe OmniBed starts up in user mode. The next section describes how to start up the OmniBed in service mode. The following table describes the Giraffe OmniBed startup sequence for each mode:

User Mode	Service Mode
1. The alarm light turns on and remains on.	1. The alarm light turns on and remains on.
2. All LEDs and segments light up and the EL screen is yellow.	2. All LEDs and segments light up and the EL screen is yellow.
3. All LEDs turn off. The EL screen displays the Giraffe logo.	3. All LEDs turn off. The EL screen displays the Giraffe logo.
4. The alarm light turns off. Software revisions appear on the EL screen with OKs.	4. The alarm light turns off. Software revisions appear on the EL screen without OKs.
5. The user screen appears.	5. The service screen appears.

4.2 Service Screen

To access the service screen, hold in the override button (>37) during power up until the software revision screen appears. Release the button and the first service screen will appear.

DAC Volt	0.000	ADT	22.66
Language	English	ACT	22.65
Temp U	C	P11	327.67
Volume	Maximum	P12	327.67
Pat Alarm	1.0C	P21	327.67
Elevate	Enable	P22	327.67
Pat Ctrl	Both	HSP	18208
Pat Algo	Cascade		
Preheat	25%	LV1	117.4
Canopy	Enable	LV2	117.8
Scale U	gms	LF	60
Scale R	10g	MC	0.001
Comfort	Enable	LFS	1000
Set Time		RH	50
View Mods		5V	5.059
Down		VR	1.233
		DV	0.000
Last Cal: 1/1/00 Fri 3,800 9:54am			

Figure 4-1 First Service Screen

Default options that may be selected from this screen appear along the left side of the screen

DAC Volt	Digital/Analog Converter voltage. This is the over temperature voltage that is used by the system to verify the computer independent circuitry is working. To manually test this circuit enter voltages from 0 to .5 V. The DV value at the bottom right corner of the screen should match this value within 10mV.
Language	English is the default language that appears on the EL display, but you can select French, Spanish, etc., depending on what software is installed.
Temp U	Changes temperature displays to show "Fahrenheit", "Celsius" or "Celsius Only" so the Fahrenheit option is not present on the user Set-up screen (Celsius is factory set default).
Volume	Select one of four volume settings. 1 is minimum, 4 is maximum.
Pat Alarm	Set the default Hot Baby/Cold Baby alarm to activate when either 0.5°C or 1.0°C difference is read between a set temperature and the baby probe temperature.
Elevate	Disable or enable the bed up/down pedal switches. If the pedals are disabled on the service screen, they cannot be enabled on the user setup screen (wrench icon).
Pat Ctrl	Allows you to disable patient control.
Pat Algo	To be used for future software options.
Preheat	Select from 10 to 50% radiant heater power to preheat without alarms; 25% is the default. NOTE: Resetting maximum preheat level to above 25% will result in noncompliance to device standard IEC 60601-2-21
Canopy	Disable or enable the canopy pedal switches; hand switches will remain active. If the switches are disabled on the service screen, they cannot be enabled on the user setup screen (wrench icon).
Scale U	Select from "Grams", "Pounds" or "Grams Only" so that the pounds option is not present on the user Scale screen (grams is the factory default).

Scale R	Select from 2 scale resolution settings; 10 grams or 5 grams (10 grams is the factory default).
Comfort	Allows you to remove the Comfort Screen feature.
Set Time	Set real time clock for time, day and date. Choose how date is displayed (North American or European). Choose a 12 hour (AM/PM) or 24 hour time display.
View Mods	Display the current software revision of the options installed on this specific unit (Humidifier, Scale, SPO2, etc.)
Down	Go to second service screen.

Figure 4-2 Second Service Screen

Up	Return to previous screen.
Status	<p>Check status of all self test the software runs continuously. These include: incubator heater on (INCHTRON), warmer heater on (WRMHTRON), incubator/warmer heater off (I/WHTROFF), humidifier heater on (RHHTR), remote monitoring data stream (RS232LOOP), incubator fan on (FANON), and incubator fan off (FANOFF).</p> <p>If the RS232 option is not installed RS232LOOP will display N/A. To test the circuit if the option is installed, short pins 2 and 3 on the 9 pin connector on the back of the electrical enclosure.</p>
Switches	Select to bring up a diagnostic diagram of the unit that displays the status of all the switches. If the circle next to the switch is lit, the switch is closed; if it is not lit, the switch is open. Also, while the switch status screen is active, you can hold down the alarm silence button to light the alarm light, system failure light and all LED segments to test them.

Figure 4-3 Status Menu

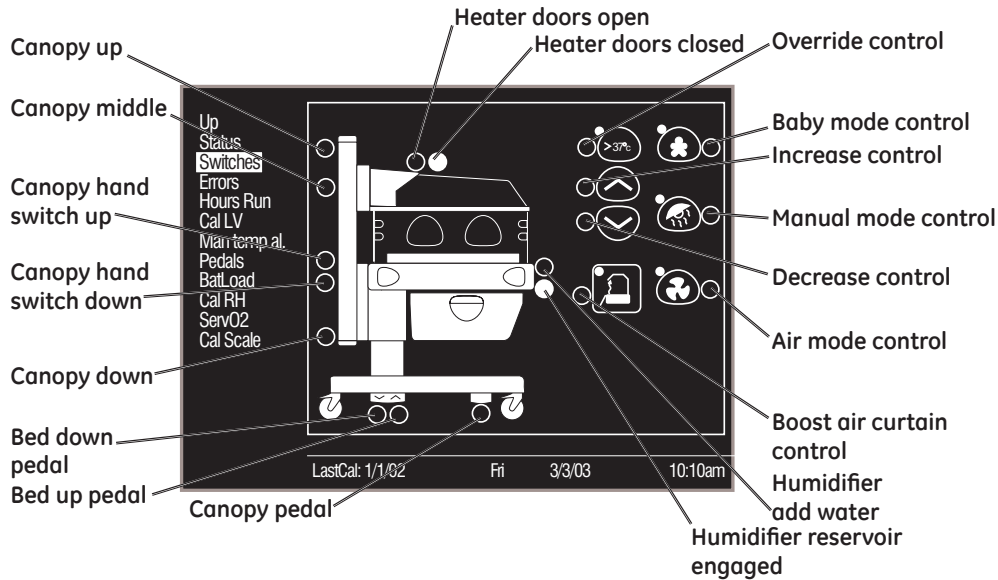

Figure 4-4 Switch Diagnostic Diagram

Errors	Lists a chronological log of the last 8 system errors that occurred. Shows error number and date. It is possible to clear the list.
Hours Run	Brings up a screen with 2 hour meters; one that is resetable and one that is not. To reset the resetable hour meter, highlight CLEAR and push the control knob. The non-resetable hour meter will roll to 0 at 199,999.
Cal LV	Use to calibrate line voltage at the factory. To calibrate line voltage follow the procedure in section 3.4.
Man temp al.	Use to enable or disable the patient temperature alarms in the manual mode (revision 1.40 and higher software only). If disabled on the service screen, it cannot be enabled on the user setup screen (wrench icon). The alarm will not activate if a patient set point has not been entered.

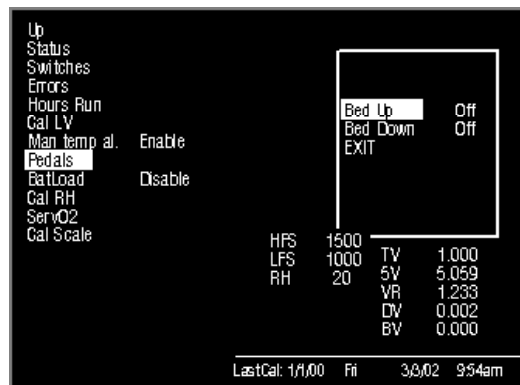

Figure 4-5 Pedal Screen

Pedals	In the event of a bed up/down or canopy pedal switch failure, selecting pedals allows the canopy to be raised or the bed to be raised or lowered (revision 1.6 software and higher).
BatLoad	Used for manufacturing only, not for service use.
Cal RH	Brings up humidifier calibration screen. Refer to "Chapter 3: Calibration and Maintenance" for information on how this screen is used.
Cal Scale	Brings up scale calibration screen. Refer to "Chapter 3: Calibration and Maintenance" for information on how this screen is used.

A number of diagnostic readings appear on the right side of the service screens.

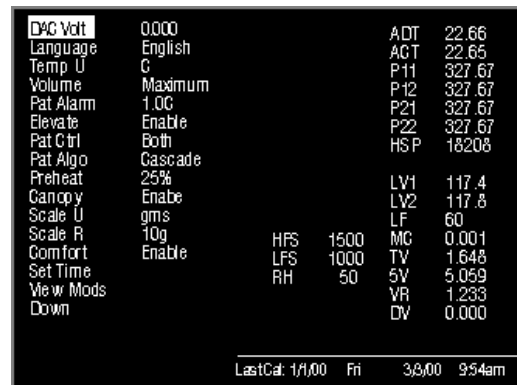

Figure 4-6 Service Screen

HFS	High fan speed. Should be 1500 +/- 100 (measured at power up only).
LFS	Low fan speed. Should be 1000 +/- 100 (measured at power up only).
RH	Relative Humidity. % humidity read in the patient chamber.
SR	Scale counts raw.
SC	Scale counts corrected. (1 count = 1 gram)
ADT	Air display temperature. Temperature read by the first thermistor in the compartment air probe. Should be + 0.3°C of ACT temperature.
ACT	Temperature read by second thermistor in the compartment air probe. Should be + 0.3°C of ADT temperature.
P11	Reading from the first thermistor in patient jack 1. Should be +/- 0.5°C of P12 temperature.
P12	Reading from the second thermistor in patient jack 1. Should be +/- 0.5°C of P11 temperature.
P21	Reading from the first thermistor in patient jack 2. Should be +/- 0.5°C of P22 temperature.
P22	Reading from the second thermistor in patient jack 2. Should be +/- 0.5°C of P21 temperature.
HSP	Heat sink sensor resistance. Should be 20000 ohms @ 25°C. Refer to the Tips section (4.6.8) for resistance verses temperature values.
LV1	Line voltage in first mains circuit. Should be +/- 4V of LV2.
LV2	Line voltage in second mains circuit. Should be +/- 4V of LV1.
LF	60Hz or 50Hz.
MC	Motor current. Shows current drawn by the canopy or e-base motor.
TV	Thermistor voltage. Voltage of thermistor circuits located on the mother board.
5V	Power supply voltage. Should be + 0.25V of 5V.
VR	Voltage reference. Independent voltage reference. Should be 1.235V + 1%.
DV	DAC output voltage. It should match the DAC volt value within 10 mV.
BV	Used for manufacturing only, not for service use.

Across the bottom of the screen the date of last time the temperature and line voltage calibration was performed appears plus the current time settings of the unit.

4.3 Alarm Messages

This section describes the alarm messages that may appear for the Giraffe OmniBed. The alarms have been organized in this section alphabetically.

4.3.1 "Air Probe Failure" Alarm

Cause or Circumstances	Failure	Action
The software detected a difference in the two air thermistors of > 0.5°C	Defective compartment air probe or harness	Measure the resistance of the two sensors at the harness from control board J1, Pins 1-2, and 3-4. Under stable conditions, the resistances should be within about 100 ohms. If defective, disassemble the air probe assembly and disconnect the 5 pin connector inside. Measure resistance of the two thermistors at pins 1-2 and 3-4 to determine if the sensor or harness is defective. Refer to the Tips section (4.6.7) for resistance values.
Defective control board.		If the thermistors and harness measure OK, replace the control board.

4.3.2 "Air Temp >38C" or "Air Temp >40C" Alarm

Cause or Circumstances	Failure	Action
Air Temp >38C or Air Temp >40C alarm activated even though compartment temp is < alarm temp. This alarm does not self reset after alarm condition is resolved.	None	Push the alarm silence button to clear the alarm.

4.3.3 "Baby Hot" or "Baby Cold" Alarm

Cause or Circumstances	Failure	Action
Baby Hot or Baby Cold alarm activated while unit is in Manual or Air mode. MANUAL TEMP alarm is set as active on the nurse setup screen or the service screen.	None	On service screen or nurse setup screen, select OFF for the MAN TEMP ALARM setting.

4.3.4 “Baby Mode Disabled” Alarm

Cause or Circumstances	Failure	Action
Baby mode has been disabled in the service screen and baby mode button is pressed.	None	Press alarm silence button to deactivate the alarm. If you wish to use the baby mode, re-enable it in service screen.

4.3.5 “Baby Probe 1 Failure” or “Baby Probe 2 Failure” Alarm

Cause or Circumstances	Failure	Action
Probe thermistors show difference > 0.5°C.	Defective patient probe	Replace patient skin probe.
	Defective patient probe jack wiring	Plug patient probe into probe jack 1. In service mode, note the difference between readings from P11 and P12. Plug the same probe into probe jack 2 and note the difference between readings from P21 and P22. If they are greater there is resistance in the probe jack harness. Replace the harness.

4.3.6 “Bad Membrane Switch” Alarm

Cause or Circumstances	Failure	Action
All	Defective membrane switch panel	Test switches in service mode. Replace membrane switch panel.

4.3.7 “Bed Heater Failure” Alarm

This alarm activates only when the canopy is at the bottom position.

Cause or Circumstances	Failure	Action
The software has turned on the incubator heater but it is either not turning on or the current sense circuit is not detecting that it is on.	The bed safety thermostat is open (possibly because the unit was shut down when the heater was hot).	If the unit was shut off when the heater was hot, allow the fan to run for several minutes to cool to below 40 degrees C then power down and back up. If the failure still persists, continue .
	Defective incubator heater, thermostat, or wire harness.	Check the resistance of the incubator heater. Refer to the Tips section (4.6.2). If defective, remove the chassis cover and measure resistance at thermostat and heaters to determine if heater, thermostat, or wire harness is defective.
	Defective incubator solid state relay (SSR).	In service mode, check the voltage across the control line of the incubator heater SSR. This control signal varies between 0 VDC and about 12 VDC. If voltage is present replace SSR. The two SSRs are identical and can be swapped for troubleshooting. If no voltage, continue.
	Defective 50 pin ribbon cable between the relay and control board.	Check for continuity on pins 36, 38, 39, and 40 (control signals). If defective, replace cable. If OK, continue.
	Defective relay board.	Replace the relay board.

4.3.8 “Bed Up/Down Pedal Failure” Alarm

Cause or Circumstances	Failure	Action
One of the bed up/down pedal switches is shorted.	Defective bed up/down pedal switch or harness.	Check the switches on the service screen to determine which switch is shorted or open. Refer to the Tips section (4.6.9). Raise the lower shroud and check continuity at the switch connectors to determine if a switch is defective or the wiring has a short.
Defective relay board.	Defective relay board.	If the alarm persists, replace the relay board.

4.3.9 “Bed Up/Down Pedal Switches Disabled” Alarm

Cause or Circumstances	Failure	Action
Bed up/down pedal switches have been disabled in nurse setup screen or service screen and pedal is pressed.	None	When pedal is released, the alarm deactivates. NOTE: If the bed up/down pedal switches are disabled in the service screen and you wish to use them, you can reactivate them only in the service screen.

4.3.10 “Canopy Pedal Disabled” Alarm

Cause or Circumstances	Failure	Action
Canopy pedal switches have been disabled in nurse setup screen or service screen and pedal is pressed.	None	When pedal is released, the alarm deactivates. NOTE: If the canopy pedal switches are disabled in the service screen and you wish to use them, you can reactivate them only in the service screen.

4.3.11 “Canopy Pedal Failure” Alarm

Cause or Circumstances	Failure	Action
One of the canopy pedal switches is shorted. (The alarm appears about 100 seconds after the short.)	Defective canopy pedal switch or harness.	Check the switches on the service screen to determine which is shorted. Refer to the Tips section (4.6.9). Raise the lower shroud and check continuity at the switch connectors to determine if a switch is defective or the wiring has a short.
One of the canopy hand switches is shorted.	Defective canopy hand switch or harness.	Replace one switch. If the error persists, replace the other switch.

4.3.12 “Canopy Pedal Pressed” Alarm

Cause or Circumstances	Failure	Action
The canopy pedal switch was pressed and held on during power up.	None	When the canopy pedal switch is released, the alarm deactivates. If alarm silence button is pressed or the pedal remains on for 100 seconds the Canopy Pedal Failure alarm activates and the canopy pedal switches are disabled. You can still raise and lower the canopy using the hand switches. Shut down the unit and power up to clear failure.
Other	Canopy pedal switch has failed	Refer to section 4.3.11 for troubleshooting information.

4.3.13 “Down Pedal Pressed” Alarm

Cause or Circumstances	Failure	Action
The bed down pedal switch was pressed and held on during power up.	None	When the bed down pedal switch is released, the alarm deactivates. If alarm silence button is pressed or the pedal remains on for 100 seconds the Bed Down Pedal Failure alarm activates and the bed down pedal switches are disabled. Shut down the unit and power up to clear failure.
Other	Bed down pedal switch has failed	Refer to section 4.3.8 for troubleshooting information.

4.3.14 "Fan Always in High Speed" Alarm

Cause or Circumstances	Failure	Action
Software cannot read temperature of the heat sink sensor in incubator heat sink.	Defective heat sink sensor or harness.	Check the heat sink temperature sensor resistance in service mode. You can also check heat sink sensor resistance by disconnecting the harness from J3 at the control board. Measure between pins 1 and 2. Refer to the Tips section (4.6.8). If defective, remove the chassis cover and disconnect the harness from heat sink sensor. Measure sensor resistance at pins 1-2 on the sensor harness to determine if sensor or harness is defective.
	Defective control board.	If the heat sink sensor and harness measure OK, then replace the control board.

4.3.15 "Fan Failure" Alarm

Cause or Circumstances	Failure	Action
Fan rotation is not being detected.	Optical fan sensor not detecting the fan	NOTE: System failure 25 and FAN FAILURE are both triggered by the optical fan sensor not detecting the fan. If this occurs at power-up, a system failure 25 will activate. If it occurs after the power tests are completed, the FAN FAILURE alarm will activate.
Fan is not turning.	Fan or fan hub not seated properly	Verify the fan hub is properly seated all the way down on the fan shaft. (It may be necessary to wet the part to get it to slide all the way down on to the shaft.) Verify the fan is seated in the groove at the top of the hub.
	Defective fan motor	Replace the fan motor.
	Defective relay board	Replace the relay board.
	Old design fan.	Replace with new design fan. The new fan can be identified by the grooves molded in the 2 black areas on the bottom of the fan (side facing the heat sink). The old fan has smooth surfaced black areas.
	Defective or obstructed optical sensor. Sensor holder or sensor gasket dirty or crazed.	Check that sensor, sensor holder, and gasket and free of dirt or other contaminants. Clean or replace.
	Defective 50 pin ribbon cable between the relay and control board.	Check for continuity on pin 9 (AIRFLOW). If defective, replace the cable. (Refer to the Tips section, 4.6.11.)
	Defective relay board.	If the problem persists, replace the relay board.

4.3.16 "Heater Doors Not Closed" Alarm

Cause or Circumstances	Failure	Action
This alarm activates as the canopy reaches about halfway down and the heater doors are not both closed.	Doors not closing.	Check to sure both heater doors are closing fully as the canopy starts to lower. If not, fix mechanical problem.
Doors are closed.	Defective switch or harness.	The two heater door switches are in series. Check for continuity at J31 1-3. If defective, remove heater housing cover and check continuity at connector in switch harness pins 1-3 to determine if switches or harness in rail is defective. If continuity is good, continue.
	Defective 50 pin ribbon cable between the relay and control board.	Check for continuity on pin 8. If defective, replace the cable. If good, continue.
	Defective relay board.	Replace the relay board.

4.3.17 "Heater Doors Not Opened" Alarm

Cause or Circumstances	Failure	Action
This alarm activates as the canopy reaches the top of its travel and the heater doors are not both open.	Doors not opening	Check to be sure both heater doors are opening fully when the canopy is all the way up. If not, fix mechanical problem. For example, adjust the spring tube position to allow full travel.
Doors are open	Defective switch or harness	The 2 door switches are in series. Check for continuity at J31 2-3. If defective, remove heater housing cover and check continuity at connector in switch harness pins 2-3 to determine if switches or harness in rail is defective. If continuity is good, continue.
	Defective 50 pin ribbon cable between the relay and control board.	Check for continuity on pin 7. If defective, replace the cable. If good, continue.
	Defective relay board	Replace the relay board.

4.3.18 "Humidifier Failure" Alarm



NOTE: The "Humidifier Failure" alarm can be caused by non-humidifier issues.

Cause or Circumstances	Failure	Action
The Motor Drive Failure alarm is on.	If this alarm activates, it opens safety relay 2 and disables the humidifier.	Refer to section 4.3.20 for troubleshooting.
The Elevating base does not function. If the elevating base does not function, then safety relay 2 is not being energized.	Defective 50 pin ribbon cable between the relay and control board.	Check for continuity on pin 34 (safety relay 2 control signal). If defective, replace the cable. If good, replace the relay board.
Elevating base functions	Humidifier safety thermostat is open.	Wait for the heater to cool. Cycle power to see if alarm resets.
	Defective humidifier heater or humidifier safety thermostat.	Check safety thermostat and humidifier heater resistance. Refer to the Tips section (4.6.6).
Humidifier heater measures OK	Relay boards rev 10 or higher	In service mode, verify mains voltage is present at the input to the humidifier isolation transformer. (J55 1-2)
	Relay boards rev 9 or lower. Humidifier Interface Board is mounted on relay board	In service mode, verify mains voltage is present at the input to the humidifier isolation transformer. (J56 1-2) J56 is on Humidifier Interface Board mounted on relay board.
No mains voltage at input to humidifier isolation transformer. (J55, 1-2)	Defective fuse. Relay boards rev 10 or higher	Check fuses F3 and F4 on the relay board. If OK, continue.
	Defective fuse. Relay boards rev 9 or lower. Humidifier Interface Board is mounted on relay board.	Check fuses on humidifier interface board.
	Defective relay board.	Replace the relay board.

4.3.19 “In Transition - Heat Off” Alarm

Cause or Circumstances	Failure	Action
As the canopy reaches the top position (for warmer mode) or the bottom position (for incubator mode), the software does not see the corresponding switch in the right rail close, to signal that the rail is at the end position.	NA	NOTE: This message should always be on when the unit is in transition between the incubator and warmer modes.
<p>WARMER MODE</p> <p>The In transition Heat Off message does not go off when canopy is all the way up.</p>	If the alarm message Heater Doors Not Open is also displayed, troubleshoot that alarm first.	
	Defective rail drive belt	Check the belt. Refer to the Tips section (4.6.10).
	Canopy is not going high enough because spring tube in right rail is not adjusted correctly.	Try pushing up slightly on the canopy to see if the switch closes and the message goes off. If it does, adjust the spring tube position so there is less spring tension. Refer to repair procedures, section 5.4.2 steps 14-15.
<p>INCUBATOR MODE</p> <p>In transition Heat Off message does not go off when canopy is all the way down.</p>	Defective switch or harness.	Switches can be tested in service mode. To check with an ohmmeter, disconnect harness from J36 on relay board. Measure resistance at pins 1-2. Should be open and then close when canopy reaches top of its travel. If not, either switch or harness are defective. Both are located in right rail.
	Canopy is not going low enough because it needs adjustment.	Adjust the canopy as described in Chapter 5.
	Defective switch or harness.	Switches can be tested in service mode. To check with an ohmmeter, disconnect harness from J36 on relay board. Measure resistance at pins 1-2. Should be open and then close when canopy reaches top of its travel. If not, either switch or harness are defective. Both are located in right rail.

4.3.20 “Motor Drive Failure” Alarm

Cause or Circumstances	Failure	Action
The software has detected that the elevating base motor or the canopy motor was running when not turned on.	Defective relay board.	<p>Replace the relay board.</p> <p>NOTE: Humidifier will not operate during this failure.</p>

4.3.21 Power Failure (LED Indicator)

Cause or Circumstances	Failure	Action
No AC power into unit	On/Off switch is not turned on.	Verify cord is plugged into a live wall outlet. Verify power switch/circuit breaker on back of unit is turned on.
Mains power is present but the 5V power supply is not present.	Defective fuse F1 or F2 on relay board.	Check the 5 volt supply. Refer to the Tips section (4.6.4). If no 5 volts, possible defective fuses on mains to the power supply, check F1 and F2 on relay board.
	Defective power supply.	Check input to power supply for mains voltage. If present and no 5 volts at output, then power supply is defective.

4.3.22 "Radiant Heater Failure" Alarm

This alarm activates only when the canopy is at the top position.

Cause or Circumstances	Failure	Action
The software has turned on the radiant heater but it is either not turning on or the current sense circuit is not detecting that it is on.	Defective radiant heater or wire harness.	Check the resistance of the radiant heater. Refer to the Tips section (4.6.3). If defective, remove heater housing cover and measure resistance at 3 pin connector on heater to determine if heater or wire harness is defective.
	Defective warmer solid state relay (SSR).	In service mode, check the voltage across the control line of the radiant heater SSR. This control signal varies between 0 VDC and about 12 VDC. If voltage is present, replace SSR. The two SSRs are identical and can be swapped for troubleshooting. If no voltage, continue.
	Defective 50 pin ribbon cable between the relay and control board.	Check for continuity on pins 37, 38, 39, and 40 (control signals). If defective, replace cable. If OK, continue.
	Defective relay board.	Replace the relay board.

4.3.23 "Temperature out of Calibration" Alarm

Cause or Circumstances	Failure	Action
Calibration data is lost.	Defective calibration.	Perform system calibration.
	Defective control board.	If problem persists replace the control board.

4.3.24 “Up Pedal Pressed” Alarm

Cause or Circumstances	Failure	Action
The bed up pedal switch was pressed and held on during power up.	None	When the bed up pedal switch is released, the alarm deactivates. If the alarm silence button is pressed or the pedal remains on for 100 seconds, the Bed Up Pedal Failure alarm activates and the Bed Up Pedal Switches are disabled. Shut down the unit and power up to clear failure.
Other	Bed up pedal switch has failed.	Refer to section 4.3.8 for troubleshooting information.

4.4 Error Codes

The following sections describe the meaning of each system failure code for the Giraffe OmniBed. Each table lists the possible causes and the corresponding recommended actions, in the order in which they should be tried.

For information on Giraffe Scale error codes, refer to the Giraffe Scale Service Manual, which can be ordered as part of a Giraffe OmniBed service manual kit: (US) 6600-0834-801 or (INTL) 6600-0834-802.

4.4.1 System Failure 0

System failure 0 indicates: Communication error between the display driver board and the control board.

Cause(s)	Action(s)
Defective scale.	Disconnect the scale connector at probe panel. Power cycle the unit. If the error clears, replace the scale.
Defective scale harness.	Disconnect the scale harness from J7 on the control board. (The scale may be plugged in.) Power cycle the unit. If the error clears, replace the scale harness.
Defective Servo Oxygen board.	Disconnect the RS485 harness from J8 on the Servo Oxygen board. Power cycle the unit. If the error clears, replace the Servo Oxygen Board.
Defective Servo Oxygen cable.	Disconnect RS485 bus cable from J6 on the control board. Power cycle the unit. If the error clears, replace the RS485 cable going to the Servo Oxygen board.
Defective battery.	The battery is used only for power failure. Try powering up the unit with the battery disconnected. If the error clears, replace the battery.
Defective 14 pin ribbon cable between control board and display driver board.	Check that the 14 pin ribbon cable is properly seated at J6 on the control board and at J20 on the display driver board. (Have all three parts on hand and try them one at a time. Try routing the cable around the outside of unit first, then try the display board, and then try the control board. If the error is intermittent, replace all three.)
Defective display driver board.	Replace display driver board.
Defective control board.	Replace control board.

4.4.2 System Failure 1

System failure 1 indicates: No Timer2.

Cause(s)	Action(s)
The Timer2 circuit of the microprocessor on the control board is defective.	Replace the control board.

4.4.3 System Failure 2

System failure 2 indicates: Timer2 too fast.

Cause(s)	Action(s)
Defective scale.	Disconnect scale connector at probe panel. Power cycle the unit. If the error clears, replace the scale.
Defective scale harness.	Disconnect scale harness from J7 on the control board. Power cycle the unit. If the error clears, replace the scale harness.
There is no line frequency signal to feed timer0 and timer1 of the microprocessor on the control board, or the timer2 of the microprocessor on the control board, is defective.	Power cycle the unit. If system failure 8 appears, refer to the instruction in this chapter for system failure 8 (section 4.4.8). If system failure 2 persists, replace the control board.

4.4.4 System Failure 3

System failure 3 indicates: During ADC calibration, the software detected a channel out of range.

Cause(s)	Action(s)
During system calibration, J1, J2, and J4 were not unplugged, or calibration jumper JP1 is not installed properly.	Before calibrating, make sure J1, J2, and J4 on the control board are disconnected. Verify JP1 is correctly positioned. (Refer to system calibration instructions.)
Defective circuit on control board.	Replace the control board.

4.4.5 System Failure 5

System failure 5 indicates: The volt reference is out of the 1.171V - 1.259V range.

Cause(s)	Action(s)
System calibration required.	Perform system calibration.
Defective control board.	Replace the control board.

4.4.6 System Failure 6

System failure 6 indicates: Defective overtemp DAC circuit on the control board.

Cause(s)	Action(s)
System calibration required.	Perform system calibration.
Defective control board.	Replace the control board.

4.4.7 System Failure 7

System failure 7 indicates: 1.0 V Thermistor reference voltage is out of 0.951V - 1.049V range.

Cause(s)	Action(s)
System calibration required.	Perform system calibration.
Defective control board.	Replace the control board.

4.4.8 System Failure 8

System failure 8 indicates: No Line Frequency. When troubleshooting this error code, have control board, 50 pin ribbon cable, and relay board on hand.

Cause(s)	Action(s)
Defective control board.	Measure the signal on the control board between J9 pin 43, and TP1-4 (Ground). It should be a 120 hertz signal. If the signal is OK, replace the control board.
Defective 50 pin ribbon cable between the relay board and control board.	If no signal, check continuity on the 50 pin cable, pin 43. If defective, replace the cable.
Defective relay board.	Replace the relay board.

4.4.9 System Failure 11

System failure 11 indicates: The ADC on the control board is not operating to spec (too slow).

Cause(s)	Action(s)
Defective humidifier sensor or cable	Disconnect J1 on the control board. If it powers up OK, either the cable or the humidity sensor is defective. Reconnect J1 and disconnect the 4 pin humidity sensor connector in the compartment probe. If the unit now powers up OK, the humidity sensor is defective. If not, the cable is defective.
Defective control board.	If the error persists with the replaced sensor or cable, replace the control board.

4.4.10 System Failure 12

System failure 12 indicates: Incorrect control board system software checksum.

Cause(s)	Action(s)
Defective system software PROM on control board.	Install new system software 6600-0234-850.
Defective control board.	If the error persists with new software, replace the control board

4.4.11 System Failure 13

System failure 13 indicates: Defective SRAM.

Cause(s)	Action(s)
Defective SRAM circuit on control board.	Replace control board

4.4.12 System Failure 14

System failure 14 indicates: Defective WDOG.

Cause(s)	Action(s)
Defective watch dog circuit on control board	Replace control board.

4.4.13 System Failure 15

System failure 15 indicates: Safety Relay 1 test failure. Unable to turn either heater on or off by switching safety relay 1. When troubleshooting this error code, have on hand at least the 50 pin ribbon cable.

NOTE: If system failure 22 appears during operation, system failure 15 should appear at startup.

Cause(s)	Action(s)
If this error occurs during system calibration, J1, J2, and J4 were not unplugged, or calibration jumper JP1 is not installed properly.	Before calibrating make sure J1, J2, and J4 on the control board are disconnected. Verify jumper JP1 is correctly positioned. (Refer to system calibration instructions.)
Air temperature sensor is above 40C at power-up.	If the unit was shut off when the incubator heater was hot, allow the fan to run for a few minutes to cool to below 40C, then power down and back up.
Defective sensor in compartment air probe.	Disconnect connector J1 from the control board. Power cycle the unit. If the error clears, either the compartment air probe or the air probe cable is defective. Reconnect J1 and disconnect the compartment air probe connector at the compartment probe. If the unit now powers up OK, the compartment air probe is defective.
Defective compartment air probe cable	If system failure 15 persists with connector J1 connected, and the compartment air probe disconnected, then the compartment air probe cable is defective.

Cause(s)	Action(s)
No output from heater isolation transformer. Defective relay board.	<p>In service mode, check the output voltage of the heater isolation transformer at the one pin connectors on the black and white wires on the transformer secondary. This secondary voltage should always read 115 volts.</p> <ul style="list-style-type: none"> • If 115 volts is present, then replace the relay board. • If 115 volts is not present, check that the mains voltage is input to the transformer primaries. • Be sure J49 on the relay board is properly connected. • Verify the configuration plug on the transformer primary is seated properly. <p>To measure primary input voltage on 115 volt units:</p> <ul style="list-style-type: none"> • Verify mains voltage is present at pins 2-5 (brown and orange wires) on the transformer primary configuration plug. • Verify mains voltage is present at pins 3-6 (yellow and blue wires) on the transformer primary configuration plug <p>To measure primary input voltage on 230 volt units:</p> <ul style="list-style-type: none"> • Verify mains voltage is present at pins 2-6 (brown and blue wires) on the transformer primary configuration plug. • If voltages are not present, verify mains voltage is present at pins 1-4 (black and red wires) on the transformer primary configuration plug. • If not, replace the relay board.
Defective heater isolation transformer	If voltage is present at primaries but no voltage output at secondaries, replace the heater isolation transformer.
Defective DAC circuit on control board.	If failure persists, replace control board. After replacing the control board, set it to incubator mode and restart the unit.
Defective solid state relay (SSR)	<p>Power up the unit in service mode. Run status test on the second service screen and verify that the I/WHTR OFF (incubator/warmer heater off) test fails. If the status test fails, then it is an SSR problem. If the status test does not fail, then try the recommended action for a defective current sense circuit on relay board, below.</p> <p>To determine which SSR is shorted, disconnect an output wire from them one at a time and rerun the status test.</p>
Defective radiant heater SSR	Disconnect the black wire (larger diameter) from the AC side of the radiant heater solid state relay. Run status test. If I/WHTR OFF test passes replace the radiant heater SSR. If it still fails reconnect the wire to the SSR.
Defective incubator heater SSR	Disconnect the black wire (larger diameter) from the AC side of the incubator heater solid state relay. Run status test. If I/WHTR OFF test passes replace the incubator heater SSR. If it still fails reconnect the wire to the SSR.
Defective current sense circuit on relay board.	Replace relay board.
Defective 50-pin ribbon cable	If failure persists, replace 50 pin ribbon cable.

4.4.14 System Failure 16

System failure 16 indicates: When the unit performed Power-on Self Test, either the incubator heater or the radiant heater could not be turned off.

Cause(s)	Action(s)
If this error occurs during System Calibration	Reconnect J1, J2 and J4 on the control board. Put JP1 in Normal position. (Refer to system calibration instructions). Power up unit in normal operating mode and follow instructions for the error that occurs.
Defective solid state relay (SSR)	Power up the unit in service mode. Run status test on the second service screen and verify that the I/WHTROFF test fails. If the status test fails, then it is an SSR problem. If the status test does not fail, then try the recommended action for a defective current sense circuit on relay board, below. To determine which SSR is defective, disconnect an output wire from them one at a time and rerun the status test.
Defective radiant heater SSR	Disconnect the black wire (larger diameter) from the AC side of the radiant heater solid state relay. Run status test. If I/WHTROFF test passes replace the radiant heater SSR. If it still fails reconnect the wire to the SSR.
Defective incubator heater SSR	Disconnect the black wire (larger diameter) from the AC side of the incubator heater solid state relay. Run status test. If I/WHTROFF test passes replace the incubator heater SSR. If it still fails reconnect the wire to the SSR.
Defective current sense circuit on relay board.	If failure persists, replace relay board.

4.4.15 System Failure 17

System failure 17 indicates: When performing Power-on Self Test in System Calibration mode, the radiant heater could not be turned off.

Cause(s)	Action(s)
	Reconnect J1, J2 and J4 on the control board. Put JP1 in Normal position. (Refer to system calibration instructions.) Power up unit in normal operating mode and follow instructions for the error that occurs.

4.4.16 System Failure 18

System failure 18 indicates: Defective Variables.

Cause(s)	Action(s)
Defective SRAM circuit on control board.	Replace the control board.

4.4.17 System Failure 19

System failure 19 indicates: No Audio Frequency.

Cause(s)	Action(s)
Defective battery	Battery is only used for power fail. Try powering up the unit with the battery disconnected. If the error clears, replace the battery.
Defective scale.	Disconnect scale connector at probe panel. Power cycle the unit. If the error clears, replace the scale.
Defective scale harness.	Disconnect scale harness from J7 on the control board. Power cycle the unit. If the error clears, replace the scale harness.
Defective Servo Oxygen board.	Disconnect the RS485 harness from J8 on the Servo Oxygen board. Power cycle the unit. If the error clears, replace the Servo Oxygen Board.
Defective Servo Oxygen cable.	Disconnect RS485 bus cable from J6 on the control board. Power cycle the unit. If the error clears, replace the RS485 cable going to the Servo Oxygen board.
Defective audio circuit on control board.	Replace socketed IC U22 on control board. If failure persists, replace the control board.
Defective control board	Replace the control board.

4.4.18 System Failure 20

System failure 20 indicates: Display WDOG Time Out.

Cause(s)	Action(s)
Display driver board software is not performing correctly.	Replace the display driver board.

4.4.19 System Failure 22

System failure 22 indicates: During operation, neither the radiant heater nor the incubator heater will turn ON.

Cause(s)	Action(s)
Refer to other errors.	Power down the unit. During the system tests after power-up the unit should detect system failure 15, or Radiant heater failure or bed heater failure. Follow the instructions in this manual for those failures.
Error reading distorted line signal.	Check the revision of the relay board. The revision code is located in a triangle printed on the component side of the PCB. Refer to relay board Figure 6-41 (revision 10 or higher) and Figure 6-42 (revision 9 or lower). If the relay board is revision 10 or lower, replace with revision 13 or higher relay board.
	If you have replaced the relay board with revision 13 or higher and you still have an intermittent problem, refer to the instructions in this manual for system failure 15 (section 4.4.13).

4.4.20 System Failure 23

System failure 23 indicates: During operation the system was unable to turn OFF either the radiant heater or the incubator heater.

Cause(s)	Action(s)
Other errors.	Power down the unit. During the system tests after power-up the unit should detect system failure 16. Follow the instructions in this manual for this failure.
Defective relay board.	If system failure 23 persists without system failure 16, replace the relay board.

4.4.21 System Failure 25

System failure 25 indicates: Fan rotation is not being detected.

NOTE: System failure 25 and FAN FAILURE are both triggered by the optical fan sensor not detecting the fan. If this occurs at power-up a system failure 25 will activate. If it occurs after the power tests are completed the FAN FAILURE alarm will activate.

Circumstance(s)	Cause(s)	Action(s)
Fan is not turning	Fan not connected.	Check jack.
	Fan or fan hub not seated properly.	Verify the fan hub is properly seated all the way down on the fan shaft and is seated in the groove at the top of the hub.
	Defective relay board.	Replace relay board.
	Defective fan motor.	Replace fan motor.
Fan is turning	Fan is turning too slow.	Check fan speed in service mode, should be about 1500 RPM in high fan speed. Note that this RPM measurement is only tested during the power up tests.
	Old design fan.	Replace with new design fan. The new fan can be identified by the grooves molded in the 2 black areas on the bottom of the fan (side facing the heat sink). The old fan has smooth surfaced black areas.
	Defective or obstructed optical sensor. Sensor holder or sensor gasket dirty or crazed.	Check that sensor, sensor holder, and gasket and free of dirt or other contaminants. Clean or replace.
	Defective 50 pin ribbon cable between the relay and control board.	Check for continuity on pin 9 (AIRFLOW). If defective replace cable.
	Defective relay board.	Replace relay board.

4.4.22 System Failure 26

System failure 26 indicates: During the power up tests, the system was unable to turn off safety relay 1.

Cause(s)	Action(s)
Defective relay board.	Replace the relay board.

4.4.23 System Failure 27

System failure 27 indicates: Defective non-volatile memory.

Cause(s)	Action(s)
Defective circuit on control board.	Replace the control board.

4.4.24 System Failure 28

System failure 28 indicates: During operation, the display driver board lost communication with control board.

Cause(s)	Action(s)
Refer to system failure 0.	Power down the unit, during the self-test the unit should detect system failure 0. Follow the instructions for system failure 0.
Defective flat ribbon cable between control board and display board.	If system failure 28 persists without system failure 0, replace the flat ribbon cable between control board and display board.

4.4.25 System Failure 29

System failure 29 indicates: Defective signal on control board.

Cause(s)	Action(s)
Defective control board	Replace the control board.

4.4.26 System Failure 30

System failure 30 indicates: Mains voltage reading LV1 is outside of the expected range.

Cause(s)	Action(s)
Mains Voltage Comp Circuit is not calibrated correctly.	Calibrate the line voltage.
High or low mains voltage. This failure is triggered if the mains voltage is outside the following ranges: <ul style="list-style-type: none"> • 100V: 80-115V • 115V: 95-132V • 230V: 195-270V 	Connect to proper mains voltage source
Defective 50 pin ribbon cable between the relay and control board.	Check for continuity on pin 48 and 49 (LineComp1,2) If defective replace cable.

Cause(s)	Action(s)
Defective relay board.	Measure the voltages at the relay board: <ul style="list-style-type: none"> • J37 pin 48-45 and J37 pin 49-45. • If mains voltage 100/115 = 3-5 volts, difference within 0.4 volts. • If mains voltage 230 = 7-10 volts, difference within 0.8. • If not, replace the relay board.
Defective control board.	If the voltages are OK replace the control board.

4.4.27 System Failure 33

System failure 33 indicates: Defective RH Solid State Relay.

Cause(s)	Action(s)
Defective RH Solid State Relay.	Replace relay board

4.4.28 System Failure 34

System failure 34 indicates: Software revision level does not match.

Cause(s)	Action(s)
The software revision of the control board and the display board are not compatible	This error may occur after replacing the control/display board. Be sure to install the software provided in the control/display board. Replace the System Software.

4.4.29 System Failure 35

System failure 35 indicates: Wrong dipswitch set up.

Cause(s)	Action(s)
Switches set wrong	Check the 8 position dipswitch on the control board. Verify that Switch 1 and Switch 2 are on.
Defective control board.	Replace control board.

4.4.30 System Failure 36

System failure 36 indicates: LV1 differs from LV2 by >10% of LV2.

Cause(s)	Action(s)
Mains Voltage Comp Circuit is not calibrated correctly.	Calibrate the line voltage.
Defective 50 pin ribbon cable between the relay and control board.	Check for continuity on pin 48 and 49 (LineComp1,2) If defective replace cable.

Cause(s)	Action(s)
Defective relay board.	Measure the voltages at the relay board: <ul style="list-style-type: none"> • J37 pin 48-45 and J37 pin 49-45. • If mains voltage 100/115 = 3-5 volts, difference within 0.4 volts. • If mains voltage 230 = 7-10 volts, difference within 0.8. • If not, replace the relay board.
Defective control board.	If the voltages are OK, replace the control board.

4.4.31 System Failure 37

System failure 37 indicates: Defective Switches (software 1.60 or higher).

Cause(s)	Action(s)
Both canopy up and canopy down position switches are closed.	Use the service screen to determine which switches are on. Use an ohmmeter to test the switches and cabling. Refer to the Tips section (4.6.5).

4.4.32 System Failure 38

System failure 38 indicates: Software has detected that door switches show that heater doors are both open and closed (which is not physically possible).

Cause(s)	Action(s)
Defective switches or harness	Use the SERVICE SCREEN to determine which switches are on. Use an ohmmeter to test the switches and cabling. Refer to the Tips section (4.6.5).

4.4.33 System Failure 50

System failure 50 indicates: Incorrect display driver board System Software checksum.

Cause(s)	Action(s)
Defective System Software PROM on display driver board.	Install new system software 6600-0234-850.
Defective display driver board.	If the system failure persists, replace display driver board.

4.4.34 System Failure 51

System failure 51 indicates: Display Defective SRAM.

Cause(s)	Action(s)
Defective SRAM circuit on the display driver board	Replace the display driver board.

4.4.35 System Failure 52

System failure 53 indicates: Display No Timer2.

Cause(s)	Action(s)
Defective display driver board.	Replace the display driver board.

4.4.36 System Failure 53

System failure 53 indicates: Display Timer2 Too Fast.

Cause(s)	Action(s)
Defective display driver board.	Replace the display driver board.

4.4.37 System Failure 55

System failure 55 indicates: Display board On Line Self Test Failure.

Cause(s)	Action(s)
Defective display driver board.	Replace the display driver board.

4.4.38 System Failure 60

System failure 60 indicates: Line Circuit Failure.

Cause(s)	Action(s)
Failure in relay board LV2 calibration circuitry during calibration.	Replace relay board.

4.4.39 System Failure 98

System failure 98 indicates: Overflow.

Cause(s)	Action(s)
Software on the control board is not performing correctly.	Replace the control board.

4.4.40 System Failure 99

System failure 99 indicates: Logic problem on the control board.

Cause(s)	Action(s)
Software on the control board is not performing correctly.	Replace the control board.

4.5 Troubleshooting Symptoms

Symptom	Possible Cause	Action
No audio alarm.	Defective speaker or harness.	Use an ohmmeter to verify the speaker resistance is about 8 ohms at relay board connector J40, pins 5-6. If defective, raise the lower shroud and measure at 6 pin connector to determine if speaker or harness is defective.
	Audio driver circuitry on control board is defective.	Replace the control board.
Unit equipped with servo-humidity but RH setpoint only shows 1-10.	Unit was powered on and the compartment probe was not plugged in at the probe panel (only on old style units with connector)	Cycle power after compartment probe is plugged in.
	Defective humidity sensor	Replace the humidity sensor.
	Defective control board.	If problem persists, replace control board.
ADD WATER message stays on even after water has been added.	Reservoir switch button is jammed (only on units with old style button).	Remove reservoir, but take care because surface may be hot! Check that the white reservoir switch button moves freely. If it is stuck in the closed position it should be replaced with the new style. (6600-1298-500)
	Defective reservoir switch.	Check resistance of reservoir switch at relay board harness J32, 2-3. Switch should be closed when reservoir is closed and open when reservoir is open.
	Defective 50 pin ribbon cable between the relay and control board.	Check for continuity on pin 6 (RHBOTTLE). If defective, replace cable.
	Defective relay board.	Replace relay board.
	Defective control board.	Replace control board.
Elevating base AND Canopy will not go up or down.	Pedal switches are disabled on nurse setup screen or service screen.	Try raising/lowering canopy using the hand switches. Check Setup screen (wrench symbol) or service screen to see if pedal switches are disabled.
	Defective toroidal transformer	Check the toroidal transformer. Refer to the Tips section (4.6.12). Replace transformer if defective.
	No mains input to the toroidal transformer.	Replace relay board.
	Output voltage from the toroidal transformer is OK. Defective fuse on relay board.	Check fuses F5, F6 on the relay board.
	Defective 50 pin ribbon cable between the relay and control board.	Check for continuity on pins 23, 24, 26, 27, 34 (motor control and safety relay 2 control signals). If defective, replace the cable.
	Output voltage from the toroidal transformer is OK. Fuses on relay board are OK. Defective relay board.	Replace relay board.

Symptom	Possible Cause	Action
Elevating base will not go up or down, canopy works OK.	Pedal switches are disabled on nurse setup screen or service screen.	Check Setup screen (wrench symbol) or service screen to see if pedal switches are disabled.
	Defective elevating base motor.	Check the voltage to the elevating base motor. Refer to the Tips section (4.6.9). If the voltage is OK, replace the elevating base assembly.
	Defective relay board.	Replace relay board.
Canopy will not go up or down with pedal switches or hand switches, Elevating base works OK.	Canopy motor turns. Defective belt or clutch.	Check rail drive belt and clutch. Refer to the Tips section (4.6.10).
	Canopy motor does not turn. Defective canopy motor	Check the voltage to the canopy motor. Refer to the Tips section (4.6.9). If voltage is OK, replace the canopy motor.
	Canopy motor does not turn. Defective 50 pin ribbon cable between the relay and control board.	Check for continuity on pins 23, 24, 26, 27, 34 (motor control and safety relay 2 control signals). If defective, replace the cable.
	Canopy motor does not turn. Defective relay board.	Replace relay board.
Canopy works in one direction but not the other.	Defective canopy motor.	Check the voltage to the canopy motor for both up and down movement. Refer to the Tips section (4.6.9). If OK, replace the canopy motor/gearbox.
	Defective 50 pin ribbon cable between the relay and control board.	Check for continuity on pins 23, 24, 26, 27 (motor control signals). If defective, replace the cable.
	Defective relay board.	Replace relay board.
Canopy travels down part way then stops or goes very slow for the last part.	An object fell into the opening behind the radiant heater floppy door.	Check that the floppy door, located behind the radiant heater moves freely. Look to be sure nothing has fallen behind the door.
Canopy rises slowly and stops before doors are opened fully.	Broken rungs in rail drive belt	Inspect belt. Refer to the Tips section (4.6.10).
Canopy is clouded.	Use of alcohol or hand-disinfectants	Replace canopy.
Unit will not switch to Baby Control Mode.	A patient probe is plugged into Jack 2 on the probe panel.	Disconnect probe from Jack 2 (unit will only allow Baby Control operation with a single probe in Jack 1).
	Baby Control is disabled on Service screen.	Select BOTH for Patient Control on service screen to activate Baby Control.

Symptom	Possible Cause	Action
Unit will not power up, alarm sounds.	Defective scale.	Disconnect scale connector at probe panel. Power cycle the unit. If error clears replace the scale.
	Defective scale harness.	Disconnect scale harness from J7 on the control board. Power cycle the unit. If error clears replace the scale harness.
	Defective Servo Oxygen board.	Disconnect the RS485 harness from J8 on the Servo Oxygen board. Power cycle the unit. If the error clears, replace the Servo Oxygen Board.
	Defective Servo Oxygen cable.	Disconnect RS485 bus cable from J6 on the control board. Power cycle the unit. If the error clears, replace the RS485 cable going to the Servo Oxygen board.
	Defective battery.	Remove the electrical enclosure cover and disconnect the battery. Power down and power up again. If the unit powers up, replace the 9V battery (66001024600).
	Defective power supply.	Check power supply voltages. Refer to the Tips section (4.6.4).
	Defective power harness to display board.	Verify power supply voltages at J23 on display driver board. <ul style="list-style-type: none"> • +5V 1-2 • +12V 1-3 • +5STBY 1-4
	Defective display driver board	Disconnect ribbon cable from J6 on control board. Power up unit. Giraffe logo should appear on display. After about 70 seconds the audible alarm sounds. If the logo does not appear replace the display driver board.
	Defective control board.	Replace control board.
Baby Hot or Baby Cold alarms activated while unit is in Manual Mode.	MANUAL TEMP alarm is selected on the Setup screen	Select OFF for MANUAL TEMP alarm on Setup screen.
Air Temp >38C or Air Temp >40C alarm activated even though compartment temp is < alarm.	Alarm is not designed to automatically reset after alarm condition is resolved.	Push the alarm silence button to clear the alarm.
Bed warms up very slowly, may not reach set temperature.	One of the bed heater cartridges is defective.	Feel the heat sink to see if one side is cooler than the other. Use care, since the heat sink can reach temperatures as great as 121C (250F). Replace the cartridge on the cool side.
Unit always powers up in service screen mode.	Defective dipswitch setting	Check position 8 on the control board dipswitch. Should be set to Off position.
	Override switch (>37C) on control panel shorted	Check switch on switch diagnostic screen.

Symptom	Possible Cause	Action
Screen refreshes every few seconds while scale is attached.	Defective circuit on control board (Unbiased RS485 bus during idle state).	Replace control board with revision 17 or higher.
	Defective scale.	Disconnect scale connector at probe panel. Power cycle the unit. If error clears replace the scale.
	Defective scale harness.	Disconnect scale harness from J7 on the control board. Power cycle the unit. If error clears replace the scale harness.
Noise from speaker on power down.	Microprocessor does not hold reset during power off.	If noise is excessive, replace control board with revision 17 or higher.
Fan is running in high speed but no FAN ALWAYS IN HIGH SPEED message and the Boost Air Curtain Indicator is not lit.	This is normal condition for 90 minutes after power up, 45 minutes after transition from open to closed bed mode, and during other conditions as determined by the heat control software.	To check HIGH and LOW fan speed, power up the unit. After the power up sequence is complete, hold down the Boost Air Curtain button and press the decrease temperature button to place the unit into low fan speed. The Boost Air Curtain button will now toggle the fan between high and low speeds.
Bed will not lock in tilt position.	Tilt ball not engaged in finger pocket latch.	Tilt the head of the bed platform all the way down while holding the latch open, then let the latch close to capture the tilt ball. (Refer to "Disassembly for complete cleaning" in the Operation and Maintenance manual.)
	Tilt brake pad failure.	Replace the tilt brake .
Baby Cold or Baby Hot Alarm does not trigger at 0.5°C or 1.0°C in Air Control mode.	Manual Temp. Alarm is disabled on Service Screen.	Enable Manual Temp. alarm.
Humidifier reservoir is crazed (has hairline cracks).	Sterilization	Replace humidifier reservoir.
Humidifier reservoir has scaling.	Use of tap water	Replace humidifier reservoir.

4.6 Additional Troubleshooting Tips

Following are tips on taking many of the measurements and diagnosing the failures that are referred to in the troubleshooting charts. For some tips it may be necessary to determine the revision level of the relay board. The revision code is located in a triangle printed on the component side of the PCB. Refer to relay board Figure 6-41 (revision 10 or higher) and Figure 6-42 (revision 9 or lower).

4.6.1 Raising and Lowering the Canopy or Elevating Base

In the event of an OmniBed system failure, it may be possible to raise or lower the canopy or the elevating base in the service mode. Hold down the override button (>37) to bring up the service screen. The pedals are now activated to assist in troubleshooting or transport. If the switches still do not operate it may be possible to raise the canopy and raise or lower the elevating base using the pedal function on page 2 of the service screen.

4.6.2 Incubator Heaters and Bed Safety Thermostat

There are two 115 volt incubator heaters rated at 225 watts at 104 volts and mounted at opposite ends of the incubator heat sink. They are always connected in parallel and are powered by isolated 115 volts from the heater isolation transformer. This voltage is switched by the incubator SSR.

The resistance of each heater is about 48 ohms and they are in parallel so you should measure about 24 ohms. Note that the bed safety thermostat is in series with the heaters so if the reading is open circuit you must take readings at the connectors under the bed to determine which is defective.

To measure the incubator heater resistance on units with revision 9 or lower relay boards, disconnect the black wire on the incubator SSR and the white wire on the output of the isolation transformer and measure between these 2 wires.

To measure the incubator heater resistance on units with revision 10 or higher relay boards, disconnect the black wire on the incubator SSR and the connector from J54 on the relay board. Measure between harness connector pin 4, and the black wire.

The incubator heater and bed safety thermostat resistance can also be measured by the removing the bottom cover and measuring directly at the components.

4.6.3 Radiant Heater

The 115 volt radiant heater is rated at 225 watts at 104 volts. It is powered by isolated 115 volts from the heater isolation transformer switched by the radiant warmer SSR.

The resistance of the radiant heater is about 24 ohms.

To measure the radiant heater resistance on units with revision 9 or lower relay boards disconnect the brown wire on the warmer SSR and the white wire on the output of the isolation transformer and measure between these 2 wires.

To measure the radiant heater resistance on units with revision 10 or higher relay boards disconnect the brown wire on the radiant heater SSR and the connector from J54 on the relay board. Measure between harness connector pin 3, and the brown wire.

The radiant heater resistance can also be measured by removing the heater housing and measuring on the radiant heater harness.

4.6.4 Power Supplies

The 5V and 12V supplies are generated on the power supply.

+5STBY is generated on the relay board. These voltages are distributed to the control board, display driver board, servo oxygen board, and expansion slots through a harness with a series of 4 pin connectors. The easiest place to measure the power supplies is at one of the spare 4 pin connectors on this power bus.

Signal	Location	Wire Color	Value
+5V	J42 pins 1-2	Orange and blue	4.75 to 5.25
+5VSTBY	J42 pins 1-4	Orange and green	4.75 to 5.25
+12V	J42 pins 1-3	Orange and red	10.8 To 13.2

The 5VSTBY should also be present during power fail.

+5VAN and -5VAN are generated on the control board and are only used on the control board. They can be measured on the test points on the control board.

Signal	Location	Value
+5V	TP2 pins 1-4	4.75 to 5.25
+5VSTBY	TP2 pins 3-4	4.75 to 5.25
+5AN	TP1 pins 5-6	4.75 To 5.25
-5AN	TP1 pins 4-6	-4.0 To -5.5

4.6.5 Switches/Thermostat

Use switch status diagram on the second service screen to assist in troubleshooting the switches.

Canopy up detect	Relay bd J36 pins 1-2	Closed when canopy is up
Canopy down detect	Relay bd J36 pins 7-8	Closed when canopy is down
Canopy middle	Relay bd J36 pins 4-5	Closed momentarily during transition
Heater doors open	Relay bd J31 pins 2-3	Closed when both heater doors are open
Heater doors closed	Relay bd J31 pins 1-3	Closed when both heater doors are closed
Humidity reservoir	Relay bd J32 pins 2-3	Closed when reservoir is closed
Add water thermostat	Relay bd J32 pins 1-3	Opens when reservoir needs water

Canopy foot control		
Left or Right	Relay bd J40 pins 3-4	Closed when either switch is pressed
E-base foot control		
Left or right up	Relay bd J40 pins 2-4	Closed when either switch is pressed
Left or right down	Relay bd J40 pins 1-4	Closed when either switch is pressed

The following switches are membrane switches. When closed the resistance should be less than 200 ohms.

Display touch panel switches		
Alarm Silence	Display Driver bd J21 pins 1-2	Closed when switch is pressed
>37 degrees	Display Driver bd J21 pins 1-3	Closed when switch is pressed
Servo Control	Display Driver bd J21 pins 1-4	Closed when switch is pressed
Up	Display Driver bd J21 pins 1-5	Closed when switch is pressed
Down	Display Driver bd J21 pins 1-6	Closed when switch is pressed
Manual Mode Rad. Htr	Display Driver bd J21 pins 1-7	Closed when switch is pressed

Intervention	Display Driver bd J21 pins 1-8	Closed when switch is pressed
Manual Mode Inc.	Display Driver bd J21 pins 1-9	Closed when switch is pressed
Canopy hand control		
Left up	Relay bd J35 pins 2-4	Closed when switch is pressed
Left down	Relay bd J35 pins 3-4	Closed when switch is pressed
Right up	Relay bd J35 pins 6-5	Closed when switch is pressed
Right down	Relay bd J35 pins 7-5	Closed when switch is pressed

4.6.6 Humidifier Heater/Safety Thermostat

The humidifier has two separate heater elements rated at 225 watts at 104 volts. They are connected in parallel for 115 volt operation and in series for 230 volt operation. The humidifier safety thermostat is in series with the heater. It opens at 130 +/-5 C and closes at 90 +/-8 C. Measure the resistance at J53.2 to J53.3.

The resistance of each heater is about 144 ohms so it should measure about 72 ohms for 115 units, 288 ohms for 230 units.

4.6.7 Compartment Air Probe and Patient Probes

Use the service screen to read the temperature of the compartment and patient probes.

There are two thermistors in each air probe or patient probe. During stable temperature conditions the thermistors should read the same resistance within a few ohms.

Patient probe #1	Control bd J4 pins 1-3, 2-3
Patient probe #2	Control bd J2 pins 1-3, 2-3
Compartment Air probe	Control bd J1 pins 1-2, 3-4

Temperature (C)	Resistance (Ohms)
20	12527
25	10000
30	8037
35	6500

4.6.8 Heat Sink Sensor Thermistor

Use the service screen to read the resistance of the heat sink sensor.

Thermistor	Control bd J3 pins 1-2
------------	------------------------

Temperature (C)	Resistance (Ohms)
20	25000
25	20000
30	16102
35	13048
40	10636
80	2506
90	1827
100	1353
110	1017
120	775

4.6.9 E-base Motor and Canopy Motor

If you must replace a footswitch when the bed is all the way down, use pedal screen on service screen to raise or lower the bed.

To troubleshoot the canopy clutch and roll pins, run the e-base all the way up. Take the bottom end cap off the rail and the back panel off the electrical enclosure. Use a flash bulb to look up into the rail and see what moves when the canopy slips. If the motor coupler is turning, then either the slip clutch or one of the roll pins is missing or defective. If the clutch turns and not the sprocket, then the problem is a defective slip clutch. If neither turns, the problem is probably a sheared roll pin.

The e-base motor and canopy motors are driven by the same circuits. The e-base is always driven at 24 volts DC (acceptable range 24-32), and the canopy motor is driven at 24 volts (acceptable range 24-32) when going up and 12 volts (acceptable range 12-16) when going down.

The following chart shows the control signal values and the output voltages for each of the motor conditions.

Switch	Control Signals, Relay Board				E-base		Canopy	
	J37 pin 23	J37 pin 26	J37 pin 24	J37 pin 27	J45-1	J45-2	J46-1	J46-3
	24V SELECT	E/H ACTIVATE	NVERTPOLARITY	E/H SELECT				
Raise canopy	0	0	1	1	NA	NA	+24V	Gnd
Lower canopy	1	0	0	1	NA	NA	Gnd	+12V
Raise E-base	0	0	1	0	+24V	Gnd	NA	NA
Lower E-base	0	0	0	0	Gnd	+24V	NA	NA
None	NA	1	NA	NA	NA	NA	NA	NA

4.6.10 Rail Lift Belt Failure

The following symptoms might be observed that indicate possible rail lift belt (drive belt) failure (rail belts that have broken rungs after extended use):

- Canopy rises slowly and sticks just when doors are opening (4-6 inches from top of canopy travel)
- Heater doors don't open fully (lift hasn't traveled far enough to complete door opening mechanism)
- "In transition" alarm sounds when:
 - Canopy is not all the way up to activate microswitches, OR
 - Heater doors aren't fully open to activate their microswitches

If these symptoms exist, check for rail lift belt failure by doing the following:

1. Remove the canopy motor.
2. Slide up the decorative strip to expose the endcap screw. Remove the lower endcap.
3. Using a bright flashlight pointing up in the bottom of the rail, look inside the rail assembly through the shipping lock-down screw slot near bottom of the rail. Look toward the back (North) to observe rail lift belt.
4. Manually raise and lower the canopy, slowly. (If possible, have a second person do this for you.) While the canopy is being slowly raised and lowered, visually inspect the belt (via the screw slot) to determine whether there are any rungs on the belt that are stripped/broken.
5. Inspect the entire belt by manually sending the canopy through its full cycle, especially the links as the belt nears the top of upward travel.

When ordering the new belt, order the following parts as it is sometimes difficult to remove the screws from the belt block adjuster without stripping the heads. If this happens it is easiest to just replace the block and screws.

Part Number	Quantity	Description
6600-1372-500	1	Lift Belt
6600-1360-500	1	Belt Block Cover
6600-1357-500	1	Belt Adjuster, Bottom
6600-1151-400	2	Screw, M3X10 Flat Head Socket

NOTE: For instructions on replacing the belt, refer to section 5.4.3.4.

4.6.11 Troubleshooting the 50 Pin Ribbon Cable

All of the communication between the control and relay boards passes through the 50 pin ribbon cable. Many of the troubleshooting procedures in this manual recommend that you verify continuity for specific pins in the cable. Because it is difficult to remove and measure the cable without possibly changing the resistance, it is suggested that you keep a spare 50 pin ribbon cable to use as a troubleshooting tool.

4.6.12 Troubleshooting the Toroidal Transformer

Perform the following tests in service mode. The referenced voltages should always be present when the unit is in service mode. In normal operating mode, the voltages are not present if safety relay 2 contacts are open.

1. Check the output voltage of the toroidal transformer at J44 pins 1-2 and at J44 pins 3-4. Voltages should be about 15 volts AC .
2. If the voltage is not present verify that mains voltage is present at the primary input to the toroidal transformer in service mode. This voltage can be measured at relay board connector J51 pins 1-2. It can also be measured at the configuration plug on the toroidal transformer pins 1-4.
3. If the primary voltage is present and there is no output voltage, the toroidal transformer is defective.
4. If the primary voltage is not present, then replace the relay board.

4.6.13 Interpreting Serial Numbers

Datex-Ohmeda products have unit serial numbers with coded logic which indicates a product group code, the year of manufacture, and a sequential unit number for identification. The serial number is in the following format:

AAAX11111

The X represents an alpha character indicating the year the product was manufactured; H = 2004, J = 2005, etc. I and O are not used.

4.7 Servo Controlled Oxygen

4.7.1 Servo Controlled Oxygen Service Screen

To access the service screens, hold in the override button (>37) during power up until the software revision screen appears. Release the button and the first service screen will appear. Select DOWN on the first screen to go to the second service screen. Select Servo O2 to bring up the Servo Controlled Oxygen service screen.



Figure 4-7 Servo Controlled Oxygen Service Screen

Item	Description
V1	Select to open or close supply valve one in the valve housing located beneath the electrical enclosure.
V2	Select to open or close supply valve two in the valve housing located beneath the electrical enclosure.
VC	Select to open or close calibration valve in the sensor housing located beneath the bed. Open is calibration position and closed is the normal operation position. The calibration fan is on and the cooling fan is off when VC is open. NOTE: The cooling fan is on whenever the Servo Controlled Oxygen service screen is selected and VC is closed.
K1	Select to open or close the relay on Relay PCB that powers the valves.
Cal O2	Initiates calibration routine.
oxygen0	Oxygen reading in percent from first sensor cell:
oxygen1	Oxygen reading in percent from second sensor cell:
sensor0	Voltage output in millivolts from first sensor cell.

Item	Description
sensor1	Voltage output in millivolts from second sensor cell. NOTE: The following information applies to the oxygen0, oxygen1, sensor0, and sensor1 values: <ul style="list-style-type: none"> For software version 1.40 or previous versions, 23 mv - 280 mv = 21% - 100% O₂. For software version 1.50 or later versions, 5 - 90 mv = 21 - 100% O₂.
temp	Temperature in degrees Celsius read from a sensor inside the sensor housing located beneath the bed. Refer to temperature to resistance curve in the Tips section (4.7.3).
humidity	Relative humidity in percent read from a sensor inside the sensor housing located beneath the bed.

4.7.2 Servo Controlled Oxygen Alarm Messages

Alarm Message	Meaning	Cause	Action
Low Oxygen	Sensor1 reading is > 3% below the oxygen set point 7 minutes after a set point change or the OmniBed canopy was closed.	Low O ₂ supply pressure or flow.	Be sure supply is greater than 45psi (310 kPa) and flow rate is greater than 45 L/min. If flow rate is <45 check that the inlet screen in the regulator is not occluded. Clean or replace screen.
		Inlet screen occluded.	
		Air leaks into infant compartment.	Be sure all doors and portholes are closed.
		Supply Valve not opening.	Check supply valves. Refer to the Tips section (4.7.3).
		Endcap safety valve not opening.	Check valve and spring assembly. Refer to the Tips section (4.7.3).
		Calibration valve is not closing.	Check the calibration valve. Refer to the Tips section (4.7.3).
High Oxygen	Sensor1 reading more than 3% above set point	Infant compartment vents occluded.	Check to be sure that the two vents in the infant compartment under the bed are not occluded.
		Oxygen set point recently lowered.	Allow time for oxygen level to drop.
		Supply valve(s) not closing.	Check supply valves and kinked hoses. Refer to the Tips section (4.7.3).

Alarm Message	Meaning	Cause	Action
Oxygen Probe Failure	One of the sensors is reading out of range (23-280 millivolts on units with 1.3 software or higher) or the difference between the two O2 sensors is above 3%.	Defective Sensor(s)	In service mode sensor0 and sensor1 should be 23-280. If outside this range replace the sensors. If in range ensure oxygen0 and oxygen1 read within 3% of each other or replace the sensors.
		Leak or occlusion in sensor housing area.	Be sure sensor housing is seated properly and the retaining screws are tight. Be sure sensor gaskets are in place and the tubing is seated correctly in the connectors. Check to be sure that the two vents in the infant compartment under the bed are not occluded.
		Defective cable or connection.	Measure the voltage at J85.8-J85.7(sensor0) and J85.6-J85.7(sensor1) and compare them to displayed sensor0 and sensor1. If the measurement is the same as the displayed, check the cable and sensor contacts.
		Defective Servo O2 board.	If the measurement is not the same as the displayed, replace the Servo O2 board.
O2 Cal Lost-No O2	Servo oxygen unit has never been calibrated. Unit will not operate until initial calibration is performed.	Perform oxygen calibration.	Run calibration.
	Cell voltage less than 33 mV.	Earlier software versions did not store voltages this low.	Replace display software with 1.62 or higher.
Oxygen System Failure 1	The sensor plug thermistor temperature reading is out of the range: 15C-55C.	Unit is cold: <15 degrees C.	Allow unit to warm up.
		Cooling fan is not running when the sensor housing temperature gets above 50 degrees.	Test the cooling fan. Refer to the Tips section (4.7.3).
		Defective sensor plug thermistor or cable.	Disconnect the cable and measure the resistance of the thermistor between J85.4 and J85.5. Refer to R/T chart (the temperature to resistance curve) in the Tips section (4.7.3). If sensor is shorted, open, or values don't agree with the R/T chart, replace the sensor plug assembly or the cable.
		Defective servo O2 board.	If resistance is in range replace the servo O2 board.
Oxygen System Failure 2	The RH reading is out of valid range: 1-99. When out of range it displays 0 in service mode.	Defective sensor plug.	Measure the humidity sensor voltage between J85.2 and J85.1. If the voltage is outside the range of 0.7V- 4.0V, replace the sensor plug assembly.
		Defective servo O2 board.	If it is in the correct range, replace the servo O2 Board.
Oxygen System Failure 3	The checksum test performed during power up testing failed.	Defective Microcontroller.	Replace microcontroller U6 on the Servo O2 board.

Alarm Message	Meaning	Cause	Action
Oxygen System Failure 4	Analog to digital converter circuit self test failed. The reading of Vtest is out of the valid range:1.216V-1.254V.	Defective Servo O2 board.	Replace servo O2 board.
Check O2 supply	After calibration, both supply valves are opened and after approximately 20 seconds, sensor1 reading is not greater than 23%.	O2 supply is not connected.	Verify O2 supply, minimum 45psi (310kPa) is connected to the inlet.
		Kinked hoses in sensor housing.	Check hoses.
Oxygen System Failure 5	Check O2 Supply alarm has been silenced twice and the sensor1 reading is still not greater than 23%.	O2 supply is not connected.	Verify O2 supply, minimum 45psi (310 kPa) and 45 L/min is connected to the inlet.
		Calibration valve stuck in calibration position.	Check the calibration valve. Refer to the Tips section (4.7.3).
		Supply valves not opening.	Check supply valves. Refer to the Tips section (4.7.3).
		Leak or occlusion in sensor housing area.	Be sure sensor housing is seated properly and the retaining screws are tight. Be sure sensor gaskets are in place and the tubing is seated correctly in the connectors. Check to be sure that the two vents in the infant compartment under the bed are not occluded.
Oxygen System Failure 6	The Giraffe control board cannot communicate with Servo O2 board.	Defective Servo O2 board.	Replace servo O2 board.
		Defective Cable.	Check that the cable between the Giraffe control board and the Servo O2 board is seated properly.
Oxygen System Failure 7	Power up test detected a problem with the watchdog circuit.	Defective Servo O2 board.	Replace Servo O2 board.
Calibration failed	In calibration mode, after 5 minutes, both sensors are not reading between 23 and 55 millivolts so the unit cannot calibrate.	Calibration valve is not opening or the calibration fan is not turning on.	Check the calibration valve and fan. Refer to the Tips section (4.7.3).
		Defective sensors.	Replace the sensors.

Alarm Message	Meaning	Cause	Action
FiO ₂ >26%	Elevated oxygen levels in patient compartment not controlled by the servo O ₂ system.	Auxiliary source of oxygen supply in patient compartment.	Check the secondary sources, such as ventilator or resuscitation bag.
		Leak in the servoO ₂ system supply valve.	Check supply valves. Refer to the Tips section (4.7.3).



SENSITIVE TO ELECTROSTATIC DISCHARGE CAUTION

An Electrostatic Discharge (ESD) Susceptibility symbol is displayed to alert service personnel that the part(s) are sensitive to electrostatic discharge and that static control procedures must be used to prevent damage to the equipment.

4.7.3 Servo Controlled Oxygen Troubleshooting Tips

4.7.3.1 Check Supply Valves and Endcap Safety Valve



Power up unit in service mode. Close the canopy. Select Servo O₂ on second page. Be sure O₂ is connected. Open V1. You should hear gas flow. Close V1, open V2. You should hear gas flow. Close V2, gas flow should stop. If supply valves are open and there is no gas flow, check that the endcap safety valve located in the bottom of the rail is not stuck in the closed position. Check that the two-way valve is not occluded or the spring assembly has not failed.

If both valves are not opening, test the fuses and supply valves. Disconnect J83 at the Servo O₂ board. Measure the resistance on harness pin 1 to pin 2. It should be the supply valve resistance (50 to 100 ohms). If not, the fuse is opened or the supply valve is defective. Repeat for the second supply valve with pins 3 to 4. If the valves check OK, the Servo O₂ board is defective.

NOTE: With one supply valve open the flow rate should be a minimum of 35 L/min. With both supply valves open, the minimum flow rate should be 40 L/min. If the flow rate is low, check that the regulator inlet screen is not occluded.

4.7.3.2 Check Calibration Valve/Calibration Fan



The calibration valve is located beneath the chassis in the sensor housing. The calibration fan is mounted in the sensor housing next to the calibration valve. Power up unit in service mode. Select Servo O₂ on second page. Open VC. This should open the calibrate valve and turn on the calibration fan. Verify the calibration fan is running. If the fan is running then the Servo O₂ board is OK and the calibration valve may be defective. If the fan is not running check the control signal from the Servo O₂ board to verify voltage is present when VC is opened to determine if the fan or board is defective.

4.7.3.3 Check Cooling Fan



The cooling fan is mounted to the sensor housing door on the chassis cover. Power up unit in service mode. Select Servo O2 on second page. The cooling fan should be running.

If fan is not running verify 10.0 - 13.2 Volts at J86-1 to J86-2. If voltage is present the fan is defective. If voltage is not present the Servo O2 board is defective. Open VC, you should hear a click and the cooling fan should stop. If the fan does not stop the Servo O2 board is defective.

4.7.3.4 Sensor Housing Temperature Sensor Temperature to Resistance Curve

Temperature	Resistance
15C	15.720 kohm
25C	10.000 kohm
30C	8.056 kohm
35C	6.530 kohm
40C	5.326 kohm
45C	4.369 kohm
50C	3.604 kohm
60C	2.491 kohm

Chapter 5: Repair Procedures



SENSITIVE TO ELECTROSTATIC DISCHARGE CAUTION

An Electrostatic Discharge (ESD) Susceptibility symbol is displayed to alert service personnel that the part(s) are sensitive to electrostatic discharge and that static control procedures must be used to prevent damage to the equipment.



WARNING:

After performing any repair or calibration, always perform the Service Checkout Procedure before putting the unit back into service.

5.1 Canopy Removal for Replacement

1. If the unit has original canopy seals, plan ahead about canopy seal parts. Choose one of the following:
 - If you plan to transfer the seal parts from the old canopy to the new, order the corner label set (6600-2358-100, set of two), as these cannot be reused.
 - If you plan to replace the seal parts, order the Enhanced Seal Retrofit Kit (M1208286).
2. Lock the rails in the intermediate position:
 - a. Raise the canopy.
 - b. Slowly lower the canopy until the rail locking screws align with the horizontal oblong holes in the rails. (Refer to Figure 5-1.)
 - c. Use a 4 mm hex key to turn the rail locking screws counter-clockwise until they lock both rails in place.
3. Lower the elevating base to a convenient height for reaching the canopy.
4. Switch off the unit and disconnect the power cord.
5. Cover the bed with a sheet to catch any parts that may fall.
6. Remove the canopy from the unit:
 - a. Using a small straight-blade screwdriver, remove the six arrow clips that secure the soffit beneath the north end of the canopy. Remove the soffit. (Refer to Figure 5-1.) Save the six arrow clips and soffit for later installation.

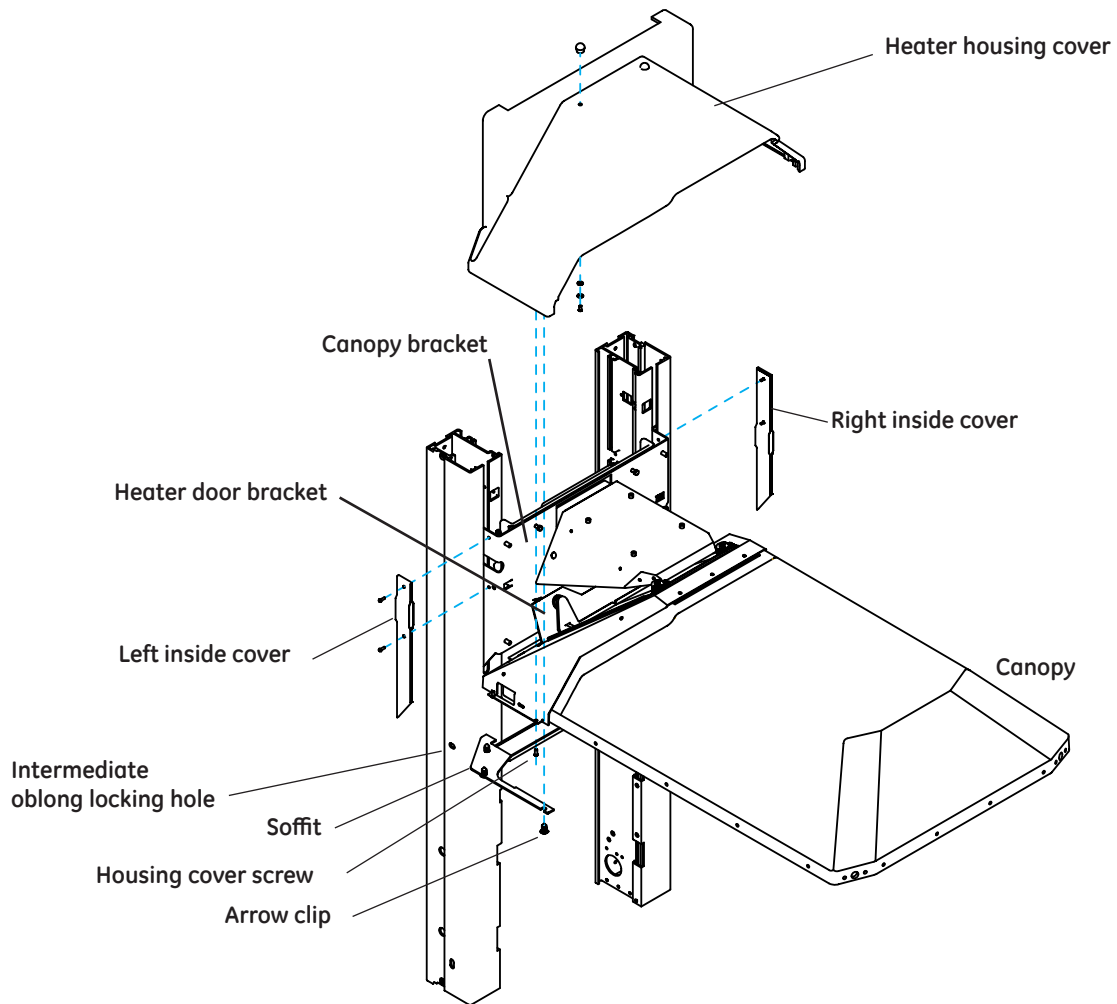

Figure 5-1 Heater Housing Cover and Soffit

- b. Using a 2.5 mm hex key, remove the four screws that secure the heater housing cover to the heater door bracket. Remove the heater housing cover. Save the four screws and heater housing cover for later reinstallation.

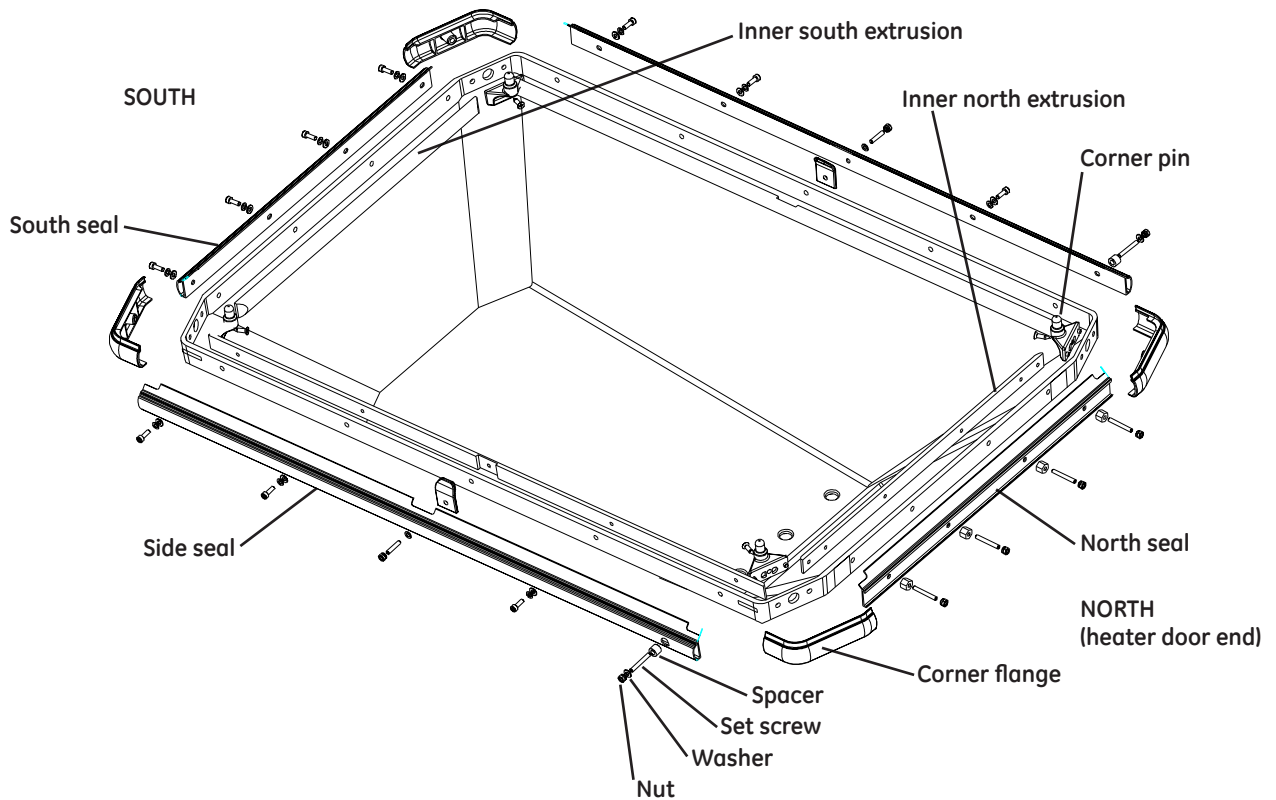

Figure 5-2 Original Seal Parts

- c. Using a 2.5 mm hex key or small Phillips screwdriver, remove and discard the four screws that secure the corner pins to the four corner flanges. Hold the corner pins in place while removing the screws. Remove and discard the corner pins. Remove and discard the two south corner flanges. (Removal of the north corner flanges is described in section 5.2.1.)

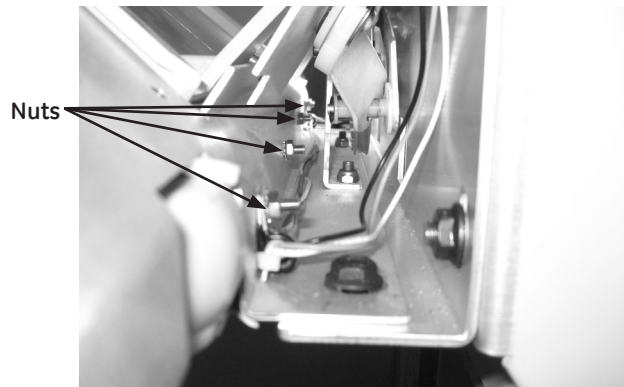

Figure 5-3 Nuts

- d. Using a 7 mm socket or wrench, remove and discard the four nuts and four star washers across the north end of the heater door bracket that secure the canopy to the heater door bracket. (Two of the nuts are accessed through the north access holes in the canopy bracket.) Take note where cable routing clips are secured, for later reassembly.

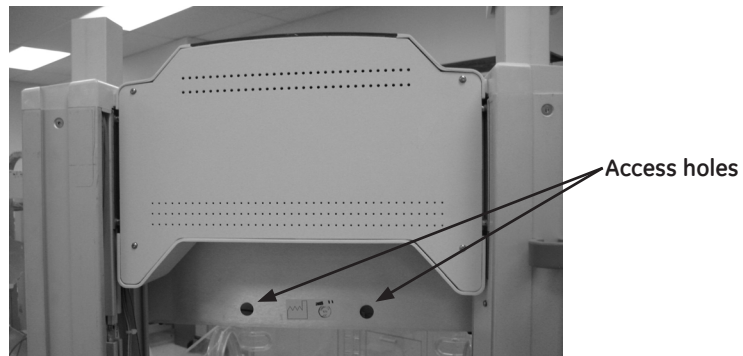

Figure 5-4 Access Holes

- e. Using a 7 mm socket or wrench, remove and discard the nuts and star washers from the set screw located on each side of the heater door bracket. Using a 2 mm hex key, remove and discard the two set screws and the two spacers from the side seals. (Refer to Figure 5-2.)

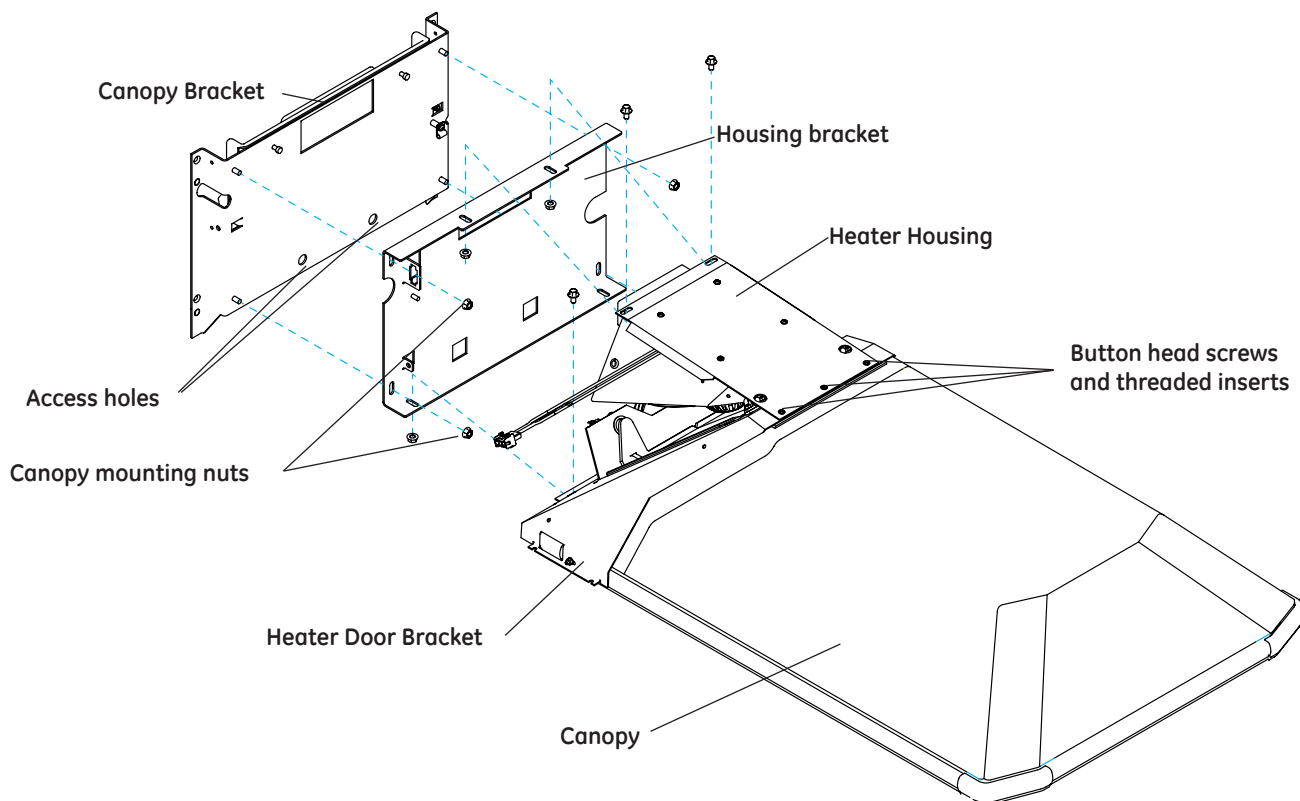

Figure 5-5 Canopy, Bracket, and Heater Housing

- f. Support the canopy and hold the threaded inserts inside the canopy while using a 2.5 mm hex key to remove the three button head screws across the top of the canopy. This step may require the assistance of another person to support the canopy. Save all hardware from this step for reassembly (the threaded inserts, three button-head screws, lock washers, and flat washers).

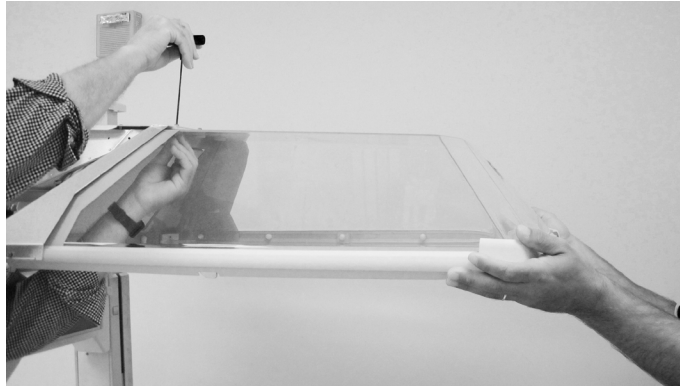

Figure 5-6 Two People Needed for this Step

- g. Lift the canopy slightly from the south to pivot the north end of the canopy away from the heater door bracket.
 - h. Turn the canopy upside down on the clean and soft work surface to avoid scratching the canopy. Save the canopy for later reassembly.
7. Choose one of the following:
 - Transfer the remaining parts from the old canopy to the new. In this case, order the corner label set (6600-2358-100, set of two), as these cannot be reused.
 - Use the Enhanced Seal Retrofit Kit (M1208286) to replace the seal hardware.
8. Reassemble in reverse order. If alignment is required, refer to the “5.6.1.1 Realigning the Canopy” section.

5.2 Servicing the Canopy Seals

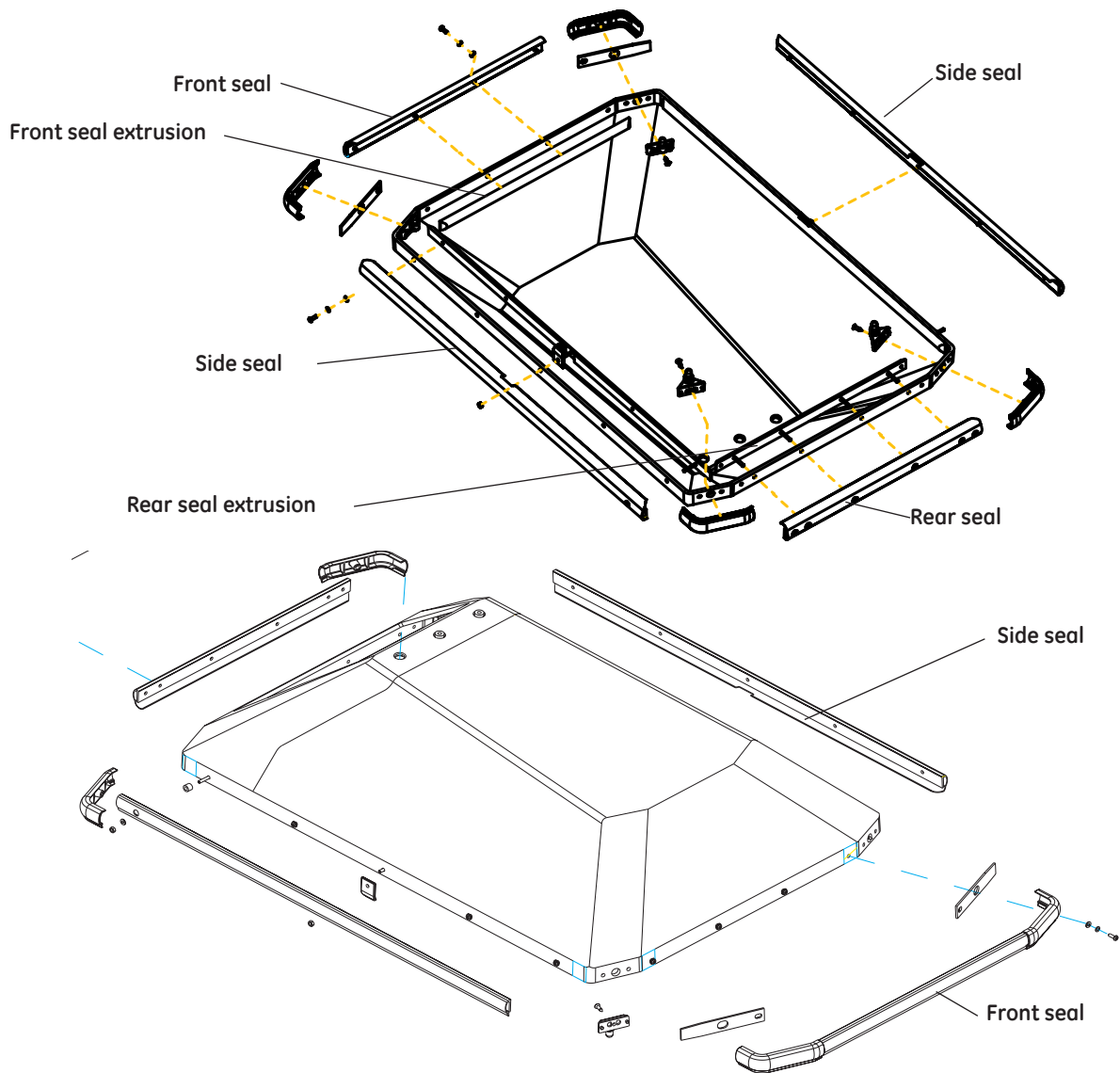

Figure 5-7 Canopy Seals and Extrusions

5.2.1 Servicing Original Canopy Seals

Use the Enhanced Seal Retrofit Kit (M1208286) to replace the seal hardware.

1. Remove the canopy from the unit as described in the “5.1 Canopy Removal for Replacement” section.
2. Remove the remaining seal parts from the upside-down canopy:
 - a. Remove and discard the two north corner flanges.
 - b. Using a 2 mm hex key, unscrew and discard four set screws in the north seal. Remove and discard the north seal and inner north extrusion.
 - c. Unsnap the side seal cover. Wedge a blunt object into each side seal to keep it open while you remove hardware.



Figure 5-8 Wedging a Blunt Object to Keep Seal Open

- d. Remove and discard the three screws (using a 2.5 mm hex key) and the two M4 nuts (using a 7 mm socket) from each side seal extrusion.
- e. Remove and discard the side seals, side extrusions, and clear plastic door stops.
- f. Using a 3 mm hex key, remove and discard the four screws that secure the south seal to the south seal extrusion.
- g. Remove and discard the south seal.
- h. Remove and discard the white labels from the south corners of the canopy and clean off the adhesive with Cavicide.



CAUTION:

Do not use adhesive removers as they could damage the canopy.

3. Clean the canopy before reinstallation.

At this point you should have the following parts saved:

- Six arrow clips and soffit
- Four screws and heater housing cover
- Threaded inserts, three button-head screws, lock washers, and flat washers
- Canopy

Refer to the following figure while performing the remaining steps in this section:

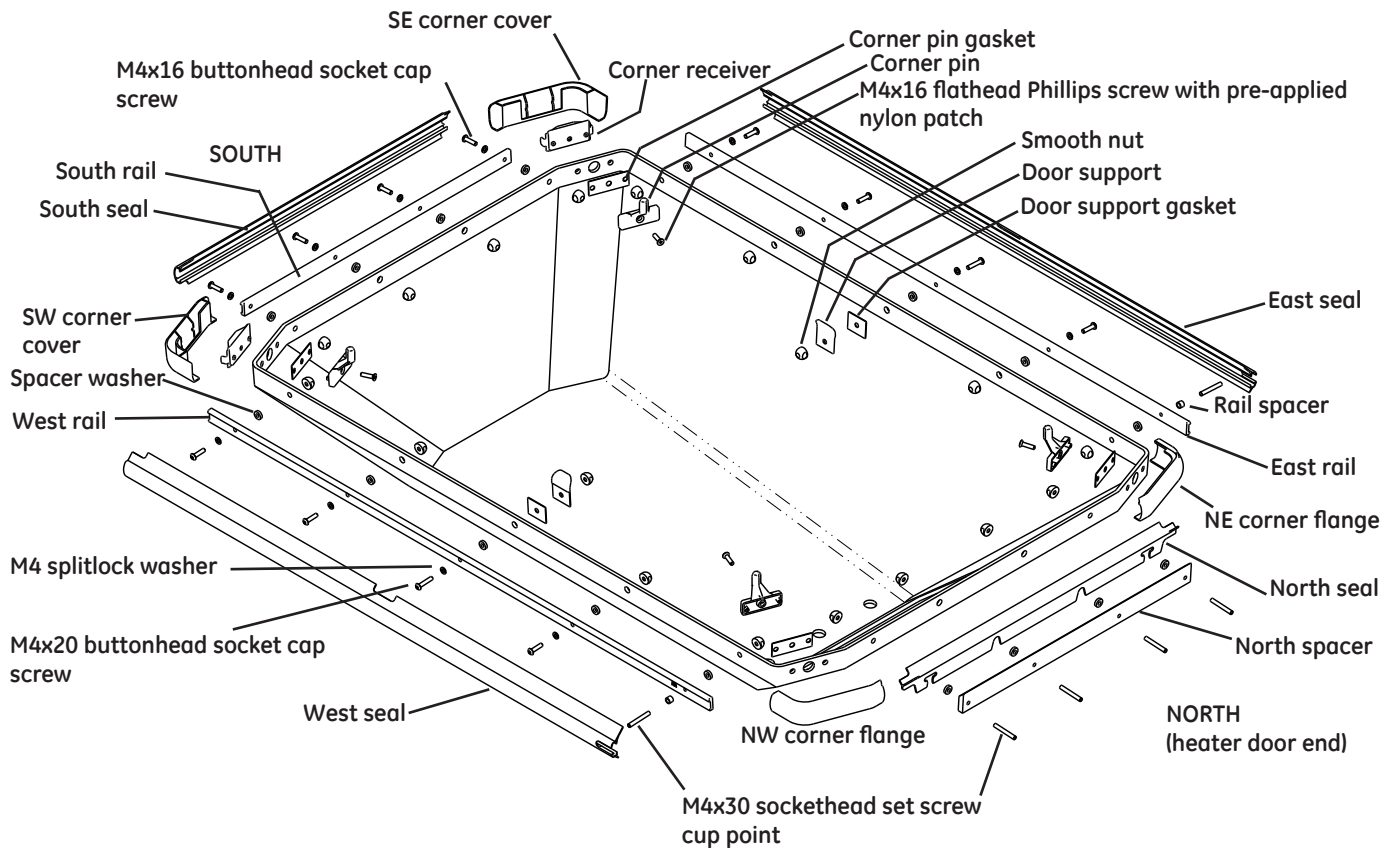

Figure 5-9 Enhanced Seal Parts

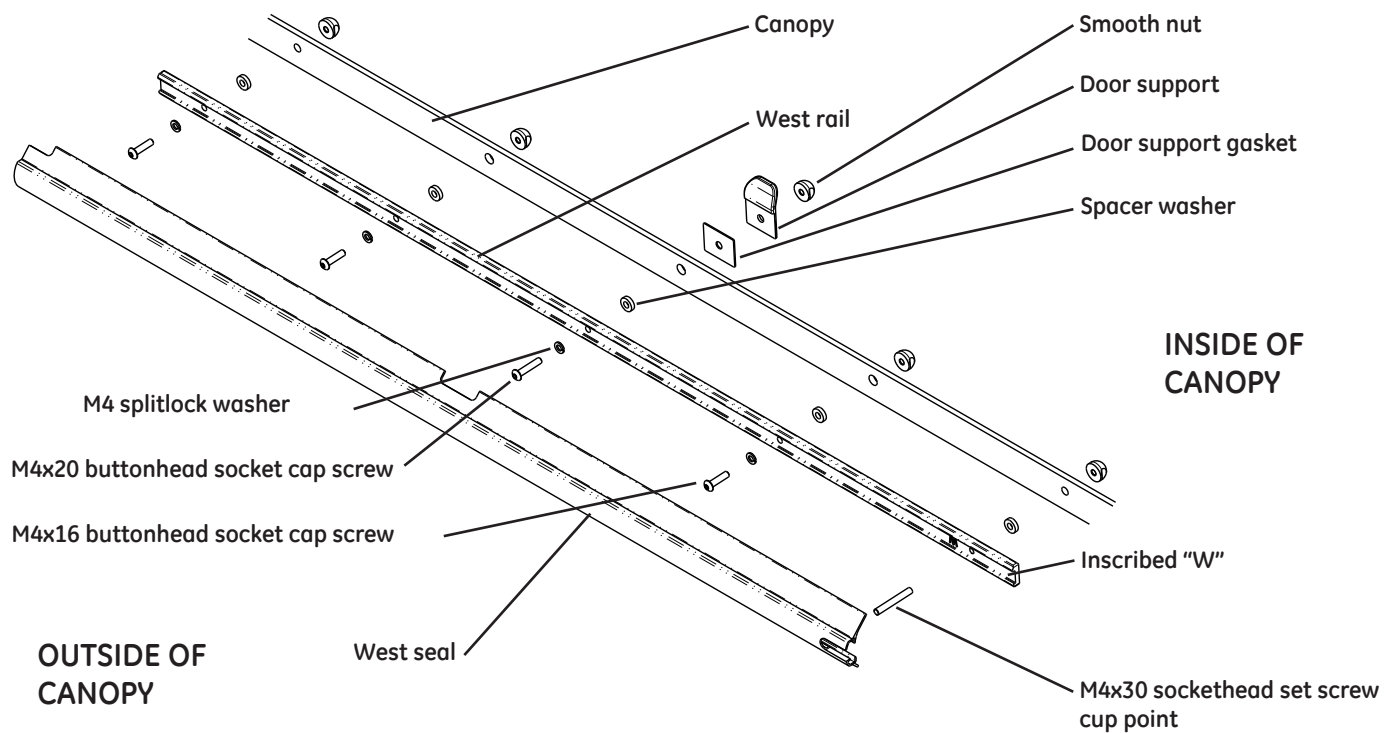

Figure 5-10 West Side Seal Parts

NOTE: The east side seal parts are symmetric to the west side seal parts.

4. Install side seal parts on the upside-down canopy. Start by installing all hardware finger-tight:
 - a. Install the east and west seal guide rails with smooth nuts, spacer washers, lock washers, and screws from kit, as shown in Figure 5-10. The larger lobe of each rail should be closest to the edge of the canopy, as shown in Figure 5-12. (This indicates which way is up on each seal.) The rails have "E" and "W" inscribed for east and west. These letters go toward the heater door cutout end of the canopy.
 - b. Position the spacer washers between the rail and canopy for assembly.

NOTE: The cutouts in the north seal may be used to help with this positioning of these washers as shown in the following figure:



Figure 5-11 Using North Seal to Help Position Washers

- c. Thread the set screw into the threaded hole in the guide rail near the “E” or “W” inscription. Refer to Figure 5-10. The socket of the set screw should be on the outside of the canopy.

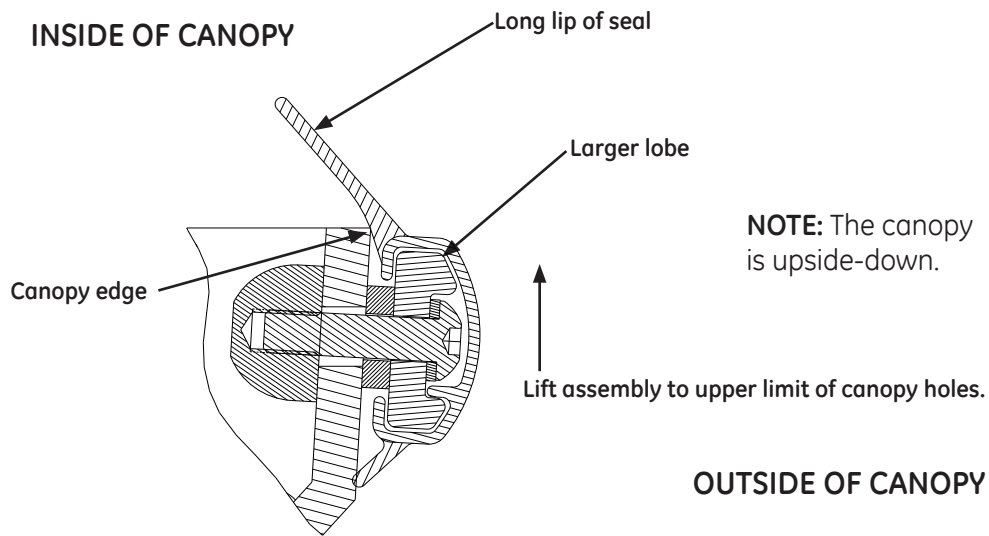

Figure 5-12 Seal Cross-section

- d. At the middle position of the long canopy sides, install the longer screw, lockwasher, spacer washer, gasket, door support, and smooth nut, as shown in Figure 5-10.
- e. Slide the seals on both sides, for alignment purposes. Lift the seal assembly to the upper limit of the canopy holes. Refer to Figure 5-12.
- f. Using a 10 mm open-end wrench, tighten all nuts and screws until they feel snug.
- g. Remove seal and verify that the lock washers are compressed flat. If necessary, tighten with 10 mm open-end wrench and 2.5 mm hex key.



CAUTION:

Do not over-tighten the hardware.

- h. Install and remove seals to check for easy installation.

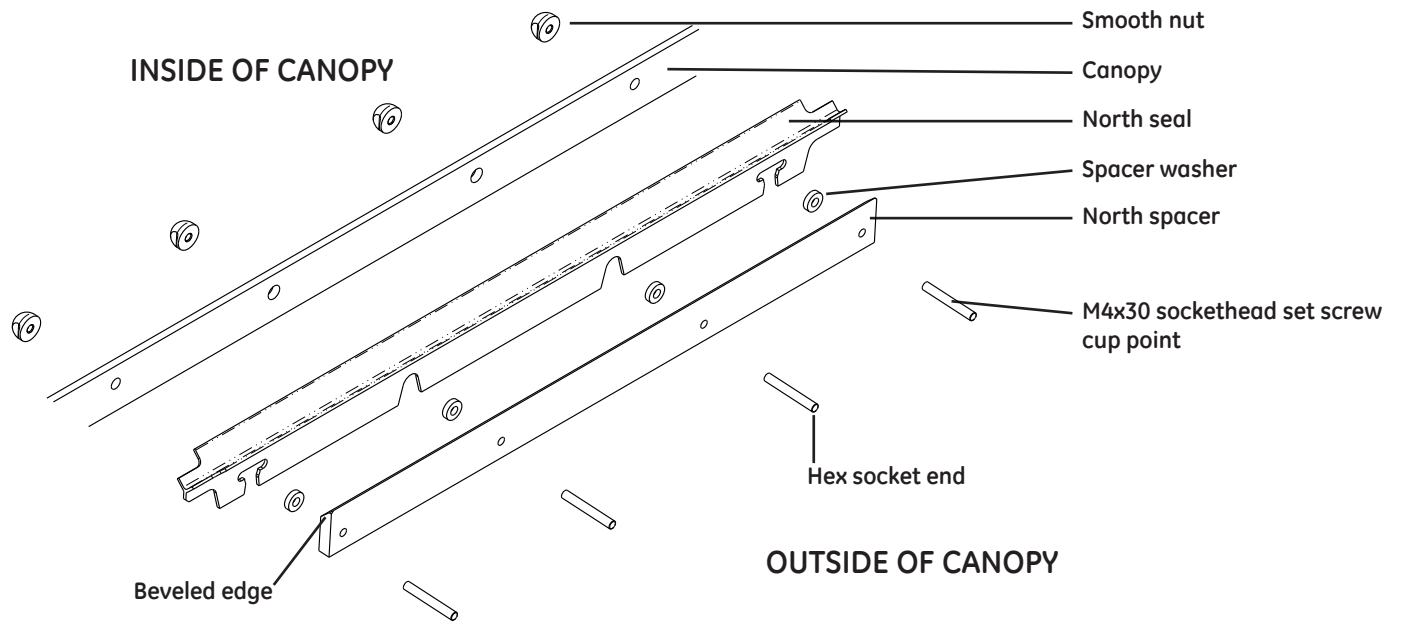

Figure 5-13 North Seal Parts

5. Install north seal parts on the upside-down canopy:

- a. Orient the north spacer with the beveled side toward the canopy edge, as shown in Figure 5-13 and Figure 5-14.

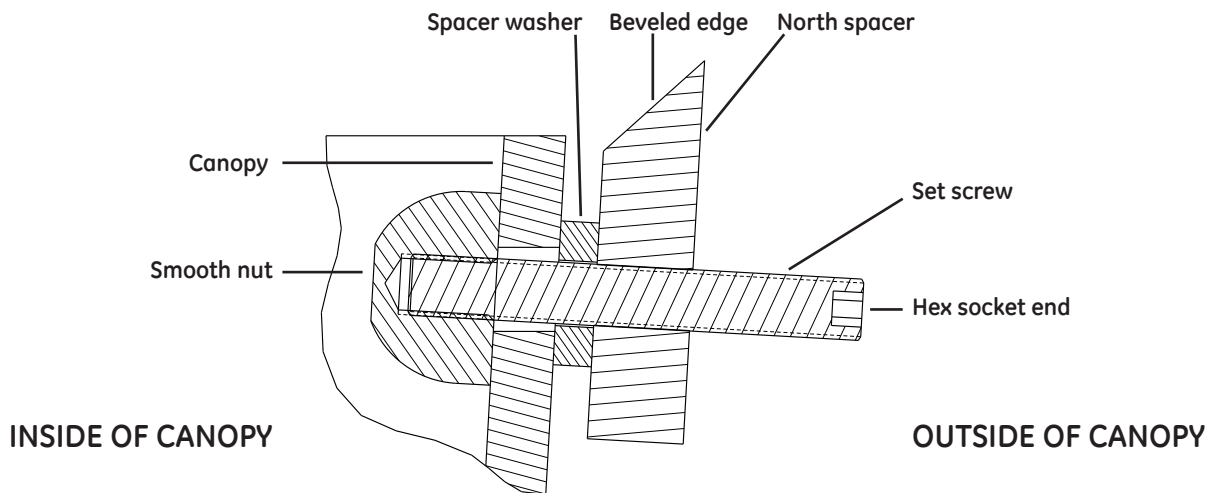

Figure 5-14 Beveled Side of North Spacer Toward Canopy

- b. Start all set screws in the spacer, with the hex socket end of the screw pointing to the outside of the canopy.
- c. Add plastic spacer washers to the set screws.
- d. Install the north spacer and washers to the canopy with smooth nuts.

- e. If your canopy has six holes across the north end, install parts for the middle four holes as shown in Figure 5-13 and install parts for the remaining two holes as shown in Figure 5-15. The parts for these two holes serve to fill these two holes.

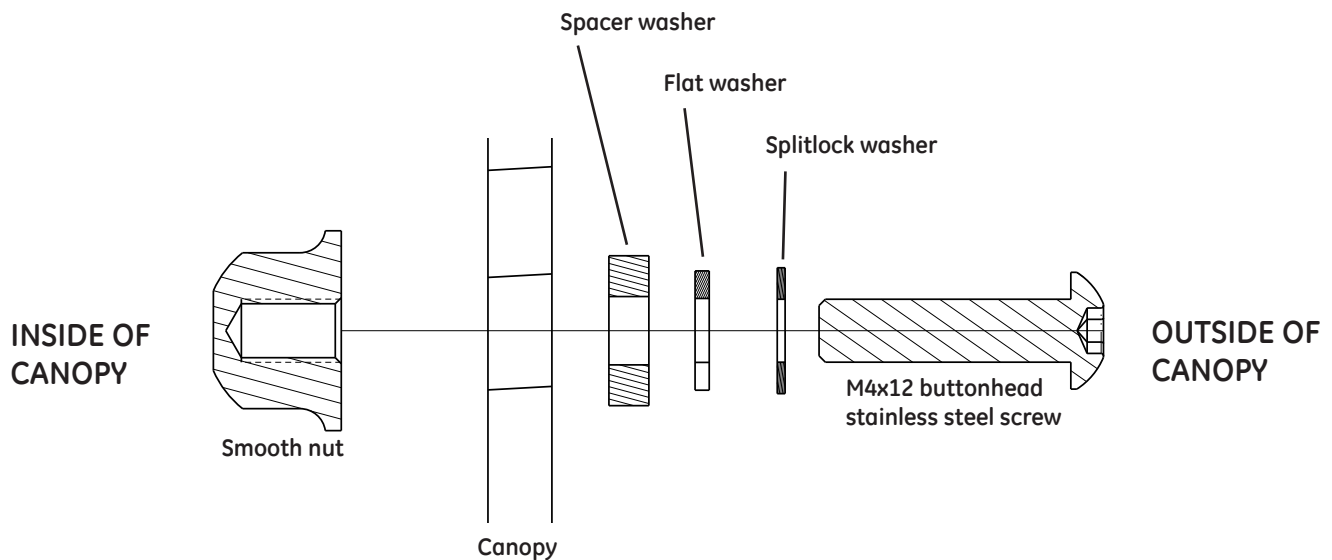

Figure 5-15 Hole Fill Assembly (2x) for Canopies with Six Holes across North End

- f. Snap the north seal vertically between the north spacer and canopy for a fit-check. Make sure that the red/orange indicator is not visible from inside the canopy.
- g. Using a 10 mm open-end wrench, tighten all smooth nuts.



CAUTION:

Do not over-tighten the hardware.

- h. Remove the north seal.

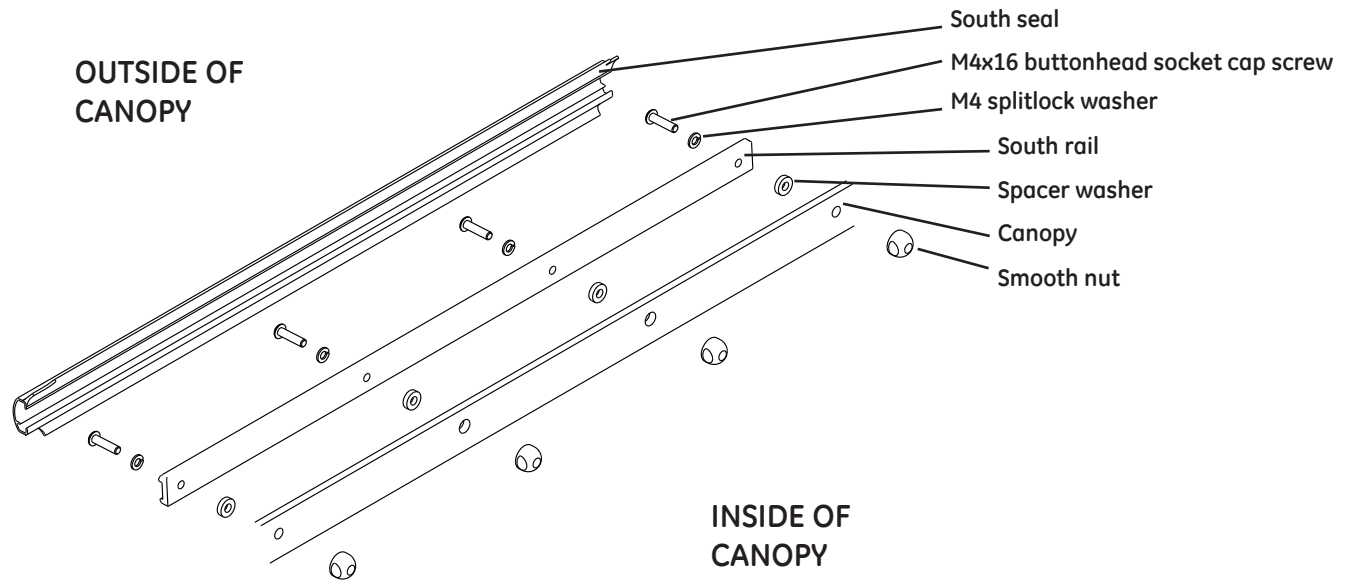

Figure 5-16 South Seal Parts

6. Install south parts on the upside-down canopy:
 - a. Install the south guide rail with the four button head screws (2.5 mm hex key), washers, and lock washers provided with the kit. Install all hardware finger-tight.
 - b. Slide seal on, for alignment purposes. Lift the seal assembly to the upper limit of the holes.
 - c. Tighten all nuts and screws until they feel snug.
 - d. Remove seal and verify that the lock washers are compressed flat. If necessary, tighten with 10 mm open-end wrench and 2.5 mm hex key.



CAUTION:

Do not over-tighten the hardware.

- e. Install and remove seal to check for easy installation.

7. Install corner parts:

- a. Using a Phillips screwdriver, install the corner pin, gasket, and corner receiver on the upside-down canopy at each south corner (the corners *opposite* the heater door cutout). The corner receiver rib should be closest to the canopy edge.

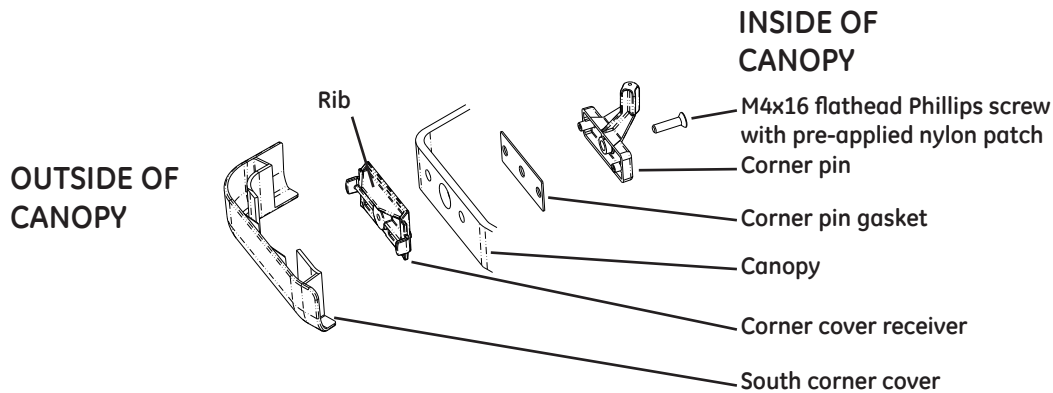

Figure 5-17 South Corner Parts

- b. Using a Phillips screwdriver, install the corner pin, gasket, and corner flange on the upside-down canopy at each north corner (the corners *nearest* the heater door cutout):

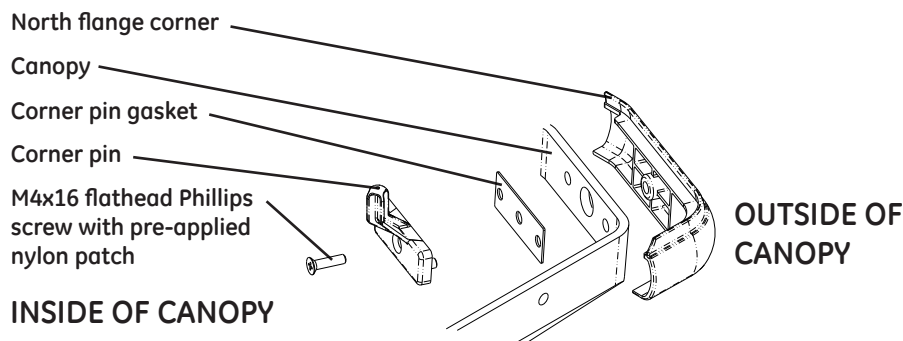

Figure 5-18 North Corner Parts

- c. Make sure that all pins point up. (The pins should point up when the canopy is upside-down, down when the canopy is right-side up). Make sure all gaskets are on the inside.
8. Reinstall the canopy on the unit. This step may require the assistance of another person, as in Figure 5-6:
- a. Using a 2 mm hex key, screw the set screws in the east and west rails at the E and W marks until they are flush with the rails.
 - b. Turn the canopy right side up.
 - c. Insert the canopy north end, with the four set screws protruding, into the heater door bracket on the unit.
 - d. Hold the canopy in place and hold the threaded inserts inside the canopy while using a 2 mm hex key to install the three button head screws across the top of the canopy.

9. Install additional hardware:
 - a. Make sure that four set screws are inserted into the heater door bracket. Also make sure that the set screw on each side of the canopy at the display end is aligned with the hole in the heater door bracket.
 - b. Using a 7 mm socket or wrench, install the four nuts and four star washers that secure the canopy to the heater door bracket. Remember to reinstall the cable routing clips on the outboard studs.
 - c. Slide each rail spacer between rail and heater door bracket to align with each set screw on the side rails at the E and W marks. Refer to Figure 5-19. Tighten smooth nuts finger-tight until set screw protrudes through spacer and heater door bracket.

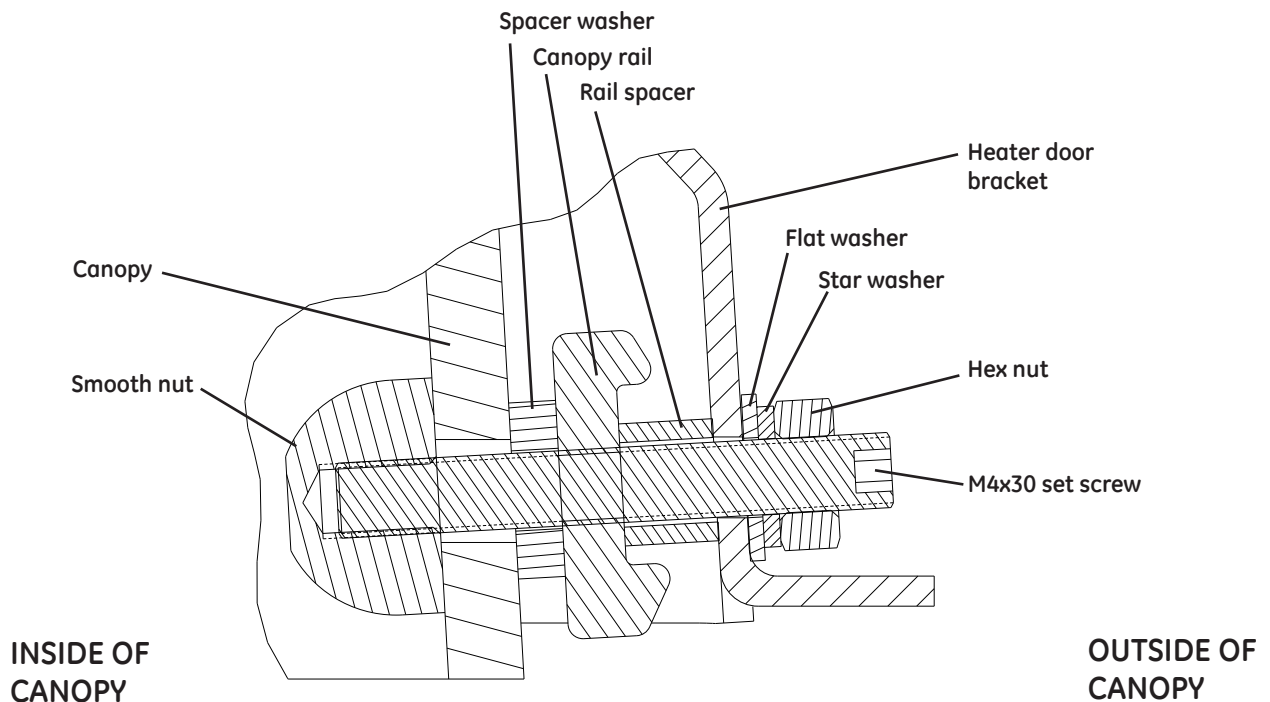

Figure 5-19 Installing Rail Spacers

- d. Tighten smooth nut with a 10 mm open end wrench. Make sure rail spacer is still in place between the heater door bracket and rail.



CAUTION:

Do not over-tighten the hardware.

- e. Assemble the star washer and nut on the outside of the heater door bracket and tighten the nut.

10. Make sure that all seals can be easily installed:

- a. At the north end of the canopy, insert the north notched seal in the slot in front of the red/orange warning spacer and slide it up to snap it into place. You should hear an audible snap from each end. It does not matter which seal lip faces out.

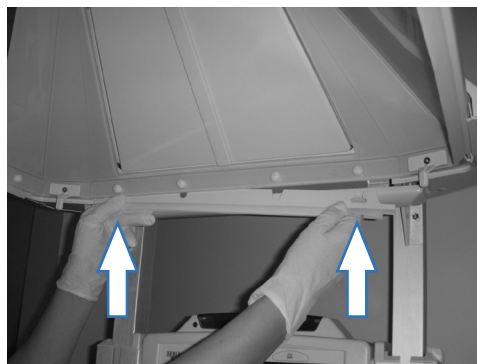

- b. Starting with the south end, slide the slotted end of each long seal over a guide rail on the side of the canopy, with the large seal lip down.

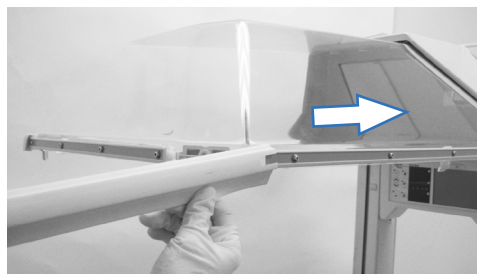

Slide the slotted end toward the display until it stops. The seal should be flush with the end of guide rail. Repeat for the remaining side.

- c. Slide the short seal, large lip down, over the short guide rail on the south end of the canopy. The seal should be flush with ends of guide rail.

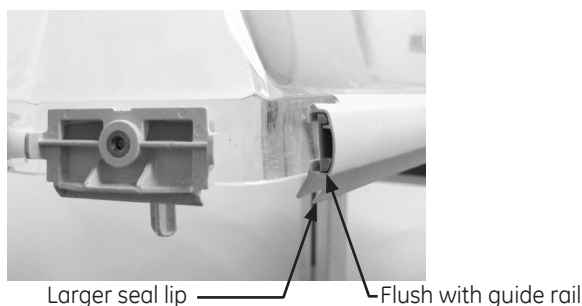

- d. Select a corner cover that fits each corner and snap it down over the corner receiver. You should hear an audible snap. Repeat for the remaining corner.

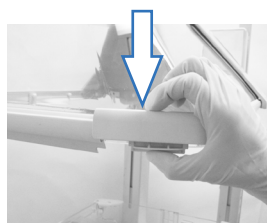

- e. Make sure that all red/orange warning indicators have been covered. Check each canopy seal for secure engagement.



WARNING:

The OmniBed must be properly reassembled per these guidelines. Improper reassembly of the OmniBed may result in unsafe operation of the unit.

11. Screw in the rail locking screws in the oblong slot in each rail to unlock the rails. Refer to Figure 5-1.

Figure 5-20

12. Realign the canopy as described in section 5.6.1.1.
13. Using a 2.5 mm hex key and four screws, reinstall the heater housing cover, securing it to the heater door bracket.
14. Trim and reinstall the soffit:
 - a. Remove the north seal.
 - b. Locate two inside corners of ends of the soffit (6600-1461-500).

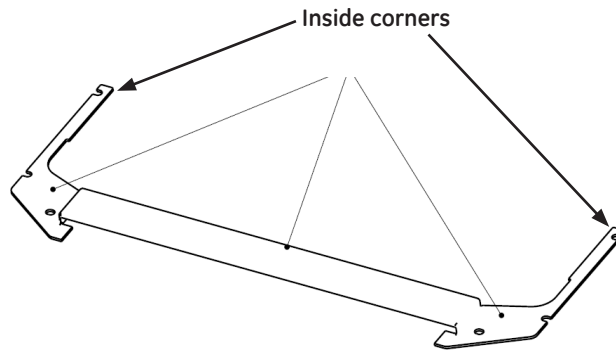

Figure 5-21 Soffit

- c. Mark approximately one eighth inch (3mm) by approximately 45° cut line at the inside corners identified.
- d. Cut corners with scissors or tin snips as marked.

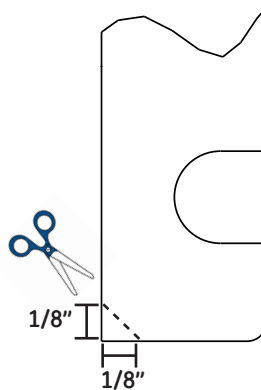

Figure 5-22 Trimming the Soffit

- e. Check for and remove any sharp edges at each of the two corner cuts:

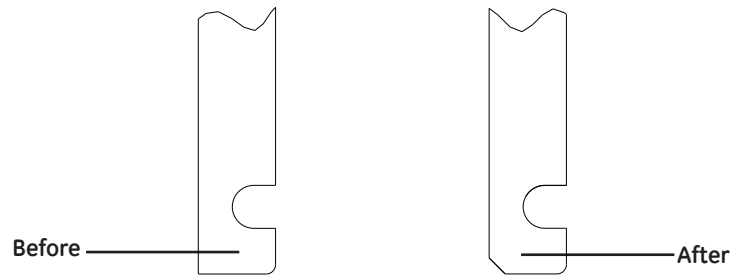
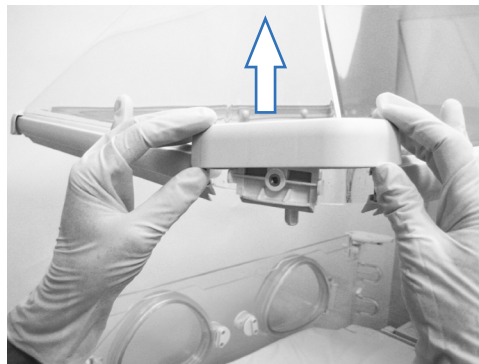

Figure 5-23 Untrimmed and Trimmed Soffit

- f. Reinstall the soffit using the six arrow clips.
 - g. Reinstall north seal.
15. Make sure that all seals can be easily removed:

- a. Lift and unsnap the corner covers.



- b. Slide the long side seals away from the display and off the guide rails.

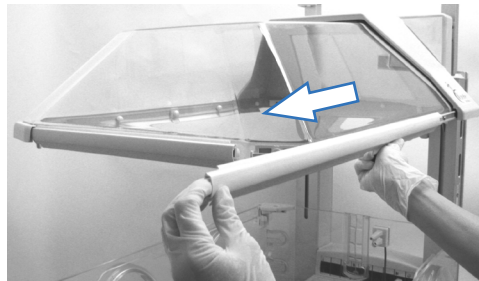

- c. Slide the short south seal to the side.



- d. Unsnap the notched north seal by pulling down the ends.



16. Repeat step 10 to reinstall the seals.

17. Perform the checkout procedure in Chapter 2.



WARNING:

After performing any repair or calibration, always perform service checkout procedures before putting the unit back into service.

5.2.2 Servicing Enhanced Canopy Seals

If your canopy has the enhanced canopy seals, use the following kits to service them:

Kit	Part Number
Corner Cover Replacement	M1208283
Seal Replacement	M1208284
Hardware Replacement	M1208285

5.3 Porthole Door Replacement

Refer to “Figure 6-6 Side Panel (East/West)”.

1. Use a flat edge screwdriver to pry off the hinge cover.
2. Open the door to unload the springs.
3. Slide the hinge pin down, out the hole at the bottom of the hinge.
4. Remove the porthole door.
5. Now the door springs can be accessed along with screws that secure the inside half of the hinge cover.
6. To replace the porthole door, put the door back in place in the open position, install the springs, then slide the hinge pin back in place.
7. Close the door and snap the hinge cover back in place, keeping the thin side of the cover closest to the porthole.

5.4 Right Rail Assembly Repair Procedures



NOTE: The entire rail assembly is available or the individual parts may be replaced. Refer to Chapter 6 for part numbers.

5.4.1 Removing the Right Upright (Motor Side)

Refer to “Figure 5-1 Heater Housing Cover and Soffit”, “Figure 5-24 Disconnecting Heater Door Cable”, “Figure 5-25 Upright Decorative Strips, End Caps, and Wire Covers”, “Figure 5-26 Removing the Lift Motor”, “Figure 5-27 Display Module Disassembly”, and “Figure 5-34 Re-attaching the Upright”.

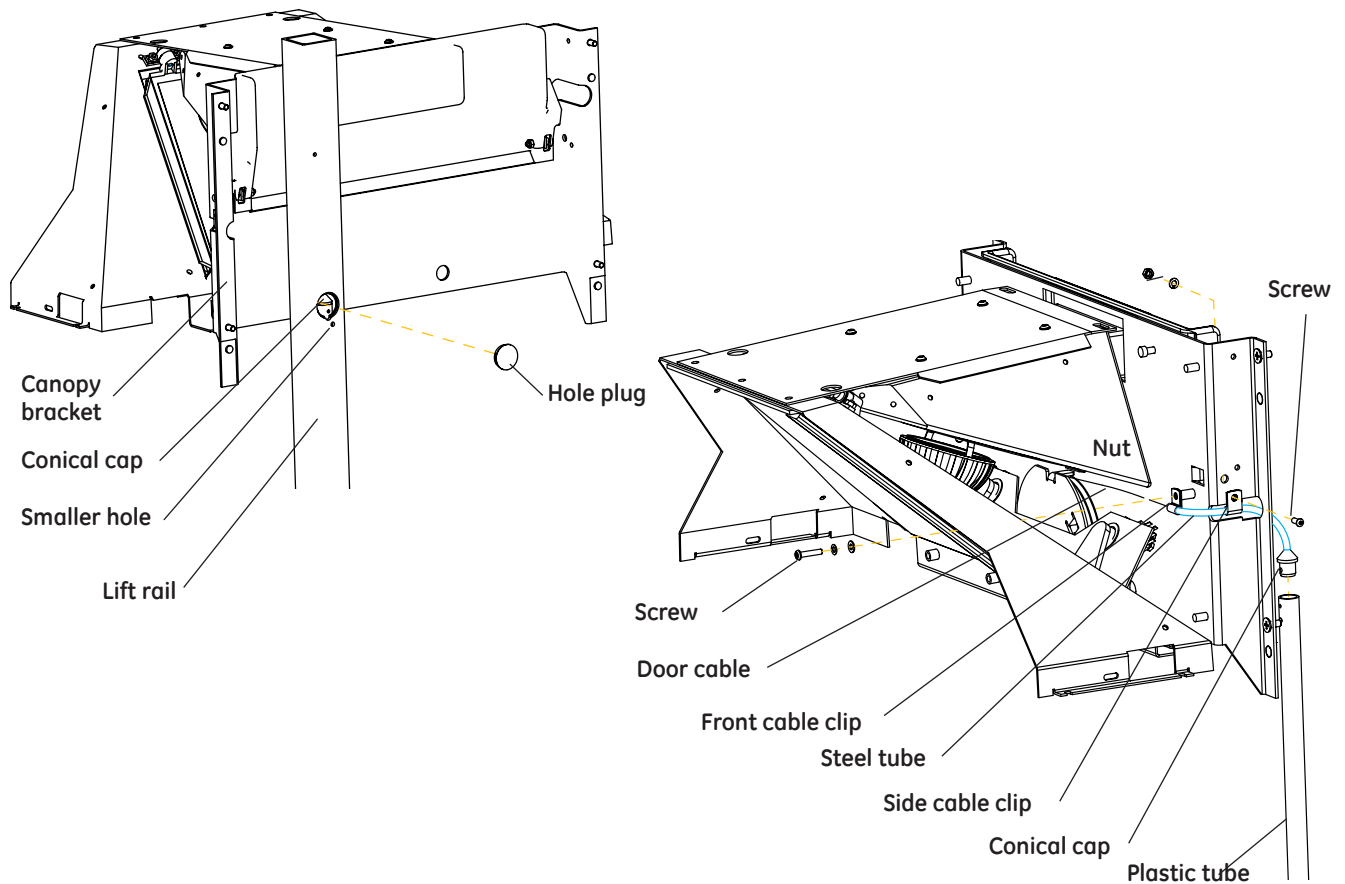

Figure 5-24 Disconnecting Heater Door Cable

1. Lock the rails in the intermediate position by raising the canopy then slowly lowering it until the rail locking screws align with the horizontal oblong holes in the rails. Lock both rails by turning the screws CCW (4mm hex key) until they lock the rails in place. Switch off the unit and disconnect the power cord.
2. Using a small straight blade screwdriver, remove the 6 arrow clips that secure the soffit beneath the rear of the canopy and remove the soffit.
3. Using a 2.5 mm hex key, remove the 4 screws that secure the heater housing cover to the heater door bracket and remove the cover.
4. Remove the right inside cover by removing the 2 screws and nuts (2mm hex key, 5.5 mm wrench) that secure it around the door cable.
5. Remove the steel tube that routes the door cable into the lift rail. Use a 3mm hex key to remove the screw in the front cable clip. Use a 2.5 mm hex key and 7 mm wrench to remove the screw and nut in the side cable clip.
6. Disconnect the heater door cable. The cable end is accessed through the two holes on the back of the lift rail. First pry off the hole plug, then rotate the plastic tube so the hex head screw securing the conical cap faces the rear. Push a small hex key or screwdriver through the small lower hole in the rail, through the lower hole in the plastic tube inside the lift rail, and back through the rail on the other side of the tube to

hold the tube in place. Insert a 2 mm hex key through the larger hole to partially back out the screw that fastens the conical cap to the plastic tube. Pull the cap out of the rail. Pull out the key in the tube hole and let the tube drop down in the upright.

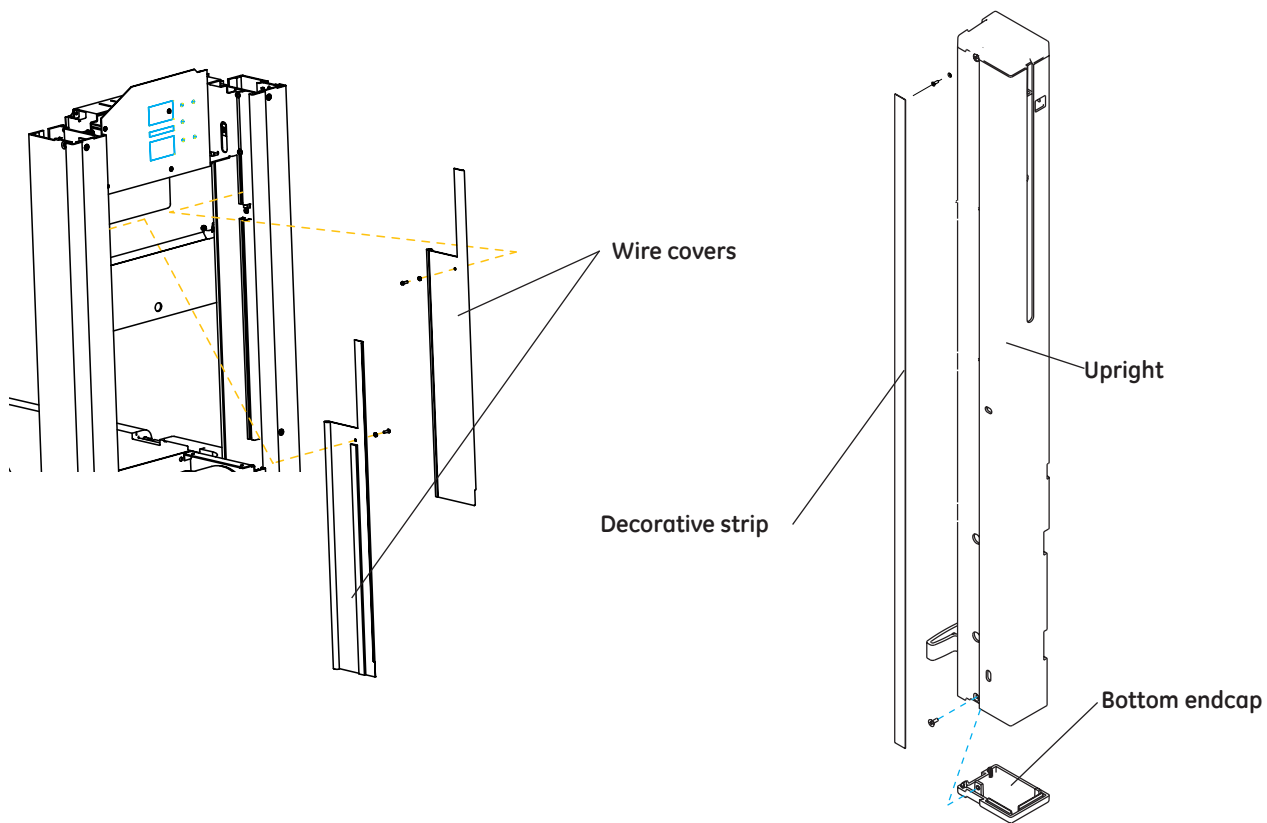

Figure 5-25 Upright Decorative Strips, End Caps, and Wire Covers

7. Remove the two flat head screws (3mm hex key) that hold the canopy bracket to the lift rail.
8. Use a 2.5 mm hex key to loosen the 2 screws in the keyhole slots and remove the 6 remaining screws that secure the controller cover, then remove the cover.
9. Slide the decorative strip up about $\frac{1}{2}$ " in the groove on the outside of the upright to access hardware that secures the lower end cap. You may wish to use a piece of tape to grip the strip. Use a 2.5 mm hex key to remove the screw, then remove the cap. (On units equipped with the Servo Oxygen option, refer to the "5.14.5 Endcap Safety Valve" section for instructions on removing the endcap manifold.) Slide the decorative strip down to access the screw that secures the upper end cap and remove the screw, countersunk washer, and decorative strip. The upper end cap can now be removed by lifting the center cap up out of the lift rail, pushing the exhaust door back, then sliding the outside end cap up and past the spring.

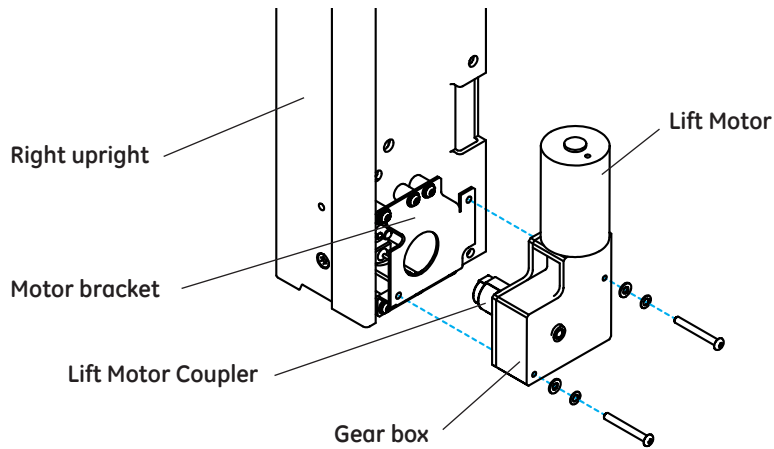
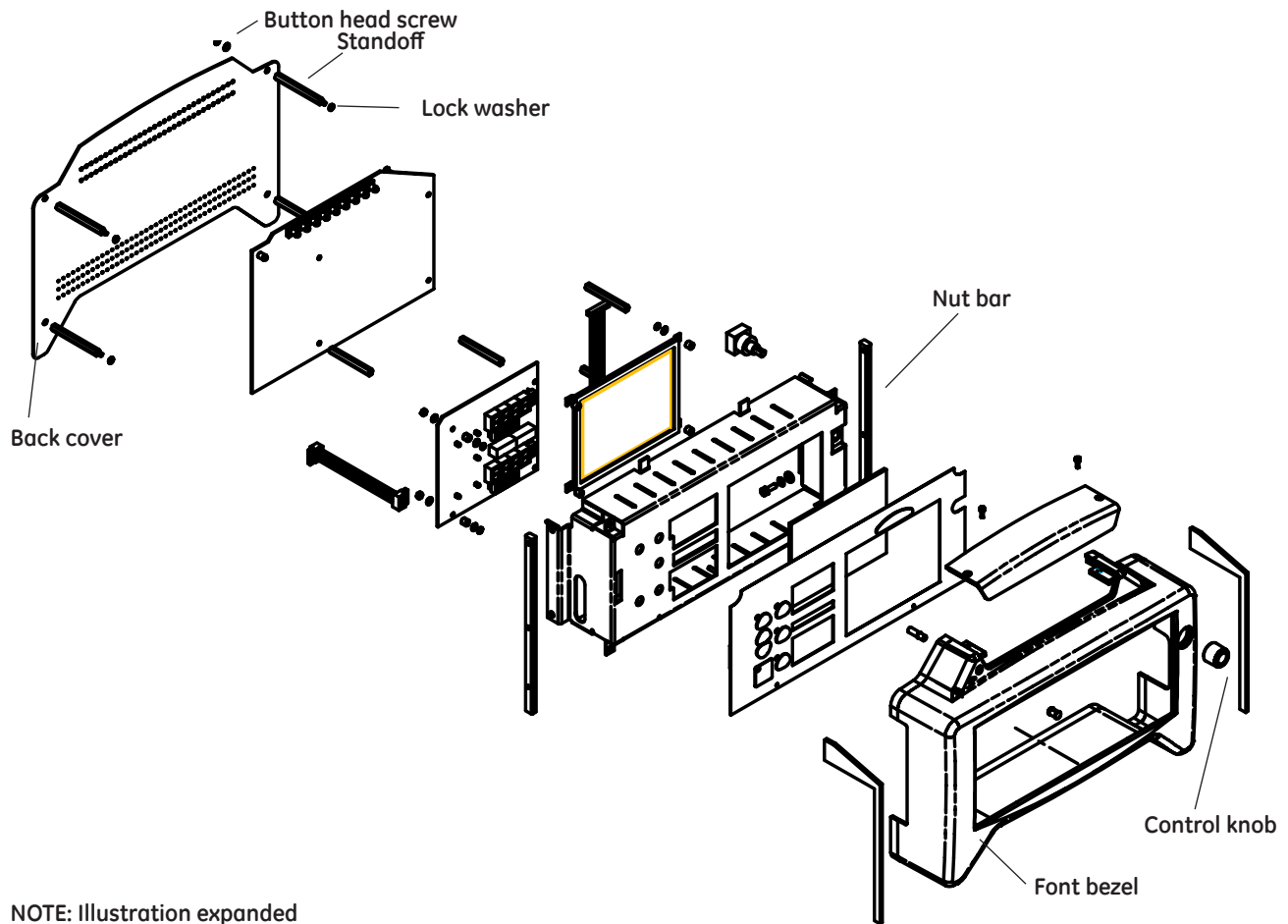

Figure 5-26 Removing the Lift Motor



NOTE: Illustration expanded for clarity.

Figure 5-27 Display Module Disassembly

10. Using a 2mm hex key, remove the 4 button head socket screws and lock washers that secure the back cover to the display module and remove the panel.
11. Remove the control knob from the front of the display by pulling it straight off its shaft.

12. Remove the four standoffs and lock washers (6mm wrench) that held the back cover then remove the front bezel of the display module.
13. Using a 2mm hex key, remove the screw that secures the wire cover to the side of the upright.
14. To remove the wire cover, slide the wire cover up about ½", and then pull it straight back by grasping its back edge.
15. Using a 3mm hex key, remove the 2 screws that secure the display module to the nut bar and pull the nut bar up and out of the upright. Using a 3mm hex key, remove the screw that attaches the ground wire. Be careful not to drop the star washers down into the rail.
16. Remove the screws that secure the connection panel (2.5 mm hex key) at the bottom of the electrical enclosure. Remove the two screws (2.5 mm or 3mm hex key) that secure the canopy motor/gear box to its mounting plate and remove the motor/gear box.
17. While holding on to the lift rail with one hand, use a 4 mm hex key to tighten (CW) the intermediate stop set screw until the screw bottoms out and the inner rail is free, then carefully let the lift rail extend to its full height, releasing spring tension. It may be necessary to pull gently on the canopy to free the standoffs from the rail.
18. Hold on to the upright, and using a 4mm hex key, remove the 2 screws in the holes in the lower side of the upright . Remove the entire upright assembly.

You can disconnect the electrical connector and ground to completely remove the upright or, if you wish, there is enough slack in the wiring to allow you to work on the upright on a table or bench close to the unit without disconnecting the electrical or ground connection. Refer to section 5.4.3 for right rail internal repairs and section 5.4.4 for reassembling the right upright.

5.4.2 Removing the Left Upright

Refer to "Figure 5-1 Heater Housing Cover and Soffit" and "Figure 5-25 Upright Decorative Strips, End Caps, and Wire Covers".



1. Lock the rails in the intermediate position by raising the canopy then slowly lowering it until the rail locking screws align with the horizontal oblong holes in the rails. Lock both rails by turning the screws CCW (4mm hex key) until they lock the rails in place. Power down the unit and unplug it from the power outlet.
2. Using a small straight blade screwdriver, remove the 6 arrow clips that secure the soffit beneath the rear of the canopy (refer to Figure 5-1) and remove the soffit.
3. Using a 2.5 mm hex key, remove the 4 screws and washers that secure the heater housing cover to the heater door bracket and remove the cover.

4. Remove the left inside cover by removing the 2 screws and nuts (2mm hex key, 5.5 mm wrench) that secure it around the electrical cables.
5. Remove the two flat head screws (3mm hex key) that hold the canopy bracket to the lift rail.
6. Disconnect the two electrical connectors to the heater housing and feed them out of the slot in the canopy bracket so they do not catch when the rail tension is released.
7. Loosen the 2 screws in the keyhole slots and remove the 6 remaining screws that secure the controller cover, then remove the cover.
8. Slide the decorative strip up about ½" in the groove on the outside of the upright to access the screw that secures the lower upright end cap. Use a 2.5 mm hex key to remove the screw, then remove the cap. Slide the decorative strip down to access the screw that secures the upper upright end cap and remove the screw and decorative strip. The top end cap can now be removed by lifting the center cap up out of the extrusion then sliding the outside end cap up and past the spring.
9. Using a 2mm hex key, remove the 4 button head socket screws and split ring washers that secure the back cover to the display module and remove the cover.
10. Remove the control knob from the front of the display by pulling it straight off its shaft.
11. Remove the four standoffs and lock washers (6mm wrench) that held the back cover then remove the front bezel of the display module.
12. Using a 2mm hex key, remove the screw that secures the wire cover to the inside of the upright.
13. To remove the wire cover, slide the wire cover up about ½", and then pull it straight back by grasping its back edge.
14. Using a 3mm hex key, remove the 2 screws that secure the display module to the nut bar and pull the nut bar up and out of the upright. Using a 3mm hex key, remove the screw that attaches the ground wire. Be careful not to drop the star washers down into the rail.
15. While holding on to the lift rail with one hand, tighten (CW) the intermediate stop set screw until the inner rail is free, then carefully let the lift rail extend to its full height, releasing spring tension. It may be necessary to pull gently on the canopy to free the standoffs from the rail.
16. Hold on to the upright, and using a 4mm hex key, remove the 2 screws in the holes in the lower side of the upright. Remove the entire upright assembly.

You can disconnect the electrical connector and ground to completely remove the upright or, if you wish, there is enough slack in the wiring to allow you to work on the upright on a table or bench close to the unit without disconnecting the electrical or ground connection. Refer to section 5.5 for left rail internal repairs and section 5.5.4 for reassembling the left upright.

5.4.3 Right Rail Internal Repairs

5.4.3.1 Removing the Inner Rail Assembly

Refer to “Figure 5-26 Removing the Lift Motor”, “Figure 5-28 Right Upright Disassembly”, and “Figure 5-44 Heater Door Cable Adjustment”.

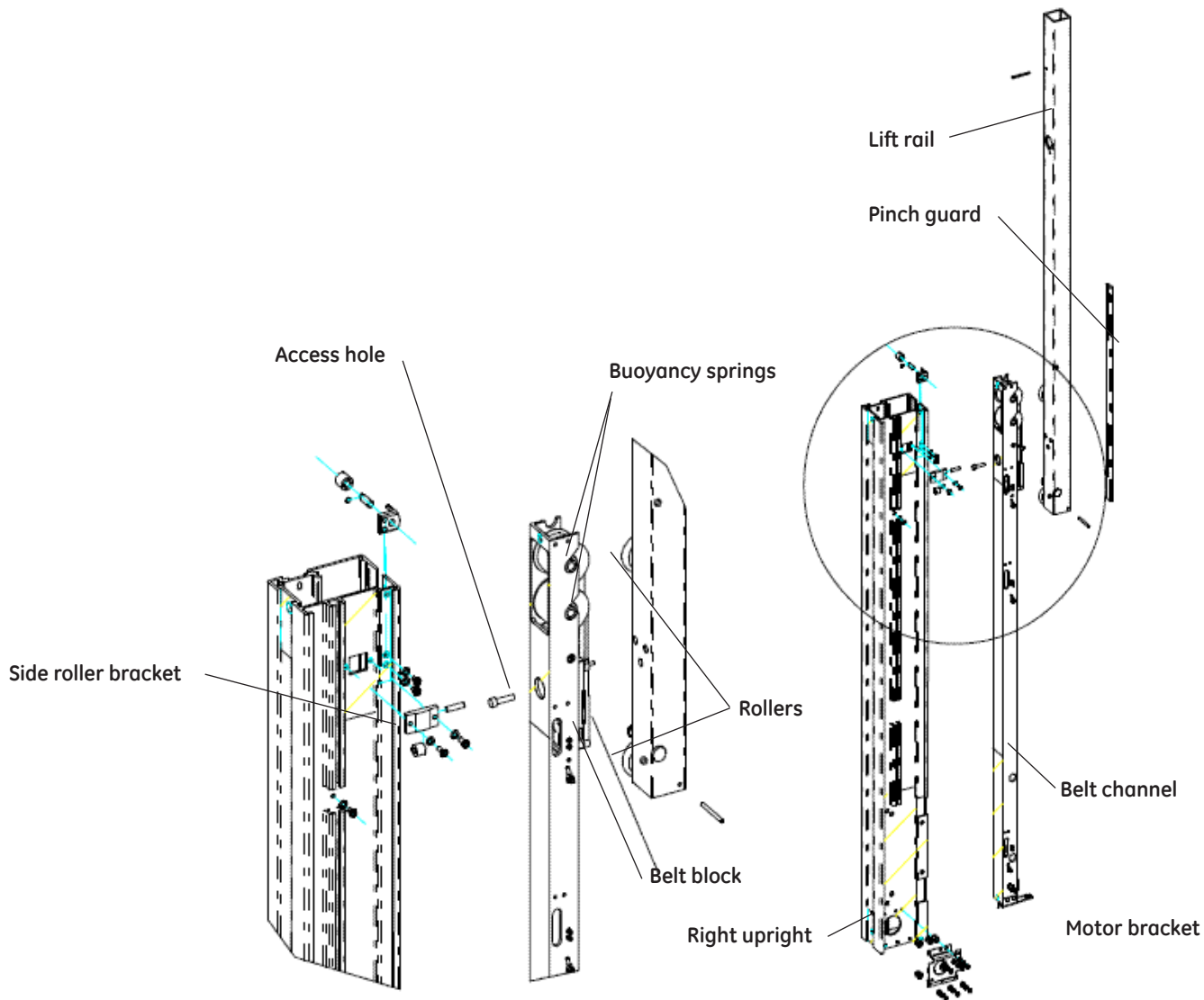

Figure 5-28 Right Upright Disassembly

1. Using a 2.5 mm hex key, remove the 2 screws located at either end of the upright in the rear dovetails that secure belt channel to the inside of the upright. Using a 3mm hex key, remove the side roller bracket. Remove the lift motor coupler components if still attached to the rail assembly. Pull the entire rail assembly up out of the upright.
2. Remove the pinch guard by sliding it up then pulling it off.

- Remove the nut and washers at the bottom of the belt channel that secure the heater door opening rod to the bracket and remove the assembly.

5.4.3.2 Replacing Rollers and Tension Springs

Refer to "Figure 5-29 Rollers and Tensioning Spring".

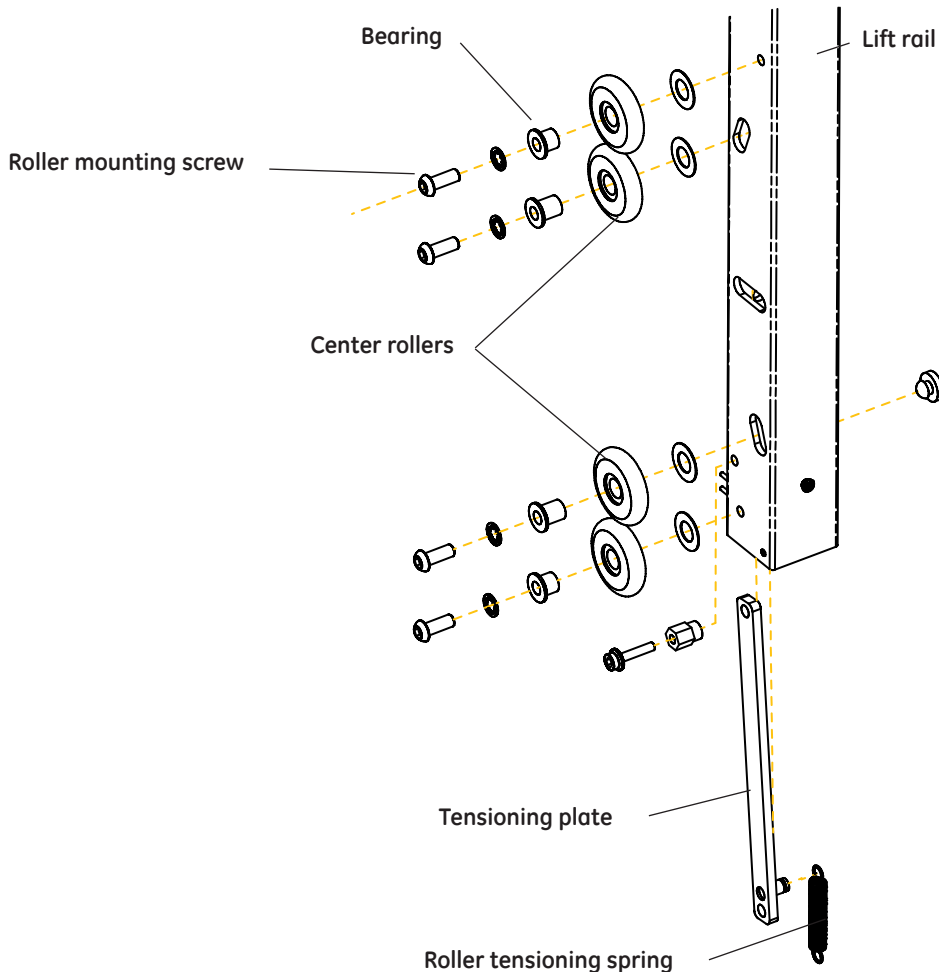

Figure 5-29 Rollers and Tensioning Spring

- The rollers can be removed one at a time by removing the screw (4mm hex key) at their hub and pulling off the roller and bearing. When reinstalling, torque the screws to 45 in. lbs (reference).
- To replace the roller tensioning spring, first use needle nose pliers to pull the tension spring off the roll pin at the end of the lift rail. Then take off the 2 center rollers and slide the tensioning plate out of the lift rail. Remove the old spring.
- Reinstall the 2 center rollers. Use a hex key in the center access slot to lift the tensioning plate up so that you can screw the rollers into the holes in the plate. Torque rollers screws to 45 inch lbs (reference).
- Using pliers, pull the tensioning spring up onto the roll pin at the end of the rail.

5.4.3.3 Separating the Lift Rail from the Belt Channel

Refer to "Figure 5-28 Right Upright Disassembly".

1. If you can access the screw head through the access hole in the lift rail go to step 2. If you can not access the screw, push the lift rail and the belt channel together and lift the belt block up past the roll pin so you can see the screw head through the access hole in the lift rail.
2. Remove the screw that secures the lift rail and the belt channel together (this will require either a 3 or 4mm hex key).

5.4.3.4 Replacing the Rail Drive Belt

Refer to "Figure 5-30 Replacing the Drive Belt".

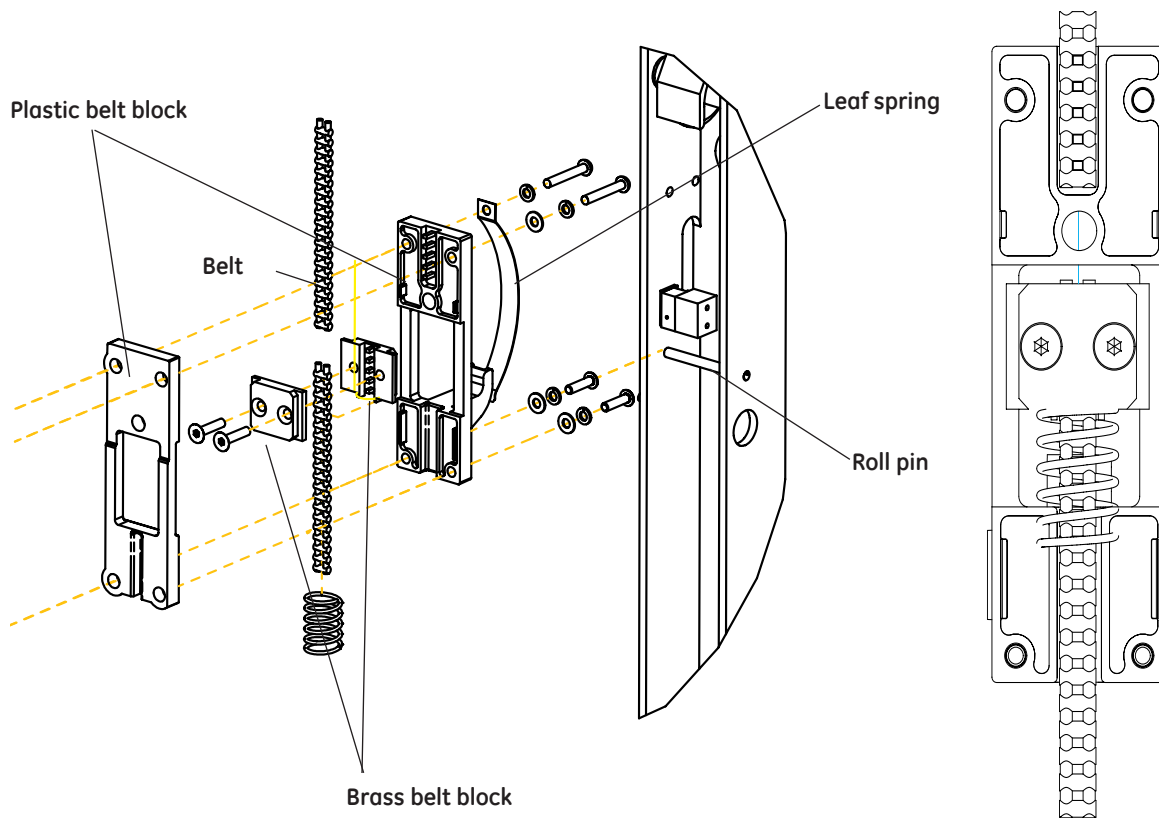

Figure 5-30 Replacing the Drive Belt

1. Using a 5.5 mm wrench, remove the Nylok nuts that secure the springs coil to the plastic belt block. The springs will roll back around their spools.
2. Using a 2mm hex key, remove the 2 screws that secure lower belt guard, remove the guard and run the belt off the bottom sprocket.
3. Using a 2mm hex key, remove the 4 screws (one in each corner) that hold the halves of the plastic belt block together.

4. Using a 2mm hex key, remove the 2 screws in the brass belt-tensioning block. Note that one link protrudes from the brass belt block.
5. Remove and replace the rail drive belt.

NOTE: The replacement rail drive belt is provided precut to the correct length.

5.4.3.5 Replacing the Rail Buoyancy Springs

Refer to “Figure 5-31 Replacing the Rail Buoyancy Springs”.

1. Using a 5.5 mm wrench, remove the Nylok nuts that secure the spring to the plastic belt block. The springs will roll back around their spools.
2. The spools slide out of their mounting slots. To reinstall the spools, assemble each of the spools by wedging them into the rail with the plastic washers at either end of each spool, then slide all the assemble spools into their mounting slots at the same time. Lubricate the spring spools by placing a drop of Lubriplate where the spool hub seats in the slot.

NOTE: Replace all the buoyancy springs in an upright at the same time.

NOTE: When reassembling the rails, be sure the leaf spring is on top of the micro switch to prevent the switch from breaking off.

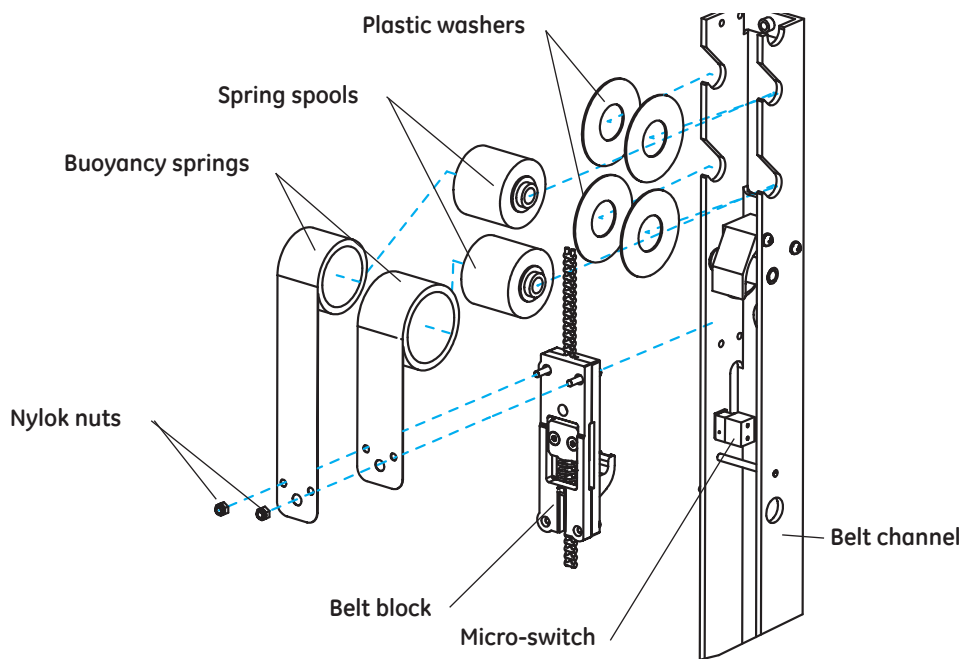

Figure 5-31 Replacing the Rail Buoyancy Springs

5.4.3.6 Replacing the Slip Clutch or Motor Roll Pin

Refer to “Figure 6-19 Belt Channel - 2 (Lift Motor Side)”.

1. After removing the right rail, use a punch that is smaller than .090 to drive out the motor pin (item 18 for Figure 6-19).
2. To remove the slip clutch (item 4), tap out the axle (item 2 for Figure 6-19).

5.4.4 Reassembling the Right Upright

Refer to “Figure 5-25 Upright Decorative Strips, End Caps, and Wire Covers”, “Figure 5-28 Right Upright Disassembly”, “Figure 5-34 Re-attaching the Upright”, and “Figure 5-44 Heater Door Cable Adjustment”.

1. To reassemble replace the screw that secures the lift rail to the belt channel. If the belt block is not already hooked on the roll pin, then push the lift rail and belt channel together so that the buoyancy springs uncoil about 3 inches and the hook on the belt block can ride up over the roll pin in the belt channel.
2. Reinstall the pinch guard. Be sure to orient the pinch guard with the holes in the keyhole slots at the bottom of the rail.
3. Slide the assembly back into the upright, reinstall the screws that secure it to the belt channel and reinstall the side roller bracket. To make sure it is properly seated in its tracks, move the rail assembly through its full range of travel to make sure it does not hang-up or bind before reattaching the upright to the unit. Reinstall the 2 pieces of the motor coupler that fit on the shaft at the base of the upright that mate with the coupler piece on the gearbox shaft.
4. To assist in reattaching the upright to the unit, there are four mounting studs on the bracket casting that mate with four holes in the upright. Place the upright on the studs. Be sure the canopy bracket is in front of the upright. Be careful not to pinch any wires between the unit and the upright.
5. Secure the upright to the unit by reinstalling the 2 screws in the holes inside the upright. Pull any excess wiring slack in the upright channels into the electrical enclosure. Be careful not to drop the screws into the upright.
6. Push the lift rail down into the upright until the rail locking screws align with the horizontal oblong holes in the rail. Lock the rail by turning the screws CCW (4 mm hex key) until they lock the inner rail in place. Install the two flat head screws that attach the canopy bracket to the lift rail.
7. Attach ground wire to rail. Fasten the display module to the upright with the two screws and nut bar removed earlier.
8. Reinstall the wire cover. Take care to route the wires in the upright channels and not to pinch them with the cover when securing with the screw.
9. Reinstall the front bezel of the display module and secure with the 4 standoffs and lock washers. Push the control knob back onto its shaft.

10. Fasten the back panel to the display module with its 4 mounting screws.
11. Raise the elevating base to the highest position.
12. Fish a wire or string down through the lift rail and hook it to the upper hole in the tube on the door opening assembly, then pull the tube up from the bottom of the lift rail until the lower hole in the tube lines up with the small hole in the back of the lift rail. Push a hex key through the smaller hole in the lift rail into the lower hole in the tube to hold the tube in place. Remove the wire. You may wish to tape the hex key in place so that it cannot fall out during assembly.
13. Reconnect the heater door cable. Push the conical cap back through the hole in the front of the lift rail. Reconnect the conical cap to the plastic tube by tightening the screw. Do not over-tighten the screw or you may damage the plastic tube. Reinstall the access hole cover.
14. Secure the steel cable routing tube back in position with its 2 mounting screws.
15. Attach the door cable assembly to the bracket at the bottom upright. Position the top nut and flat washer so the bottom of the flat washer is in the middle of the threads. Slide the threaded heater door opening rod through the bracket, then install the flat washer, lock washer, and nut (8mm wrench).
16. Use a straight blade screwdriver in the slot at the cable rod's end to hold the rod and use the wrench to tighten the bottom nut.
17. Install the upper end cap.
18. Slide the decorative strip up and install the bottom end cap.
19. Reinstall the right inside cover around the door cable with the 2 nuts and screws removed earlier.
20. Reinstall the heater housing cover and canopy soffit.
21. Release the intermediate rail locks by tightening the rail locking screws so the screw heads disengage from the horizontal oblong holes in the uprights.
22. Reinstall the lift motor/gear box. In order to get the splines on the motor coupler to line up you may need to push the lift rail into the upright to rotate the rail side coupler. Then reattach the motor/gear box to its mounting plate with the 2 screws removed earlier.
23. Reinstall the connection panel at the bottom of the electrical enclosure. Fasten the controller cover to the back of the enclosure.

5.5 Left Rail Internal Repairs

5.5.1 Removing the Inner Rail Assembly

Refer to "Figure 5-32 Left Inner Rail".

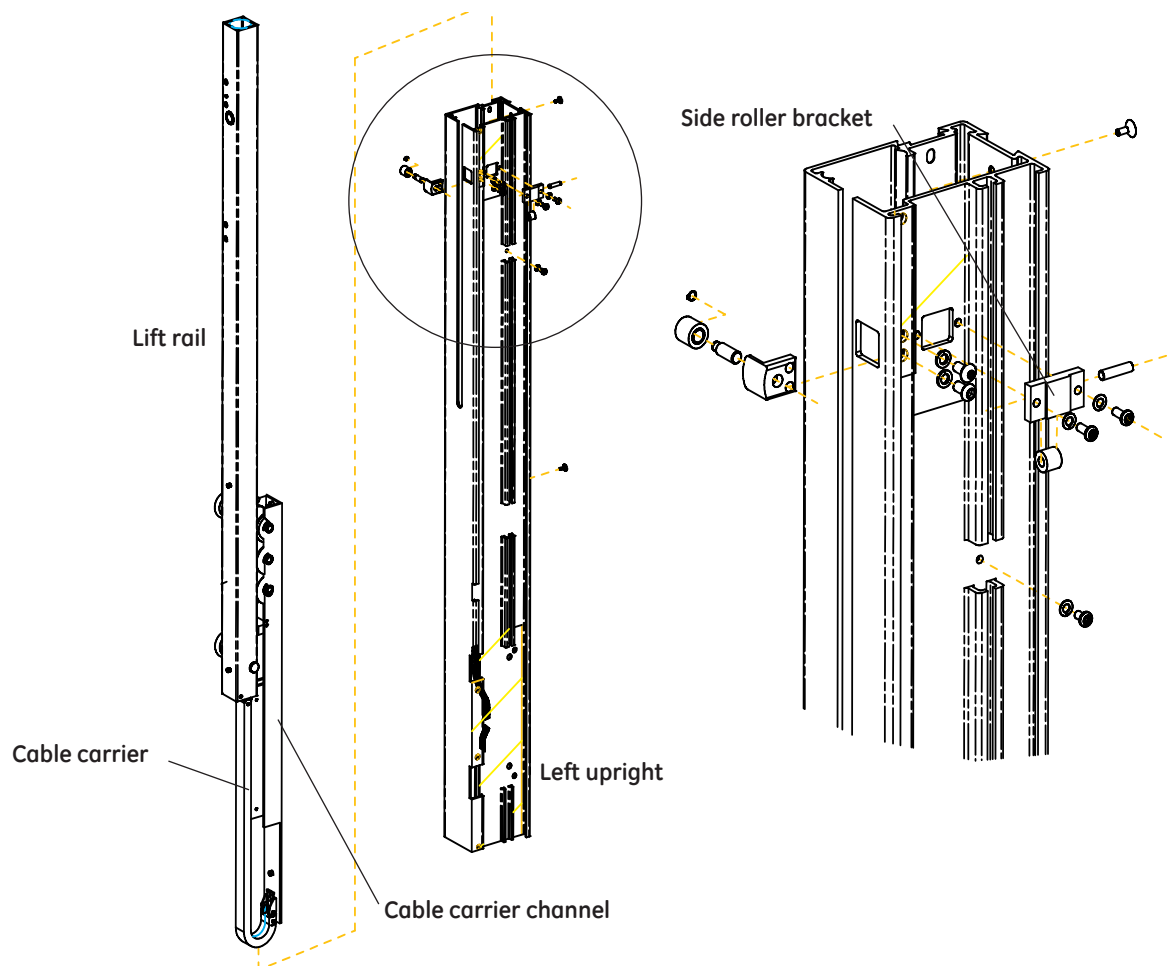

Figure 5-32 Left Inner Rail

1. Using a 2.5 mm hex key, remove the 2 screws in the rear dovetail of the upright that secure the cable carrier channel to the inside of the upright. One screw is located at the top of the upright; the other is half way down. Using a 3mm hex key, remove the side roller bracket. Pull the entire rail assembly out of the upright.
2. Remove the pinch guard by sliding it up then pulling it off.

5.5.2 Replacing the Rail Buoyancy Springs

Refer to "Figure 5-33 Left Rail Springs and Spools".

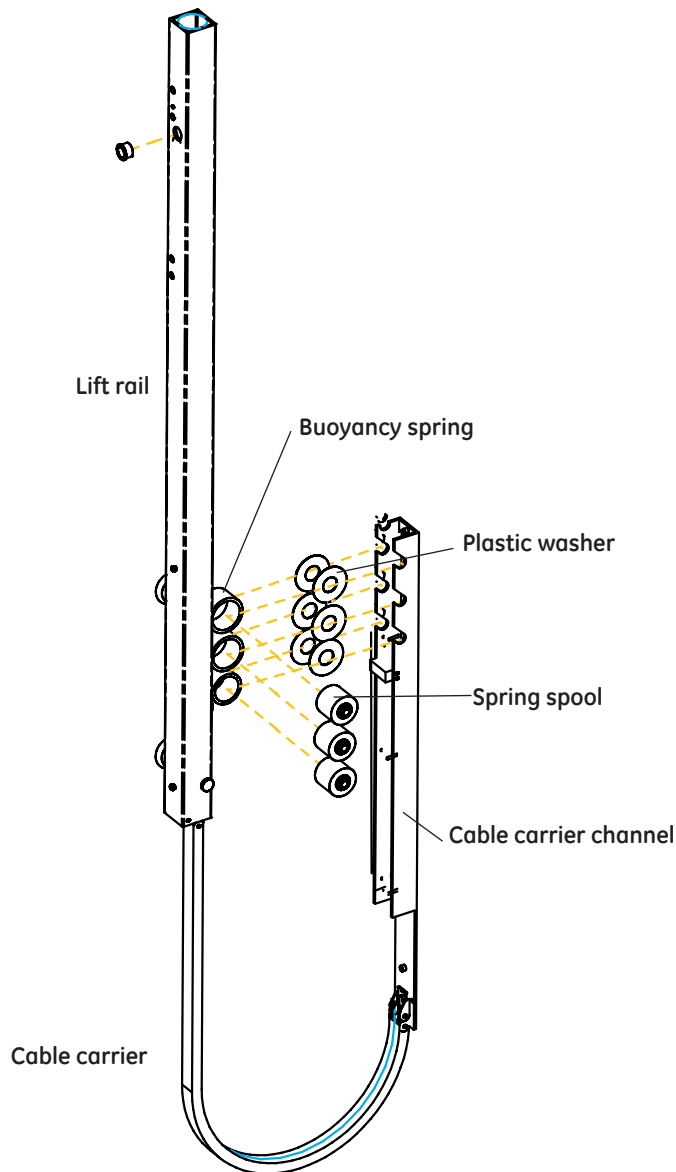

Figure 5-33 Left Rail Springs and Spools

1. Using a 4mm hex key, remove the screw that secures the springs to the lift rail. The springs will roll back around their spools.
2. The spools slide out of their mounting slots. To reinstall the spools, assemble each of the spools by wedging them into the rail with the plastic washers at either side of each spool, then slide all the assembled spools into their mounting slots at the same time. Lubricate the spring spools by placing a drop of Lubriplate where the spool hub seats in the slot.

NOTE: Replace all the buoyancy springs in an upright at the same.

5.5.3 Replacing Rollers, Tension Springs, and Cable Carrier Links

Refer to "Figure 5-29 Rollers and Tensioning Spring".

1. The rollers can be removed one at a time by removing the screw (4mm hex key) at their hub and pulling off the roller and bearing. When reinstalling, torque the screws to 45 in. lbs (reference).
2. To replace the roller tensioning spring, first use pliers to pull the tension spring off the roll pin at the end of the lift rail. Then take off the 2 center rollers and slide the tensioning plate out of the lift rail. Remove the old spring.
3. Reinstall the 2 center rollers. Use a hex key in the center access slot to lift the tensioning plate up so that you can screw the rollers into the holes in the plate. Torque the screws to 45 in. lbs (reference).
4. Using pliers, pull the tensioning spring up onto the roll pin at the end of the rail.
5. Individual links of the flexible cable carrier snap out of the belt by unfolding them from their center. To replace the link that fastens the carrier to the channel, drill out the rivet and replace it with a M3 x 8 screw.

5.5.4 Reassembling the Left Upright

Refer to "Figure 5-25 Upright Decorative Strips, End Caps, and Wire Covers", "Figure 5-32 Left Inner Rail", "Figure 5-33 Left Rail Springs and Spools", and "Figure 5-34 Re-attaching the Upright".

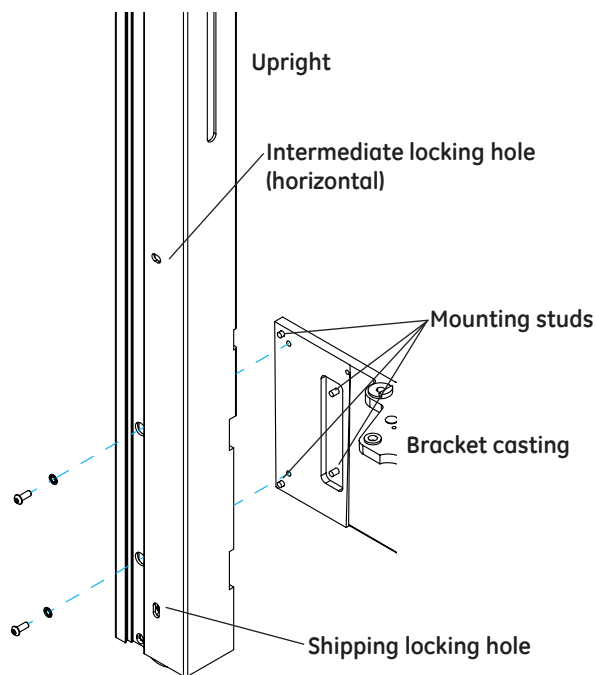

Figure 5-34 Re-attaching the Upright

1. Reinstall the pinch guard. Be sure to orient the pinch guard with the holes in the keyhole slots at the bottom of the rail.

2. Position the lift rail and the cable carrier channel so that the plastic boss is past the metal stop block and the coil springs have a slight tension. Slide the channel and lift rail together so that the last tensioning roller is just entering the upright. Align the screws with the holes. Slide the assembly back into the upright. Using a 3mm hex key, reinstall the side roller bracket. To make sure it is properly seated in its tracks, move the rail assembly through its full range of travel to make sure it does not hang-up or bind before reattaching the upright to the unit.
3. To assist in reattaching the upright to the unit, there are four studs on the bracket casting that mate with four holes in the upright. Place the upright on the studs. Be sure the radiant heater bracket is in front of the upright. Be careful not to pinch any wires between the unit and the upright.
4. Secure the upright to the unit by reinstalling the 2 screws in the holes inside the upright. Pull any excess wiring slack in the upright channels into the electrical enclosure.
5. Push the lift rail down into the upright until the rail locking screws align with the horizontal oblong holes in the rail. Lock the rail by turning the screws CCW (4 mm hex key) until they lock the inner rail in place.
6. Attach ground wire to rail. Fasten the display module to the upright with the two screws and nut bar removed earlier.
7. Reinstall the wire cover. Take care to route the wires in the upright channels and not to pinch them with the cover when securing with the screw.
8. Reinstall the front bezel of the display module and secure with the 4 standoffs and lock washers. Push the control knob back onto its shaft.
9. Fasten the back panel to the display module with its 4 mounting screws.
10. Reinstall the decorative strip and the two end caps.
11. Fasten the controller cover to the back of the enclosure.
12. Attach the canopy bracket to the lift rail with the 2 screws removed earlier.
13. Reconnect the 2 electrical connectors for the radiant heater.
14. Reinstall the left inside cover around the electrical cables with the 2 nuts and screws removed earlier.
15. Reinstall the heater housing cover and canopy soffit.
16. Release the intermediate rail locks by tightening the set screws so that the screw heads disengage from the horizontal oblong holes in the uprights.

5.5.5 Replacement of the Left Upright Heater Wire Harness/Cable Carrier Assembly

The heater wire harness/cable carrier assembly (6600-0710-700) includes both the wire harness and the cable carrier. The end links of the cable carrier are riveted to the lift rail and the cable carrier channel (2 pop rivets at each end). The easiest way to replace the harness is to reuse these end links of the cable carrier. If the end link of the cable carrier is damaged, there are two options:

- Replace the entire left upright assembly (66600-0288-851). (Refer to section 5.4.2)
- Drill out the rivets that secure the broken link to the lift rail or Cable carrier channel. Remove the end link from the new assembly and rivet it in place. Then follow the instructions below. Two rivets are required for each end of the cable.

6600-1160-400 Pop Rivet Stainless Steel, Body Diameter .125", body length .313"

The 3-pin MAT-N-LOK connector for the radiant heater connections must be removed from the old harness using a pin extractor. If a pin extractor is not available, order a new connector when you order the harness. Four cable ties are also required.

6600-1097-603 3 pin Universal MAT-N-LOK connector

6600-0384-400 Cable Tie

5.5.5.1 Removing and Disassembling the Rail

Refer to "Figure 5-33 Left Rail Springs and Spools".

1. Remove the left upright following section 5.4.2.
2. Remove the inner rail assembly following section 5.4.3.1.
3. Remove the 3 buoyancy spring spools from the cable carrier channel. Save the spring spools and plastic washers for reinstallation.

5.5.5.2 Removing the Old Harness Assembly from the Left Rail

For instructions on removing the harness from the cable carrier channel, refer to section 5.5.5.4.

NOTE: Before removing the old harness make note of the wire routing, cable tie orientation and placement, and bushing location. This will assist in installing the replacement harness.

1. Open the first 4 cable guard latches at the left rail end.

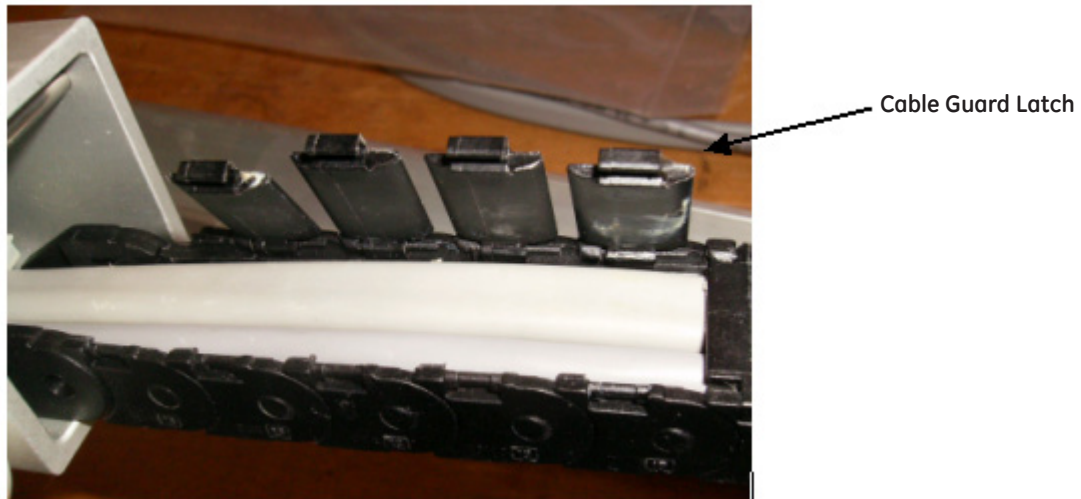

Figure 5-35 Cable Guard Latch

2. Unsnap and remove the end link from the cable carrier.
3. Remove the remaining open links from the cable carrier by unsnapping them from the adjoining link.
4. Carefully cut the cable tie at the end of the left rail (tie secures harness to the carrier).
5. Remove the 3-pin MAT-N-LOK connector (cut wires or extract pins) from the harness on the side of the left rail.

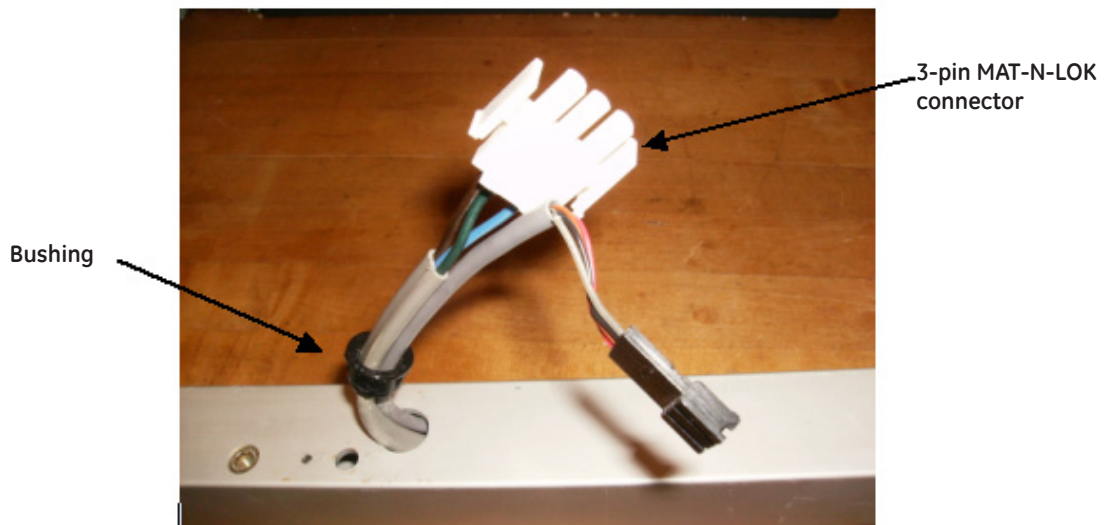

Figure 5-36 3-pin MAT-N-LOK Connector and Bushing

6. Remove the bushing on the side of the left rail.
7. Attach a wire or string to this harness to assist in threading the new cable assembly through the rail.

8. Remove the old harness from the left rail. Be sure to save the bushing for use in installing the new harness.

5.5.5.3 Reinstalling the New Harness on the Left Rail

1. On the left rail end of the replacement harness, mark the location on the harness where the cable tie was located.



Figure 5-37 Cable Tie

2. Remove the cable tie that secures the harness to the carrier.
3. Open the first 4 cable guard latches.
4. Unsnap and remove the end link from the cable carrier.
5. Thread cable through the left rail and out hole on side
6. Pull cable through the rail until the cable mark is in the correct position just inside rail.
7. Reinstall the bushing in the hole on the side of the rail
8. Verify the mark on the cable is still in the correct position and reconnect the cable carrier to the end link riveted to the left rail. Close the other 4 cable guard latches.
9. Reinstall new cable tie to secure the harness to the carrier
10. Reinstall the 3-pin connector.

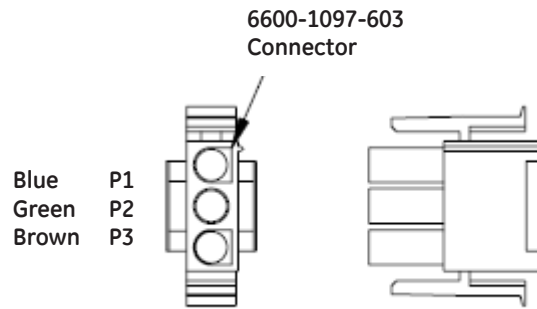

Figure 5-38 Connector Drawing

5.5.5.4 Removing the Old Harness from the Cable Carrier Channel

1. Open the first 4 exposed cable guard latches at the cable carrier channel end.

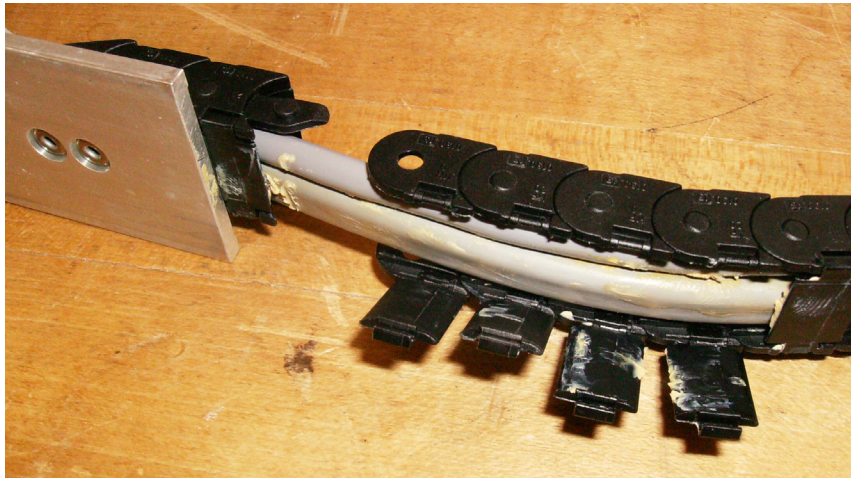

Figure 5-39 Opened Cable Guard Latches

2. Unsnap the links with open covers leaving the end riveted link and 2 additional links on the cable carrier channel.
3. Remove the 4 cable ties securing the harness to the channel. (Make note of routing and orientation).
4. Remove and discard the harness. You may want to save the cable carrier links to use as spares.

5.5.5.5 Installing the New Harness on the Cable Carrier Channel

1. On the replacement harness open the first 4 cable guard latches at the cable carrier channel end.
2. Remove the end link and the 2 adjoining links and set aside.

3. Route harness along the cable carrier channel and loosely install 4 cable ties. Do not tighten until cable is adjusted properly. Be sure to install in same orientation as ties removed earlier.

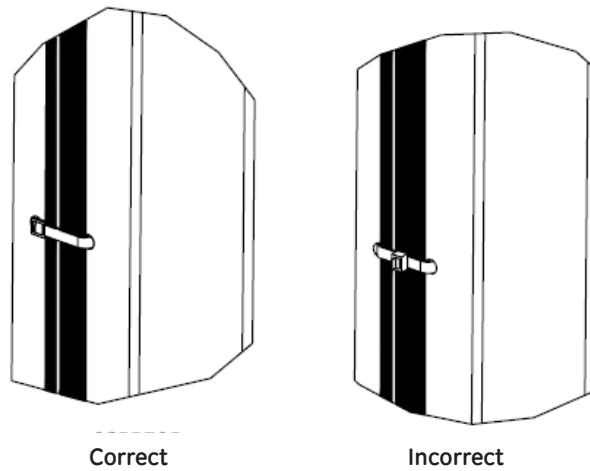

Figure 5-40 Correct and Incorrect Cable Tie Usage

4. Reattach the cable carrier channel to the 3 links riveted to the channel.
5. Close all open cable guard latches.
6. Bring Lift Rail and Cable Carrier Channel together as shown in the following figure.

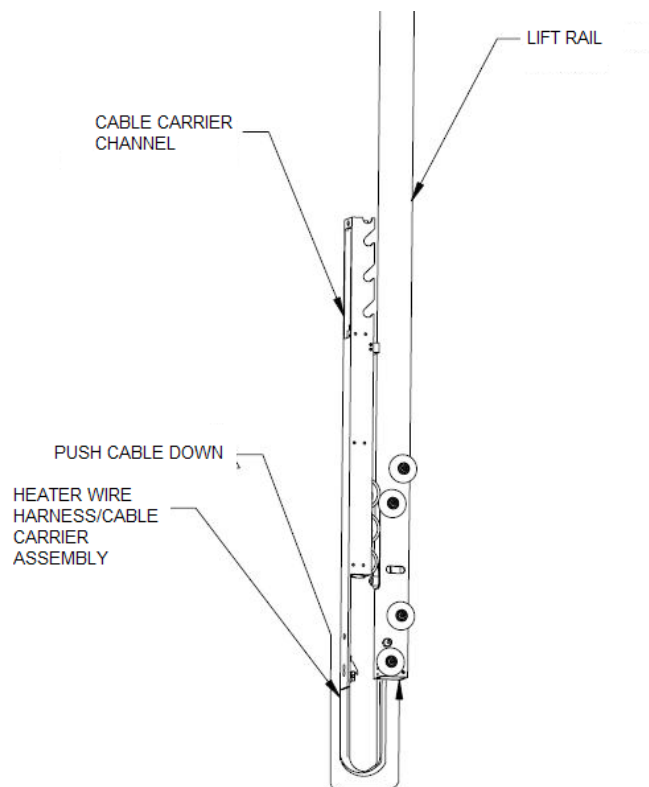

Figure 5-41 Lift Rail and Cable Carrier Channel Together

7. Make sure that the cables within the cable guard are not overlapping.
8. Push the cables downward to orient the cables against the outside edge of the cable carrier. This creates enough slack so the cables are not tight as the rails move up and down.
9. Secure cables to riveted end of cable carrier with new cable tie

5.5.5.6 Reassembly

1. Reassemble the buoyancy spring spools and plastic washers in the springs, then into the cable carrier channel.
2. Reassemble and reinstall the left upright following section 5.5.4.
3. After performing any repair always perform the service checkout before putting the unit back into service.

5.6 Radiant Heater Assembly Repair Procedures



WARNING:

Allow the heater to cool before servicing.

5.6.1 Removing the Canopy/Heater Assembly

Refer to “Figure 5-1 Heater Housing Cover and Soffit”, “Figure 5-5 Canopy, Bracket, and Heater Housing”, “Figure 5-24 Disconnecting Heater Door Cable”, “Figure 5-34 Re-attaching the Upright”, and “Figure 5-42 Canopy Alignment”.

NOTE: It is not necessary to remove the canopy to replace the radiant heater. To replace the radiant heater assembly, perform the instructions in section 5.6.2.

1. Raise the canopy to the intermediate lock position, then lock it in place by loosening the rail locking screws on the outside of both uprights so that their heads engage the holes in the uprights. Shut off the unit and disconnect the power cord.
2. Using a small straight blade screwdriver, remove the 6 arrow clips that secure the soffit beneath the rear of the canopy and remove the soffit.
3. Using a 2.5 mm hex key, remove the 4 screws and washers that secure the heater housing cover to the heater bracket and remove the cover.
4. Disconnect the 2 electrical connections to the heater housing.
5. Remove the right inside cover. Using a 2mm hex key and a 5.5 mm wrench, remove the 2 screws and nuts that secure the right inside cover.

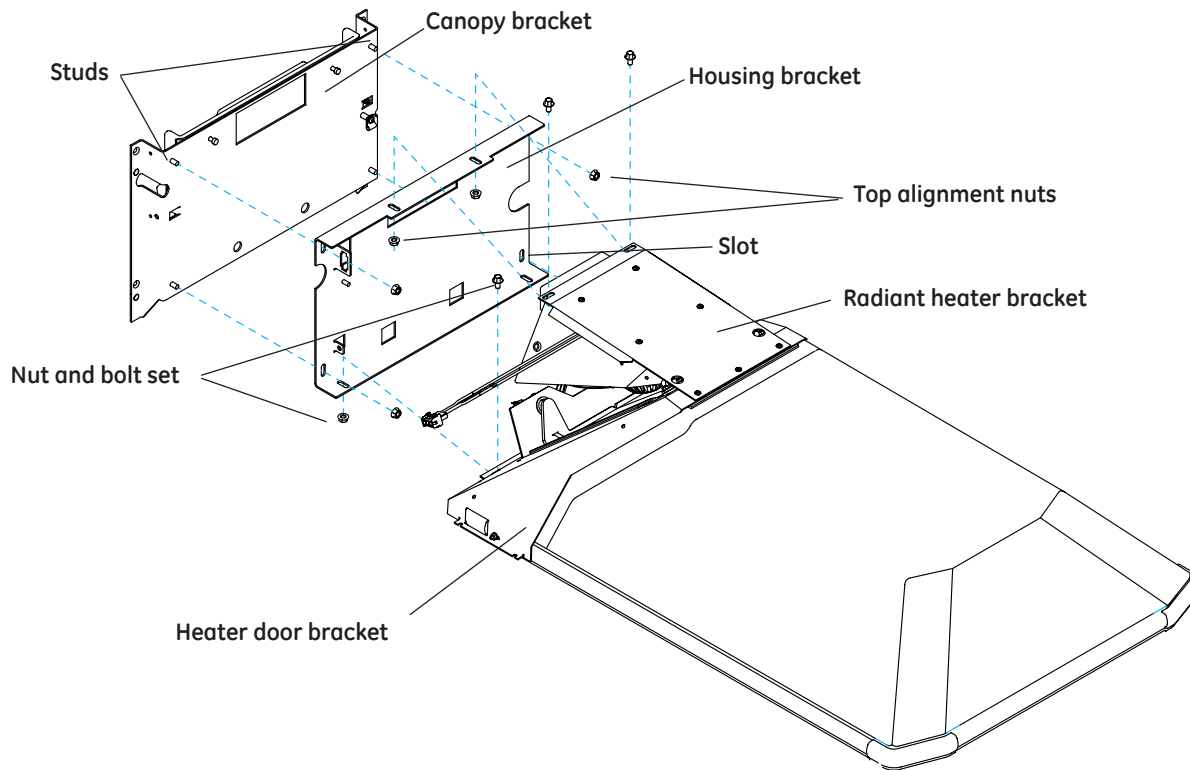

Figure 5-42 Canopy Alignment

6. Remove the steel tube that routes the door cable into the extrusion. Use a 3mm hex key to remove the screw in the front cable clip. Use a 2.5 mm hex key and 7mm wrench to remove the screw and nut in the back cable clip.
7. Disconnect the heater door cable. The cable end is accessed through the two holes on the back of the lift rail. First pry off the hole plug, then rotate the plastic tube so the hex head screw securing the conical cap faces the rear. Push a small hex key or screwdriver through the small lower hole in the rail, through the lower hole in the plastic tube inside the extrusion, and back through the rail on the other side of the tube to hold the tube in place. Insert a 2 mm hex key through the larger hole to loosen the screw that fastens the conical cap to the plastic tube. Pull the cap out of the rail.
8. Using a 10mm wrench remove the 4 nuts on the housing bracket that secure the entire assembly to the uprights. Grasp the canopy with both hands and raise it about ½" until the keyhole disengages. Remove the canopy/heater assembly.

To reinstall the canopy reverse steps. Take care not to pinch the electrical cables.

5.6.1.1 Realigning the Canopy

Refer to “Figure 5-42 Canopy Alignment”.

There are four nuts and four nut-and-bolt sets that adjust canopy alignment. These require a 10 mm wrench and torque to approximately 81 inch-pounds.

1. Loosen all eight black canopy alignment nuts.
2. Manually lift the canopy to its highest adjustment position (so the studs in the canopy bracket are located at the bottom of the slots in the housing bracket). Tighten the top two alignment nuts on the housing bracket.
3. If necessary, plug in the power cord and switch on the unit.
4. Use the canopy lower switch to lower the canopy until it reaches its bottom travel limit switch. This is indicated when the “In Transition” message goes out on the graphic screen.
5. Loosen the top two alignment nuts on the back plate to fully seat the canopy on the side walls. As a starting point, there should be an approximate 0.15 inch gap at each of the canopy corners. One way to shim up the corners, is to place a 2.5 mm hex key or a 3 mm hex key as spacers in either of the north canopy corners and a 4 mm hex key or a 5 mm hex key as spacers at either of the south canopy corners.
6. Retighten the top two alignment nuts on the housing bracket.
7. Tighten the remaining two nuts and four nut-and-bolt sets on the housing bracket.
8. Check alignment by raising and lowering the canopy. If the alignment is not satisfactory, loosen and retighten all eight alignment nuts with corner shims in place. Repeat until alignment is satisfactory.

5.6.2 Replacing the Radiant Heater

Refer to “Figure 5-1 Heater Housing Cover and Soffit” and “Figure 5-43 Radiant Heater Disassembly”.

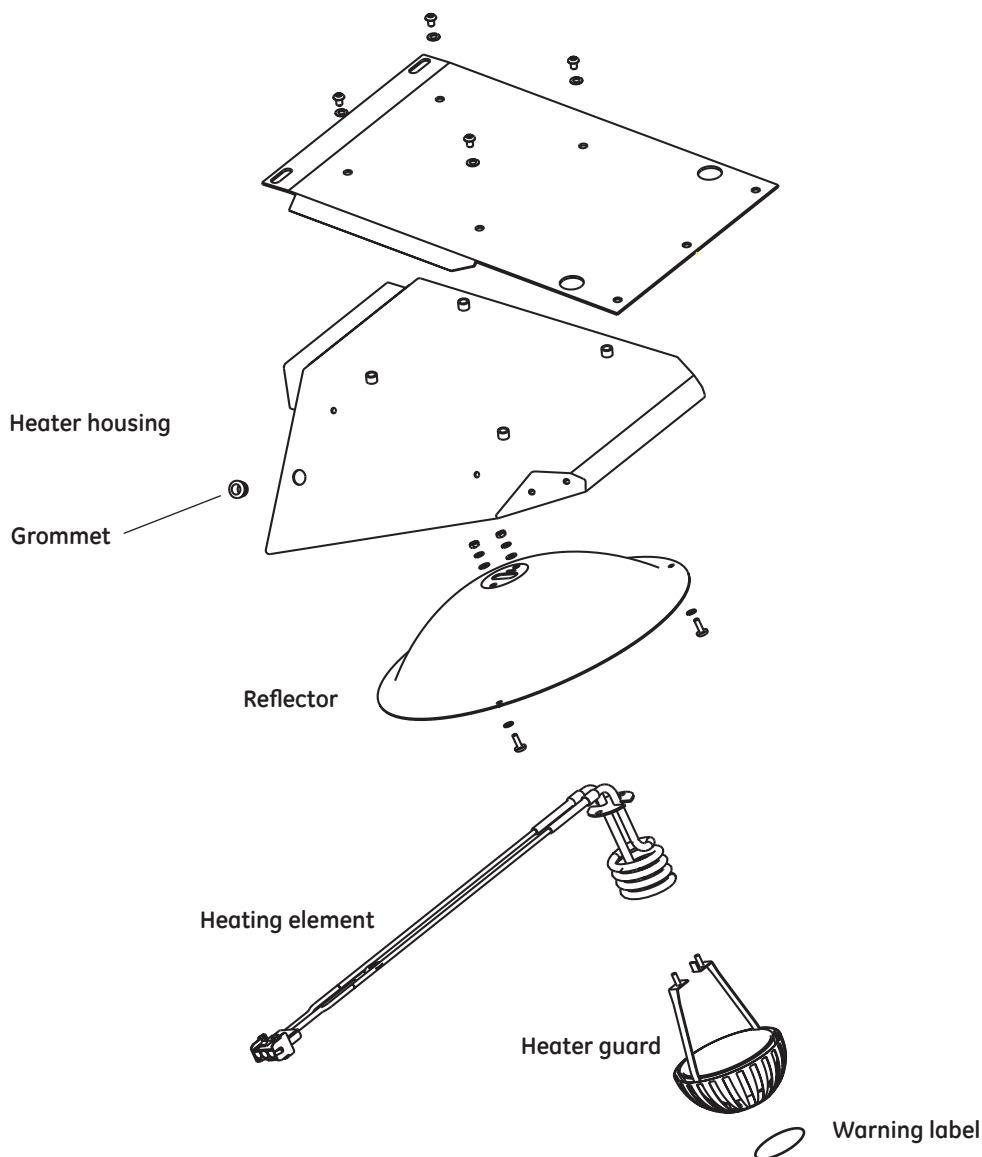

Figure 5-43 Radiant Heater Disassembly

Before replacing the heating element, use an ohmmeter between the pins to determine if the heating element is the failed electrical component. A replacement heater kit includes heating element; heater leads with pins, and the connector and ground wire. You can replace the element with the canopy still assembled to the unit by running the canopy to its top travel limit and lowering the elevating base to its lowest position.

1. Using a small straight blade screwdriver, remove the 6 arrow clips that secure the soffit beneath the rear of the canopy and remove the soffit
2. Remove the 4 screws that secure the heater housing cover to the heater bracket and remove the cover.

3. Using a 8mm wrench, remove the nut and 2 lock washers that secure the ground wire. Cut the wires to the heater, and remove and discard the female half of the connector.
4. Remove the 2 screws and lock washers (2.5 mm hex key) that secure the reflector and remove the heater assembly.
5. Remove the 2 nuts and lock washers (5.5 mm wrench) from the back of the reflector and remove the heating element and heater guard.
6. Install the new heating element and reinstall the guard in the reflector. Thread the wires from the new heating element through the grommet in the heater housing.
7. Use the 2 mounting screws and lock washers to reinstall the reflector.
8. Mount the new female half of the connector in its mounting. Push the pins from the heating element into the connector. Route the ground wire straight up from the ground stud and secure it with the lock washers and nut. Push any slack in the heater wire into the housing.

5.6.3 Heater Door Spool Assembly

Refer to "Figure 5-44 Heater Door Cable Adjustment".

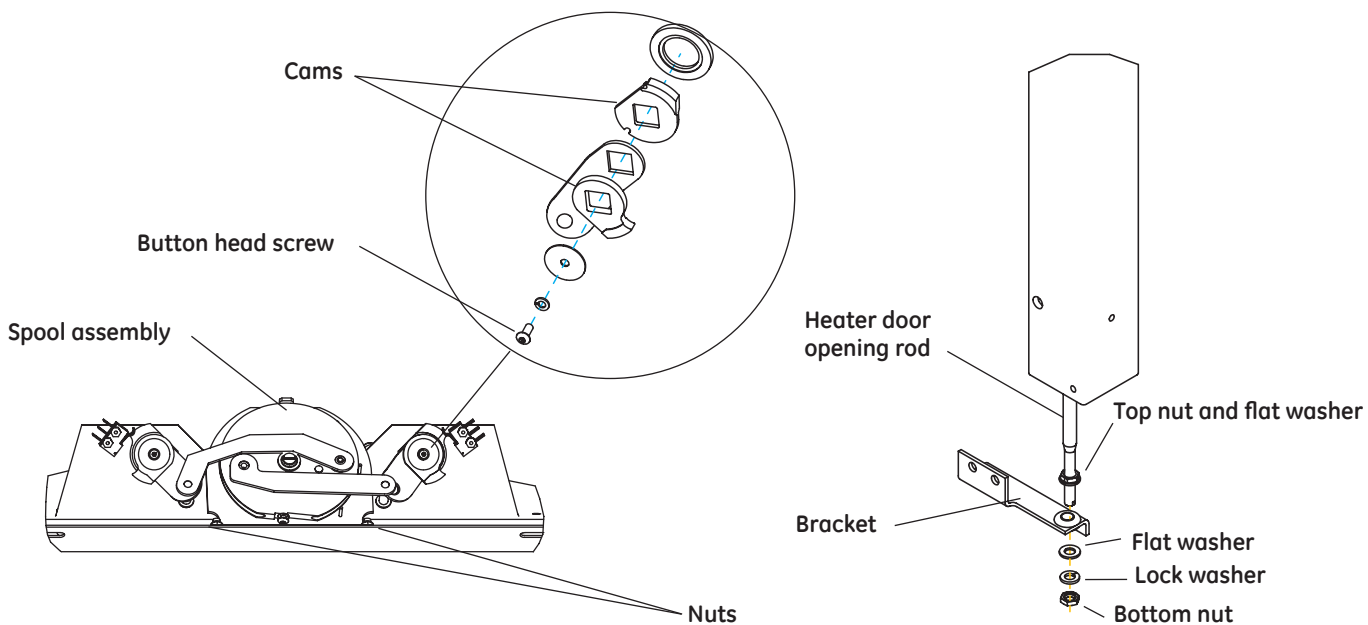
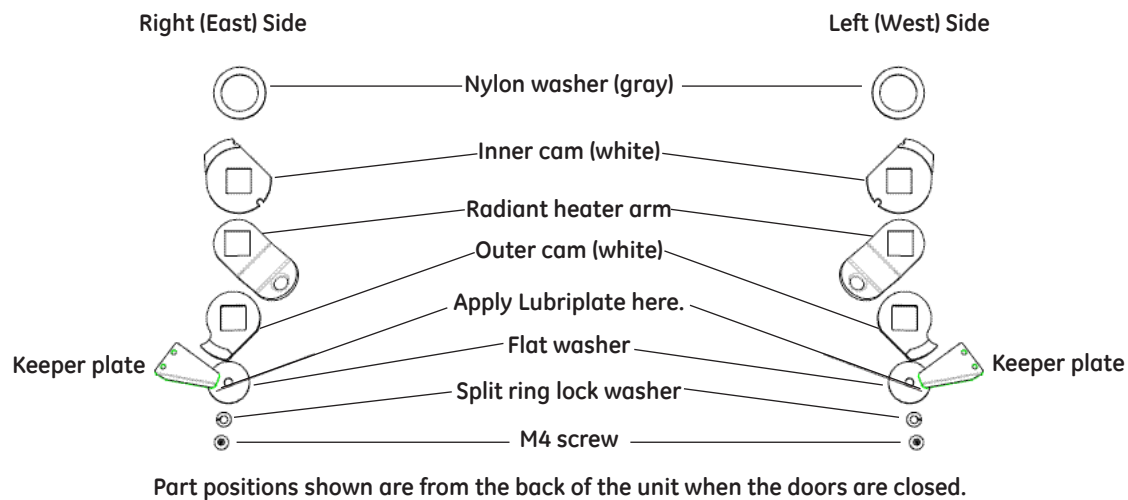

Figure 5-44 Heater Door Cable Adjustment

To access the heater door spool assembly first disassemble the canopy/heater from the unit as described in "Removing the Canopy and Heater Assembly."

1. Remove the housing bracket from the heater assembly.
2. To replace the spool assembly, use a 2.5 mm hex key to remove the button head screw that secures the cams and door links. Then use an 8mm wrench to remove the 2 nuts that hold the spool.

3. To replace the door cable, use a flat screwdriver blade to pry the top tang (12 o'clock position) on the spool assembly and pull the cable off the spool toward you. Use a 2.5 mm hex key to separate the cable from the spool.

5.6.4 Heater Door Cable Adjustment

Refer to "Figure 5-44 Heater Door Cable Adjustment".

1. The bottom end cap on the right side upright should be removed. Position the top nut and flat washer so the bottom of the flat washer is in the middle of the threads. Slide the heater door opening rod through the bracket, then install the flat washer, lock washer, and nut (8mm wrench).
2. Use a straight blade screwdriver in the slot at the cable rod's end to hold the rod and use the wrench to tighten the bottom nut.
3. Turn on the unit and run the canopy to its upper travel limit, and verify that both doors fully open.

5.6.5 Spring Tube Assembly Replacement

For an exploded view of the spring tube assembly, refer to section 6.1.7.

1. Elevate the elevating base to the upper limit of travel.
2. Elevate the canopy to the service position, about halfway up so that the black oxide shipping screw is centered in the horizontal slot, which is about midway up on the outside of the dovetail rail.
3. Turn off the unit and unplug it from the wall.
4. Slide up the decorative strip in the dovetail rail slot to expose lower end cap screw. (A piece of adhesive tape on the decorative strip can help to move it.)
5. Remove the lower end cap.
6. Remove the hole plug from the back of East lift rail. (Refer to "Figure 5-24 Disconnecting Heater Door Cable".)
7. Rotate the spring tube assembly until the setscrew hole and lower securing hole are visible from the access hole in the back of the inner rail. Insert a 2 mm hex wrench through the small hole in the back of the inner rail through the spring tube and back into the rail to temporarily secure the spring tube assembly to the inner rail.
8. Unscrew the setscrew in the door cable conical cap until it is possible to separate the door cable cap from the spring tube. Do not remove the setscrew.
9. Secure a length of string to the cross-hole in the spring tube. The string should be long enough to allow the spring tube to be removed from the bottom of the rail assembly. Firmly secure the other end of the string. This string will be used to lift the new spring tube assembly into place.

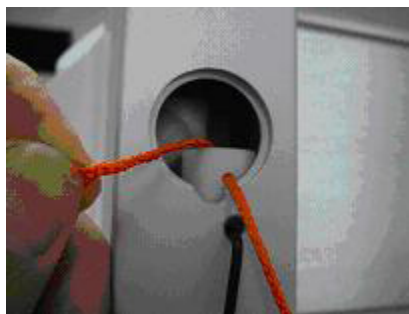

Figure 5-45 Securing String to the Spring Tube

10. Remove the wrench from the cross hole in the spring tube and lower the tube to the bottom of travel with the string.
11. Remove the lower M5 nut from the spring tube assembly at the bottom of the rail.



Figure 5-46 Removal of the Lower M5 Nut

12. Lift the rod out of the bracket.
13. Lower the spring tube assembly out of the rail assembly.
14. Remove the string from the old spring tube assembly and secure it to the new spring tube assembly.
15. Thread the new spring tube assembly into the rail assembly by raising it with the string.
16. Insert and secure the rod in the bracket. Position the opposing M5 nuts so that the bracket is approximately halfway up the threaded section of the rod. (Refer to "Figure 5-44 Heater Door Cable Adjustment".)
17. Using the string, pull the spring tube up until a 2mm hex wrench can be inserted through the inner rail and spring tube, temporarily securing the spring tube. Check that hex wrench is fully inserted in the hole in the opposite side of the inner rail.
18. Remove the string.
19. Re-secure the heater door cable end cap by screwing in the setscrew with a 2 mm wrench. Moderate tightening is correct.
20. Verify that the door cable is securely held in the spring tube by pulling on the cable.
21. Remove the hex wrench that was temporarily securing the spring tube to the inner rail. Allow the spring tube to hang on the cable.
22. Check that the dog point of the set screw, opposite the hex wrench, is protruding slightly from the spring tube.

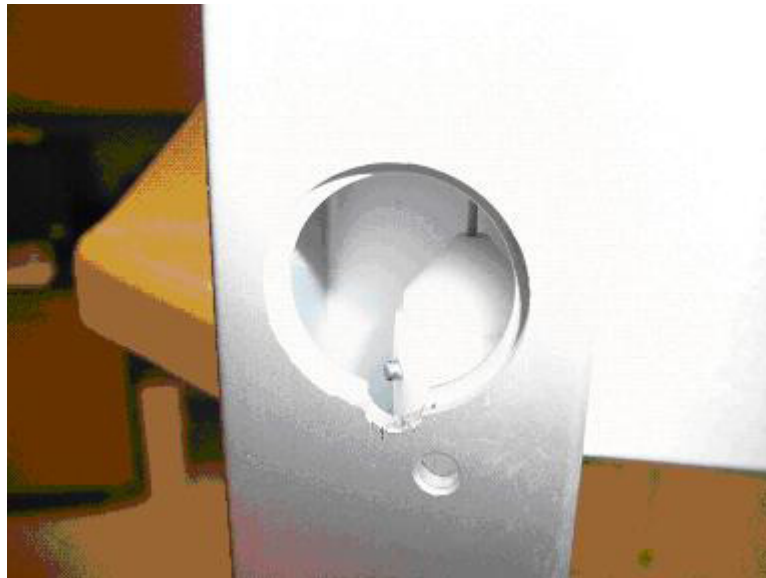

Figure 5-47 Dog Point of the Set Screw

If it is not, re-insert the securing wrench and retighten the set screw.

23. Re-install the hole plug.
24. Ensure that the opposing M5 nuts on the rod are tightened to the bracket. (Refer to “Figure 5-46 Removal of the Lower M5 Nut”.)
25. Plug the unit in and turn it on.
26. Raise the canopy to the upper position. Ensure that the heater doors open and the “IN TRANSITION” message is not shown. (Refer to section 5.6.4.)
 - If the heater doors do not open all the way so the “IN TRANSITION” message still shows, loosen, adjust the rod down relative to the bracket and re-tighten.
 - If the heater doors are all the way open against their mechanical stop and the “IN TRANSITION” message still shows, loosen and adjust the rod up relative to the bracket.

The least amount of tension that fully opens the doors is preferred.

27. Lower the canopy. Ensure that the canopy closes completely.
28. Reinstall the lower end cap. Reposition the appearance strip to cover the end cap screw.
29. Cycle the canopy up and down several times to verify operation.
30. Perform the complete pre-use checkout before returning the unit to service. For instructions, refer to Chapter 2.

5.7 Compartment Air Probe Repairs

Refer to "Figure 5-48 Compartment Air Probe Disassembly".

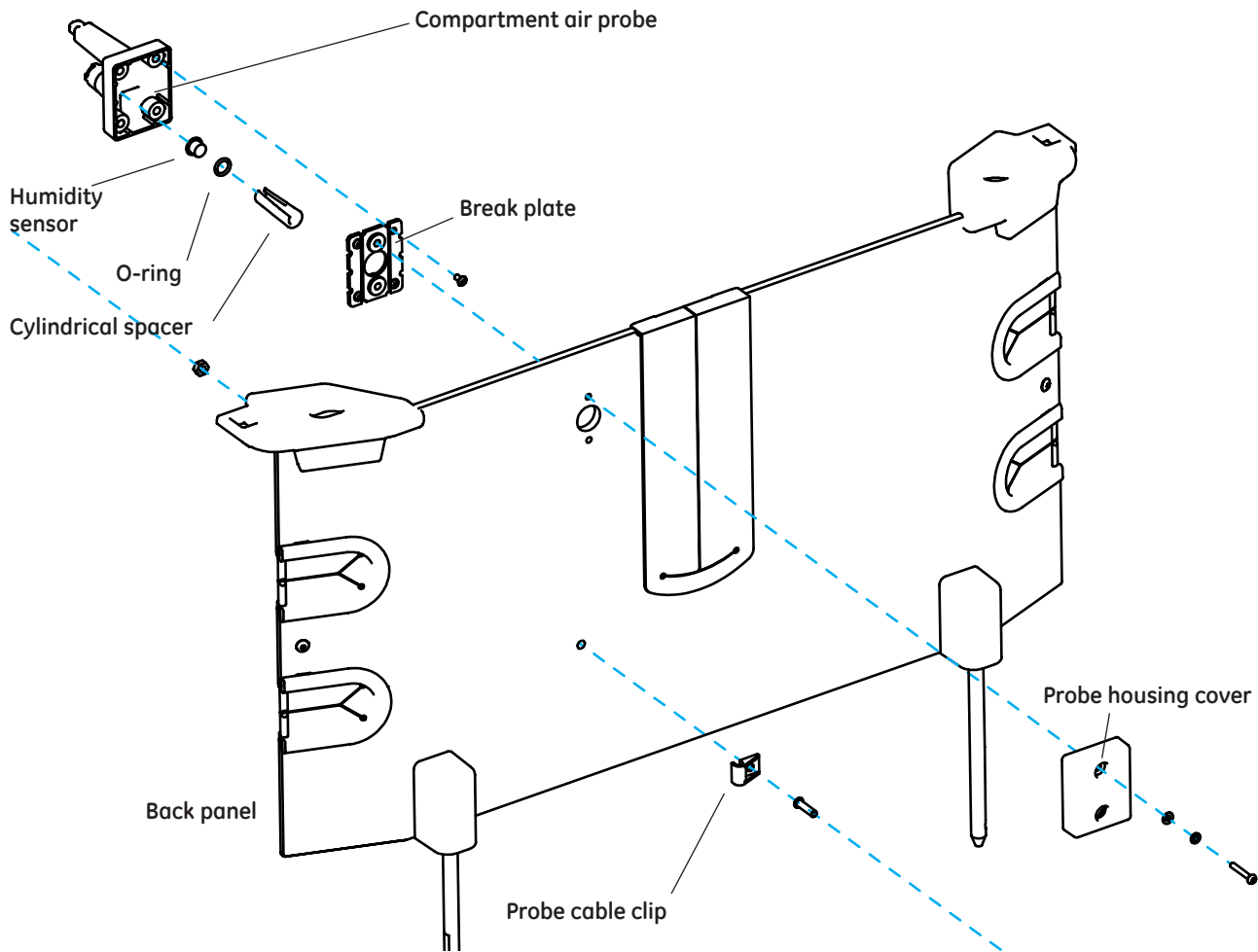

Figure 5-48 Compartment Air Probe Disassembly

1. Using a 2.5 mm hex key, remove the screw that secures the probe cable clip to the back wall.
2. Remove the 2 screws (2mm hex key) that secure the probe housing cover and remove it.
3. Disconnect the connectors for the temperature and humidity sensor (if installed) wires and remove the compartment air probe.

NOTE: Some early units have compartment air probes with jack connectors at the probe panel and should be disconnected there. For these units you must order kit number 6600-0241-850 to replace the probe and wire harness.

4. Feed the probe cable through the hole in the back wall and remove the front of the probe housing.
5. Remove the 4 screws in the break plate and remove the plate.

6. To replace humidity sensor, pull it back out of the probe housing. Slide the wires out of the cylindrical spacer. Place the O-ring over the tip of the new sensor, and gently push it back into the housing using the cylindrical spacer until the O-ring seats. The sensor tip should be visible, but not up against its guard. Check to ensure that the O-ring did not roll over the sensor flange during insertion.

NOTE: Perform the Humidity Calibration after replacing the humidity sensor.

7. To replace the temperature sensor, you must replace the entire probe housing.
8. When reassembling the probe housing make sure the groove in the break plate faces the probe housing cover. Also check that the temperature sensor is oriented so that it is on top.

5.8 Removing the Upper End Cap Spring

Refer to "Figure 5-49 Top Rail End Cap".

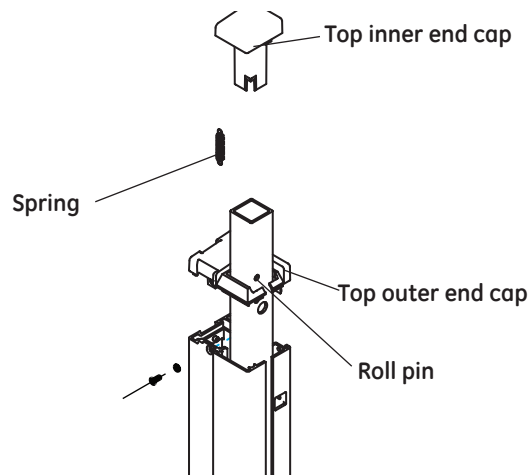

Figure 5-49 Top Rail End Cap

1. To replace the retaining spring, use a punch to push the roll pin in the top of the lift rail out about $\frac{1}{4}$ inch and remove the old spring.
2. Remove the old spring from the end cap.
3. Use a needle nose pliers to hook one end of the new spring onto the roll pin.
4. Push the roll pin back into the rail with the new spring attached.
5. Hook the other end of the new spring with a 1.5 or 2 mm "long" hex key and stretch it up into the shaft of the end cap. Hook it on the roll pin inside the end cap shaft.

5.9 Lower Unit Repairs

5.9.1 Removing the Chassis Cover with the Storage Drawer in Place

Refer to "Figure 5-54 Chassis Bottom Cover".

NOTE: It is not necessary to remove the storage drawer before removing the chassis cover, but you may wish to remove it to provide easier access to the chassis cover.

1. Remove the humidifier reservoir.
2. Slide the drawer all the way over in one direction, and use a 2.5 mm hex key to remove the 3 chassis cover screws on one side.
3. Slide the drawer to the other side and remove the 3 remaining screws from the cover.
4. Remove the bottom 2 screws (2mm hex key) that secure the right end of the humidifier wire raceway cover.
5. Flex the raceway cover and carefully slide the cover panel forward until it drops off the back drawer slide.
6. Rotate the cover slightly and push it out the right side of the unit.
7. Remove the ground wire.

5.9.2 Incubator Fan, Fan Motor, and Optical Fan Sensor

Refer to “Figure 5-50 Bed Disassembly”, “Figure 5-51 Heat Sink and Fan”, and “Figure 5-52 Fan Motor”.

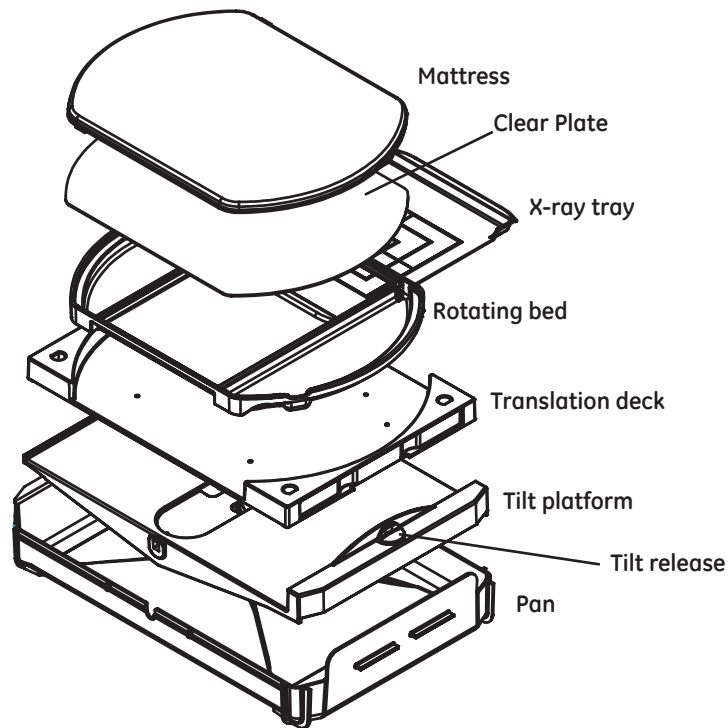

Figure 5-50 Bed Disassembly

1. Remove the rotating bed, translation deck, tilt platform, and pan.
2. Remove the fan, fan hub, and fan seal from the top of the fan motor shaft.
3. Remove the chassis cover. (Refer to section 5.9.1)
4. Disconnect the motor leads.
5. Remove the 4 screws in the motor bracket and remove the fan motor assembly.
6. The motor isolators pop out of the holes in the bracket.
7. To replace the optical sensor, disconnect its connector, remove the screw from the boss in the chassis that holds it in place, and remove the assembly.

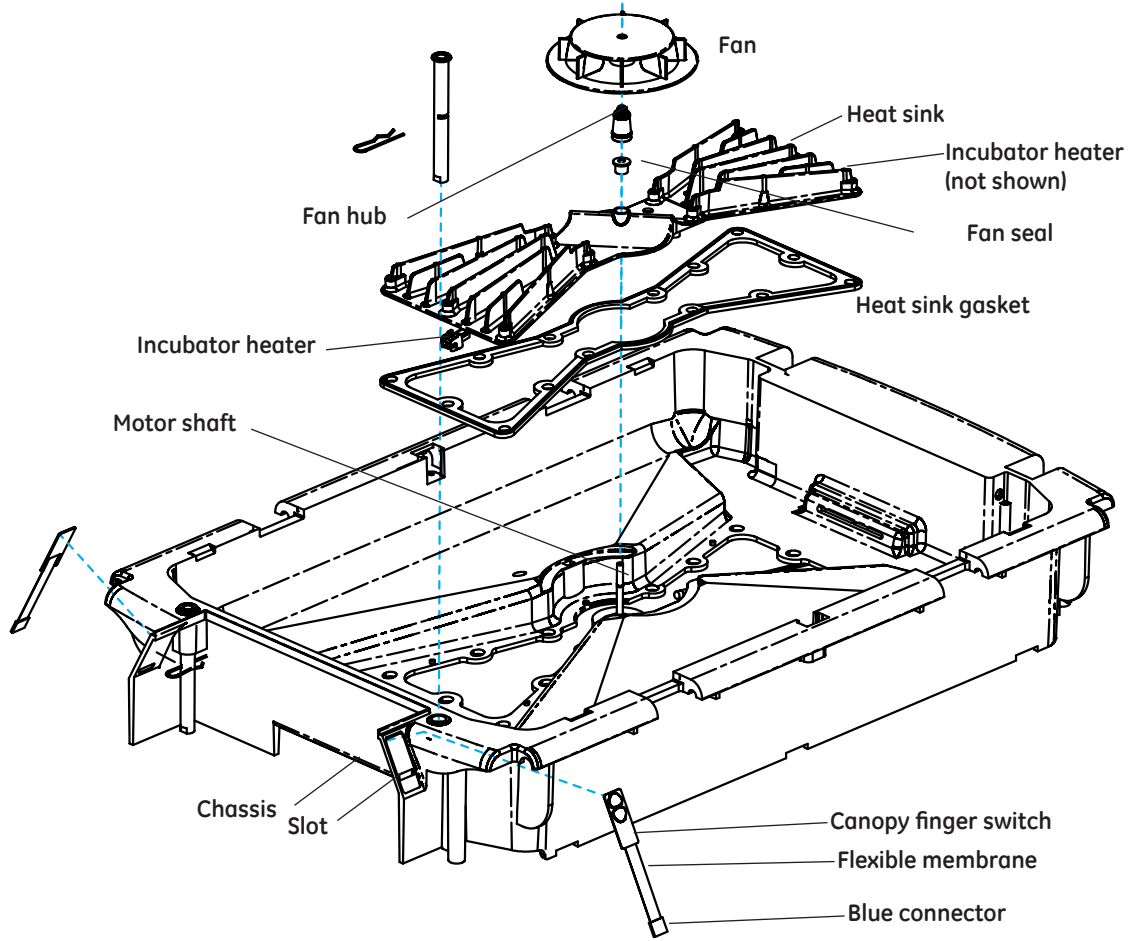

Figure 5-51 Heat Sink and Fan

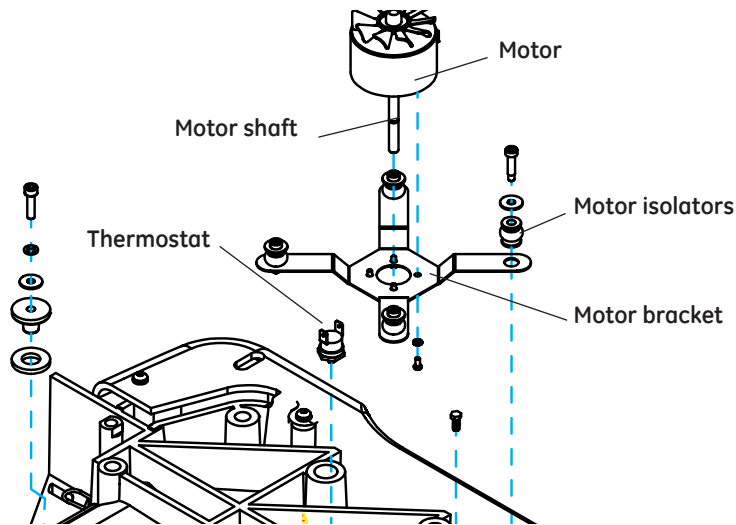

Figure 5-52 Fan Motor

5.9.3 Incubator Heater Replacement

Refer to "Figure 5-51 Heat Sink and Fan", "Figure 5-53 Elevating Base", and "Figure 6-13 Upper Chassis".

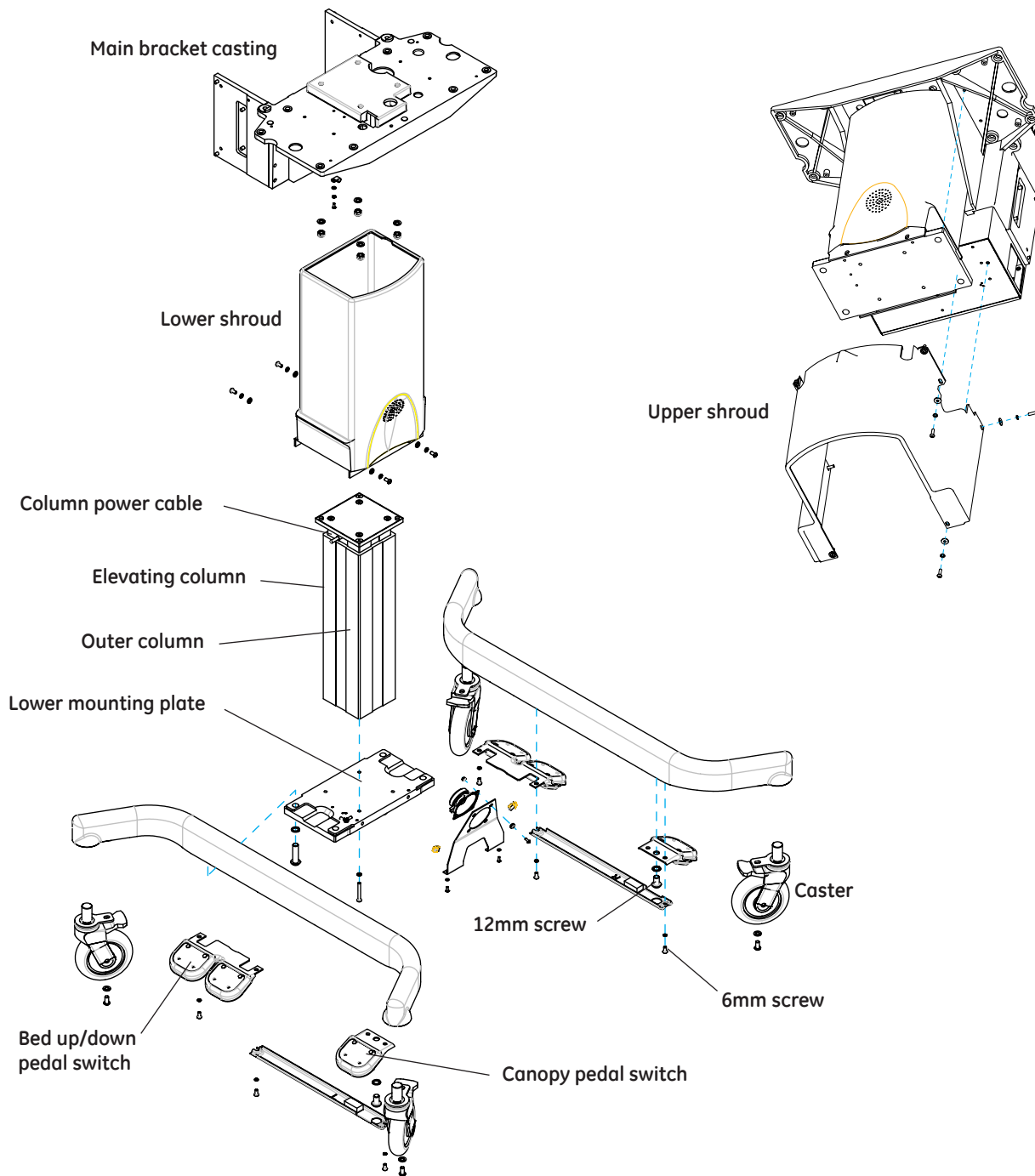

Figure 5-53 Elevating Base

Before disconnecting the power, raise the bed to a comfortable working height.

5.9.3.1 To Remove the Incubator Heater Closest to the Foot of the Bed

1. Remove the chassis cover. (Refer to section 5.9.1.)
2. Remove the screw (4mm hex key) in the heatsink directly in front of the heater cartridge.
3. Disconnect the heater's electrical connector.
4. Remove the retaining clip and slide the heater out of the heat sink.

NOTE: On early units, the incubator heater screwed into a threaded hole in the heat sink. For these units you must order kit 6600-0228-850 to replace both the heaters and heatsink.

5.9.3.2 To Remove the Incubator Heater Closest to the Head of the Bed

1. Remove the rotating bed, translation deck, tilt platform, and pan.
2. Remove the fan, fan hub, and fan seal from the top of the fan motor shaft.
3. Remove the chassis cover. (Refer to section 5.9.1.)
4. Disconnect the heater's electrical connector, the thermostat connections and the heat sink sensor connector.
5. Remove the upper shroud.
6. Remove the 14 mounting screws that secure the heat sink. Remove the heatsink.
7. Remove the retaining clip and slide the cartridge out of the heat sink.

NOTE: On early units, the cartridge screwed into a threaded hole in the heat sink. For these units you must order kit 6600-0228-850 to replace both the heater cartridges and heatsink.

8. To reassemble, seat the fan seal in the center bore of the heatsink and use it to align the fan shaft before fully securing the heat sink with its mounting screws. It may be necessary to wet the fan hub to allow it to slide all the way onto the fan shaft and seat properly.

5.9.4 Elevating Base

Refer to “Figure 5-50 Bed Disassembly” and “Figure 5-53 Elevating Base”.

1. Run the elevating base to its top travel limit.
2. Remove the mattress, bed, translation deck, tilt platform, and pan.
3. Run the canopy to its lowest position (closed). Use the shipping locks (Figure 5-14) to lock the canopy in the down position. Switch off and unplug the unit.
4. Remove the chassis cover. (Refer to section 5.9.1.)
5. Disconnect the elevating base electrical connector at J-45 on the relay board, and tie a wire to it so you can fish it back through during reassembly.
6. Connect the replacement elevating base to the relay board, switch the unit back on and using the foot pedals fully extend the new base. Switch off and unplug the unit.
7. Using a 4mm hex key remove the 4 screws (at the bottom of the base- 2 in back and 2 in front) that secure the lower shroud and slide it up past the speaker.
8. Using 3mm hex key remove the 8 screws that secure the upper shroud and remove it.
9. Pull the base wire harness out from the bracket casting.
10. Lock the back casters and lay the unit down on its back (controller on the floor). Place blocks under the uprights so the back casters are off the floor.
11. Using a 4mm hex key, remove the four socket head screws in the bottom of the elevating base that secure the lower mounting plate to the base, and remove the mounting plate/leg assembly.
12. Using a 13mm socket, remove the 4 nuts that secure the elevating base to the casting and remove the base.

NOTE: Should the elevating base fail in the completely retracted position, the outer column will prevent access to the 4 base mounting nuts. To remove the outer base, you must first remove the lower mounting plate and slide the outer column out. This requires a T-30 Torx key (service tool number 6600-1204-400)

13. To replace the elevating base, reverse the assembly steps above. Check that the casters are still locked before lifting the unit back into its upright position. If you are returning the old elevating base in its original packaging, attach it to the relay board and run it down to its fully retracted position. Release the shipping locks.

NOTE: With the unit on its back, be sure the base power cable is pointing up before you attach the base.

5.9.5 Chassis Replacement

Refer to “Figure 5-50 Bed Disassembly”, “Figure 5-51 Heat Sink and Fan”, “Figure 5-52 Fan Motor”, “Figure 5-54 Chassis Bottom Cover”, and “Figure 6-13 Upper Chassis”.

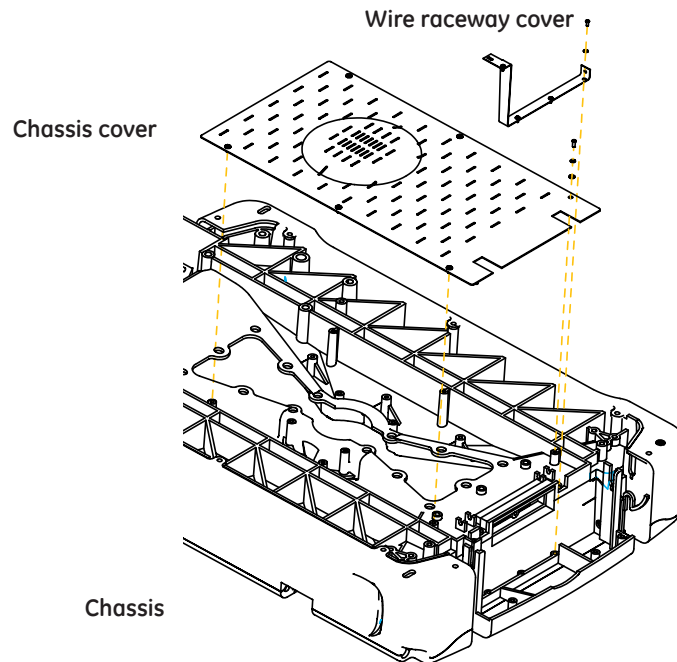

Figure 5-54 Chassis Bottom Cover

1. Remove the bedsides, rotating bed, translation deck, tilt platform and pan.
2. Disconnect the compartment probe jack from the probe panel.
3. Remove the bottom chassis cover. (Refer to section 5.9.1.) Remove the two side chassis covers (3 mm hex key).
4. Remove the front wall.
5. Disconnect the wiring harnesses.
6. Remove the two screws at the bottom corners that secure the probe panel to the enclosure. (Refer to section 5.13.2.)



WARNING:

Be sure the front of the chassis is supported before removing the screws from the bracket to prevent the chassis from falling.

7. While supporting the chassis, remove the 5 bolts on either side of the bracket casting that secure the chassis to the bracket and remove the chassis.

8. Remove all the components from the old chassis (bed tilt; fan and motor; heatsink; humidifier; etc.) and install them on the new chassis.

5.9.6 Bed Up/Down Pedal Switch

Refer to "Figure 5-53 Elevating Base".

1. Run the bed up to the elevating base's top travel limit. Power down the unit and unplug it.
2. Using a 4 mm hex key remove the 4 screws (at the bottom of the base- 2 in back and 2 in front) that secure the lower shroud and slide it up past the speaker.
3. Make note of the switches' electrical wire routing; the cable from the replacement switch must feed up through the same slot.
4. Using a 4 mm hex key, remove the button head socket screws on either side of the pedal switch, located between the elevating base plate and the leg wire cover.
5. Disconnect the switch electrical connector and pull the switch out. Discard old bed up/down pedal switch.
6. Install new bed up/down pedal switch. Make sure that you do not pinch the electrical wires.

5.9.7 Canopy Pedal Switch

Refer to "Figure 5-53 Elevating Base".

1. Using a 4 mm hex key and a 8mm hex key, remove the screws that secures the pedal.
2. Disconnect the switch electrical connector and pull the pedal out . Discard old canopy pedal switch.
3. Install new canopy pedal switch. Replace the 12mm screw first, then the 6mm screw. Make sure that you do not pinch the electrical wires.

5.9.8 Canopy Membrane Switch Replacement

Refer to "Figure 5-51 Heat Sink and Fan".

1. Adjust the elevating base to comfortable working height.
2. Remove the electronics enclosure cover.
3. Remove the two screws holding the probe panel housing to the electronics enclosure.
4. Rock the probe panel housing forward and up, allowing access to the gray membrane switch wiring harness.
5. Gently pull the gray wire harness up, this will pull up the membrane switch/harness connection, allowing you access to the connector.

6. Disconnect the membrane switch. If you intend to replace the plastic adhesive connector locking pieces, you can discard the old ones. Otherwise, save the plastic adhesive connector locking pieces to reinstall with the new membrane switch.
7. Remove the old membrane switch, pulling the connector through the slot in the chassis. (The blue connector may pull off the old/damaged membrane switch, but it will drop through to the floor.)
8. Clean the old switch adhesive from the chassis.
9. Feed the new membrane switch connector through the slot. Do not attach/stick the new membrane switch to the chassis yet.
10. Use a piece of heavy wire to fish the blue connector of the new membrane switch up from behind the switch panel so that you can connect it to the black connector of the gray membrane switch wiring harness.
11. Connect the blue and black connectors. Secure the connection using the plastic adhesive connector locking pieces that you saved in step 6 or a new one (part number 6600-0572-600).
12. Tuck the connector assembly down between the chassis and the electronics enclosure.
13. Remove the adhesive backing on the new membrane switch and attach it to the chassis.
14. Replace the probe panel housing in its correct position.
15. Replace the two screws holding the probe panel housing to the electronics enclosure.
16. Replace the electronics enclosure cover.
17. Perform the post-service checkout including electrical safety.

5.10 Bed Tilt Brake Pad Replacement

Refer to “Figure 5-50 Bed Disassembly” and “Figure 5-55 Replacing the Tilt Brake Pad”.

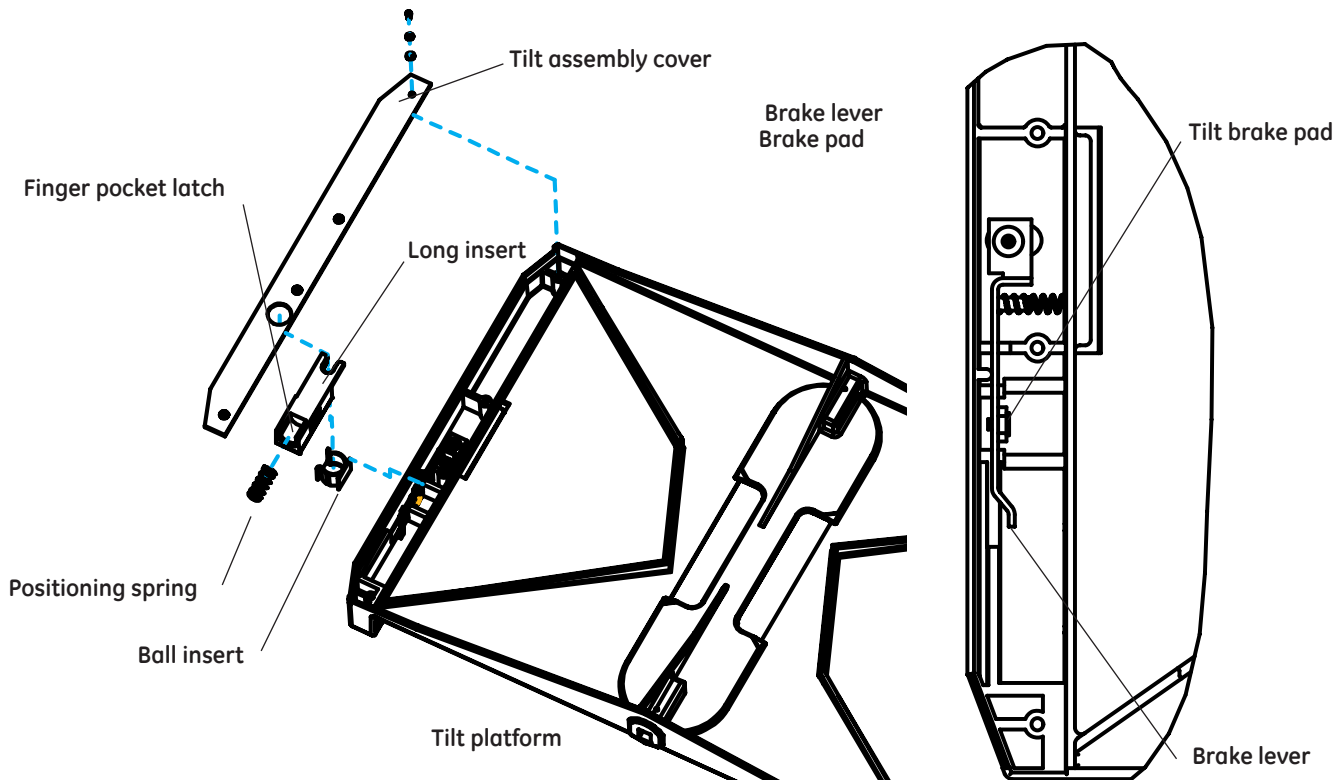

Figure 5-55 Replacing the Tilt Brake Pad

1. Remove the mattress, clear plate, rotating bed and translation deck.
2. To release the tilt screw ball, squeeze the tilt release and slide open the finger pocket latch until you hear the ball drop.
3. Release the tilt platform from the chassis by pushing the pivot pin tabs in on both sides, then lifting the tilt platform out of the chassis.
4. Turn the tilt platform over and remove the 4 screws (2.5 mm hex key) that secure the tilt assembly cover.
5. Remove the two plastic inserts. The long insert holds a positioning spring and the smaller ball insert holds the screw ball in position.
6. Press back the brake lever to provide access to the tilt brake pad, then use pliers or a thin 14mm open end wrench to remove the nut to which the brake pad is fastened. Replace the tilt brake pad assembly and reassemble.

5.11 Caster Replacement

Refer to "Figure 5-53 Elevating Base".

The casters may be replaced with the unit upright or carefully placed on its back. You may wish to lock the canopy in its shipping position.

1. Lock all the other casters.
2. Lift the caster off the floor and use blocks to support the leg near the caster you are replacing.
3. On newer casters with mounting plates, remove screw from boss underneath the leg casting.

On older casters with a set screw on the side of the leg casting, remove the screw on the side of the leg that holds the caster in its mounting hole. Remove the caster.

NOTE: The new style caster with a mounting plate has a different shaft diameter than the older caster and will not fit on the older set screw style leg casting.

4. On newer casters, secure the caster to the leg by tightening the screw through the caster plate into the boss in the bottom of the leg.
5. On older casters, line up the hole in the caster stem with the set screw hole in the leg and insert the caster. Apply Loctite #242 to the screw. As you tighten the screw the caster should be drawn into the leg.

NOTE: If you are replacing a caster hub cover, you must use an 1/8" drill to remove the old cover stem before snapping the new hub cover in place.

5.12 Humidifier Assembly Repairs

Refer to "Figure 5-54 Chassis Bottom Cover" and "Figure 5-56 Humidifier Parts".

A design change was made to the humidifier assembly to make it easier to remove the screws during disassembly. Units shipped since about March 2002 have this revised design. The earlier design can be identified by the button head cap screws used in the assembly. The later design uses Phillips head screws to make disassembly easier.

When working on the earlier design if you have difficulty with disassembly you may wish to replace the entire humidifier assembly with the later design 6600-0245-850 . When disassembling the older design, we recommend that you replace the old screws with the new screws listed below. You may also require the other parts listed below if they are damaged during disassembly. (Refer to section 5.12.1.)

The reservoir switch button was also redesigned to prevent it jamming in the closed position. You should also replace this button when working on an old style humidifier.

Qty. per assy.	Description	Part Number
3	Screw, M3 X 8, Phillips head, Teflon coated	6600-1255-401
4	Screw, M3 X 10, Phillips head, Teflon coated	6600-1255-402
4	Screw, M3 X 12, Phillips head	6600-1255-403
2	Screw, M3 X 16, Phillips head	6600-1255-404
4	Spacer, .125 ID	6600-1779-500
1	Ramp block	6600-1777-500
1	Heater mount	6600-1291-500
1	Button, reservoir switch	6600-1298-500

5.12.1 Tips for Repairing an Old Style Unit

Some of the hex head screws may be difficult to remove. To minimize the chances of stripping the heads, be sure that the 1.5 mm Allen key you are using is not worn, and is not a ball head style. If you strip the heads, you may need to drill them out. If you drill out the heads, you may need to replace the ramp block and/or the heater mount if you have difficulty in removing the body of the screw.

5.12.2 Disassembly

1. Remove the humidifier reservoir.
2. Remove the 6 screws that secure the wire raceway cover and remove the cover.
3. Remove the chassis cover. (Refer to section 5.9.1.)
4. Disconnect the 3 electrical connectors.
5. Remove the 2 screws on either side of the heater assembly.
6. Remove the heater assembly.
7. Use a 2mm hex key to remove the 2 screws from the reservoir switch and remove the switch.
8. Remove the 4 screws that secure the top bracket. Back the bracket off feeding the wire harnesses through as you remove it.
9. Remove the top gasket, feeding the wire harnesses through as you remove it. The thermostat wire harness can slide through the slots in the gasket.
10. Remove the 4 screws in the heater mount and remove the bottom bracket.
11. Remove the socket head cap screw next to the add water thermostat, then remove the bottom gasket, insulating cylinder, and protective insert.

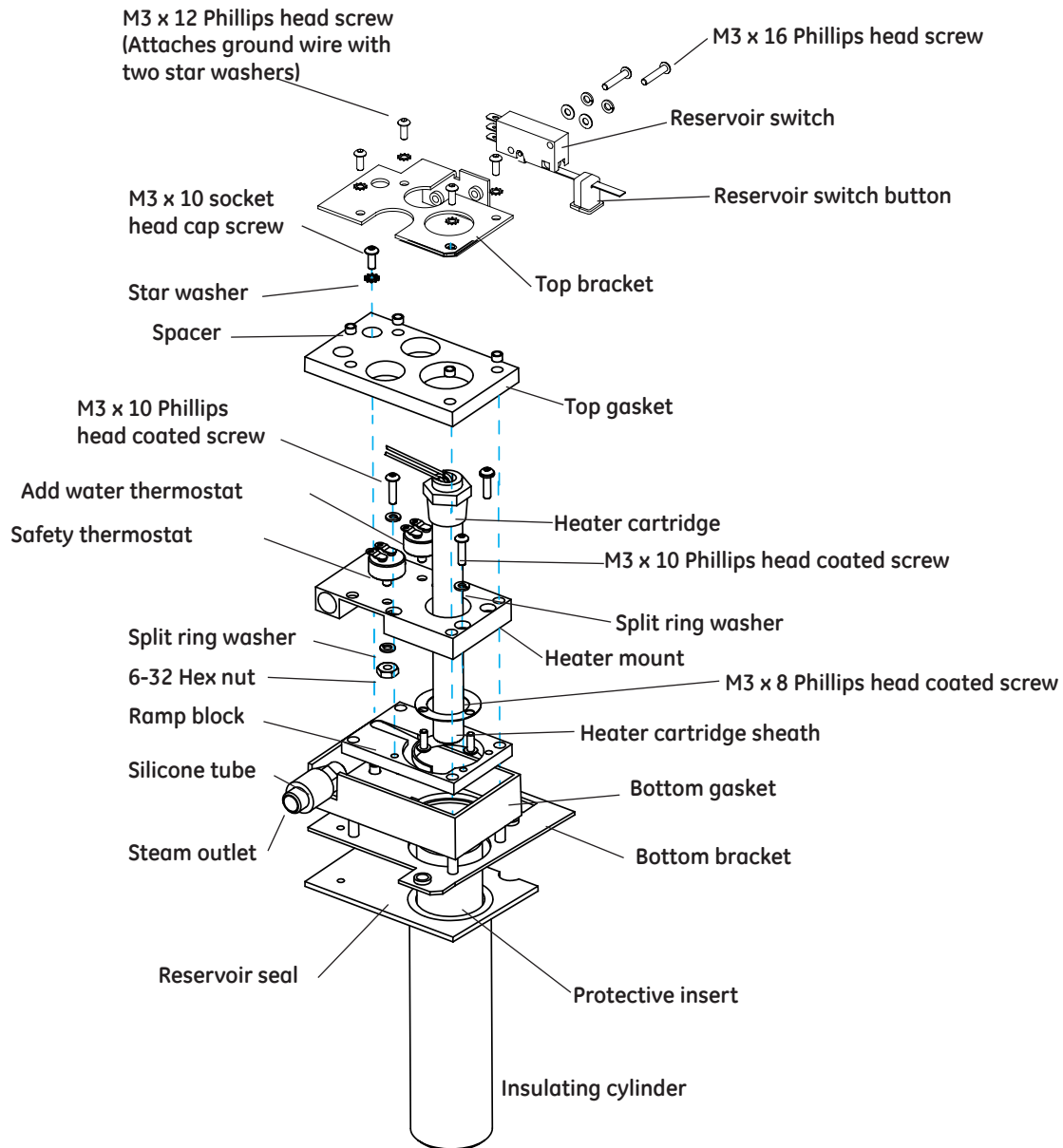

Figure 5-56 Humidifier Parts

12. Remove the 3 screws in the heater cartridge sheath.
13. To remove the heater cartridge, unscrew it from its threaded hole.
14. The thermostats can be replaced by removing the nuts securing them to the ramp block.

If either thermostat or the heater cartridge is being replaced, check all components (especially the plastic ones) for signs of heat damage or corrosion. We recommend replacing the sheath when replacing the heater cartridge.

5.12.3 Reassembly

1. Screw the steam outlet in the threaded hole on the heater mount.
2. Slide the silicone tube on the steam outlet flush to the hex.
3. Screw the heater cartridge assembly into the heater mount, then back it off so the harness exits between the two thermostat mounting holes.
4. Attach the heater sheath with the three M3 x 8 Phillips Teflon coated screws and split ring lock washers to the bottom of the heater mount.
5. Place two M3 x 10 Phillips Teflon coated screws and split ring lock washers into the heater mount counter bore holes next to the thermostat mounting holes.
6. Attach the two thermostats to the mounting block with the 6-32 hex nuts and split ring lock washers, being careful not to position the thermostat wires over the mounting holes in the heater mount. The add water thermostat has the micro-switch attached to the harness.
7. Attach the ramp block to the heater mount with the two screws placed in the counter bore holes above, and with two additional M3 x 10 Phillips Teflon coated screws and split ring lock washers.
8. Place the protective insert inside the insulating cylinder. Slide the bottom gasket over the insulating cylinder then over the ramp block.
9. Align and slide the posts of the bottom bracket through the bottom gasket, then through the ramp block.
10. Install an M3 x 10 socket head cap screw and star washer through the hole in the heater mount next to the add water thermostat. This screw grounds the bottom bracket so do not use a Teflon coated screw.
11. Route the heater and thermostat wire harnesses through the top gasket.
12. Install the top gasket and place the 4 0.125ID x 0.107L spacers into the gasket holes.
13. Route the heater and thermostat wire harnesses through the holes in the top bracket.
14. Install the reservoir switch button up through the bottom bracket and slide the switch actuator lever through the button slot.

NOTE: Old style button installs down through the bracket.
15. Attach the reservoir switch to the top bracket using the two M3 x 16 Phillips screws, flat washers, and split ring lock washers.
16. Align the top bracket with the mounting holes and install the four M3 x 12 Phillips screws and star washers through the 4 holes in the top bracket. Attach the ground wire to the screw closest to the switch, using two star washers.

17. Dress the wire harnesses and install a cable tie.
18. Slide the reservoir seal into place.
19. When installing the humidifier assembly, rotate the cylinder so the max line is visible.

5.13 Controller and Display Module Procedures

5.13.1 Display Module

Refer to "Figure 5-57 Display Module".

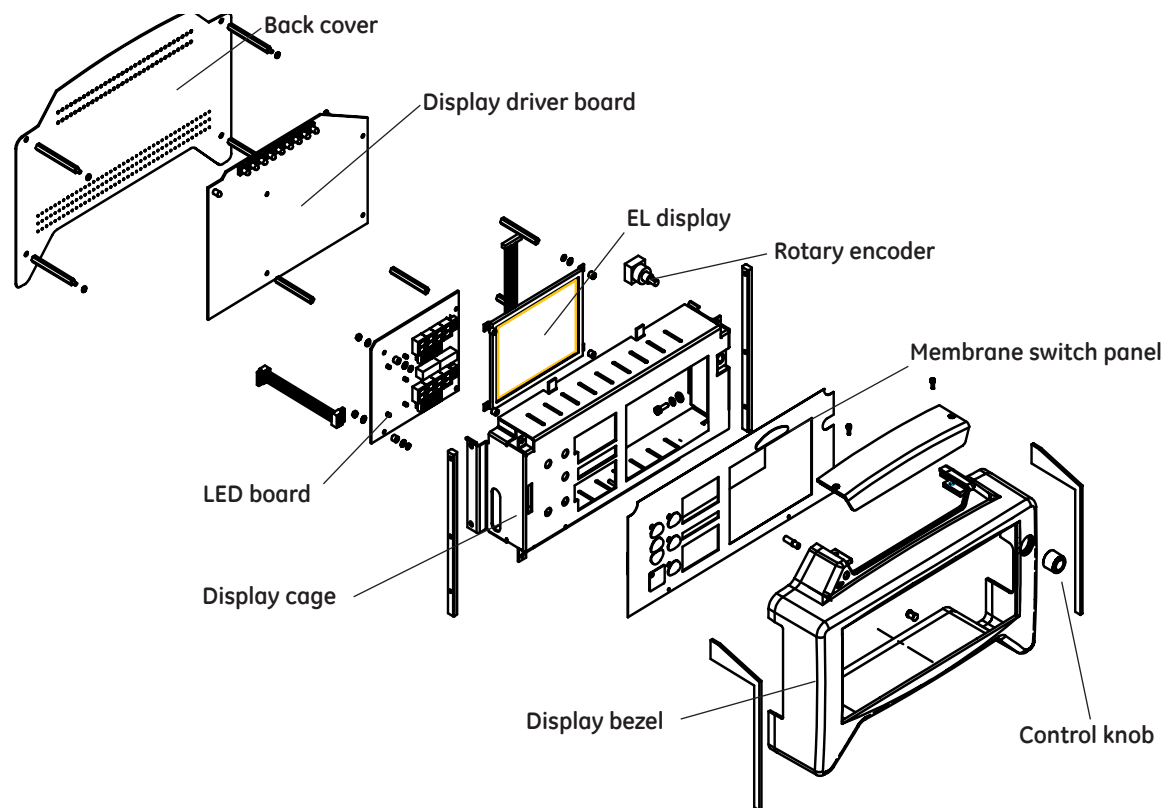

Figure 5-57 Display Module



1. Remove the 4 screws that hold the back cover on the display module and remove the cover.
2. To remove the display driver board, first remove the 4 screws that hold the board to the standoffs, then disconnect the electrical connectors.
3. To replace the rotary encoder for the EL display, pull the control knob off the shaft, disconnect the electrical connector, remove the nut that secures the encoder, and remove the encoder.

4. To remove the LED board, disconnect the electrical connectors, then remove the 2 standoffs (6mm wrench) that hold the board in place, and then the 2 nuts with hardware.
5. To remove the EL display, disconnect the electrical connectors, then remove the 2 nuts that hold the display in place. Be careful not to get finger prints on the display and be sure it is clean before replacing it.
6. The standoffs that hold the back cover also secure the bezel to the front of the display cage. Remove the standoffs (6mm wrench) and remove the bezel. To replace the membrane switch panel, first disconnect its electrical connector and then peel it off the display cage. Be careful to remove all residue adhesive from the module before installing a new membrane panel. The membrane panel can not be repositioned once it has been applied without damaging it.

5.13.2 Probe Panel

Refer to "Figure 5-58 Probe Panel" and "Figure 6-1 Probe Panel Assembly".

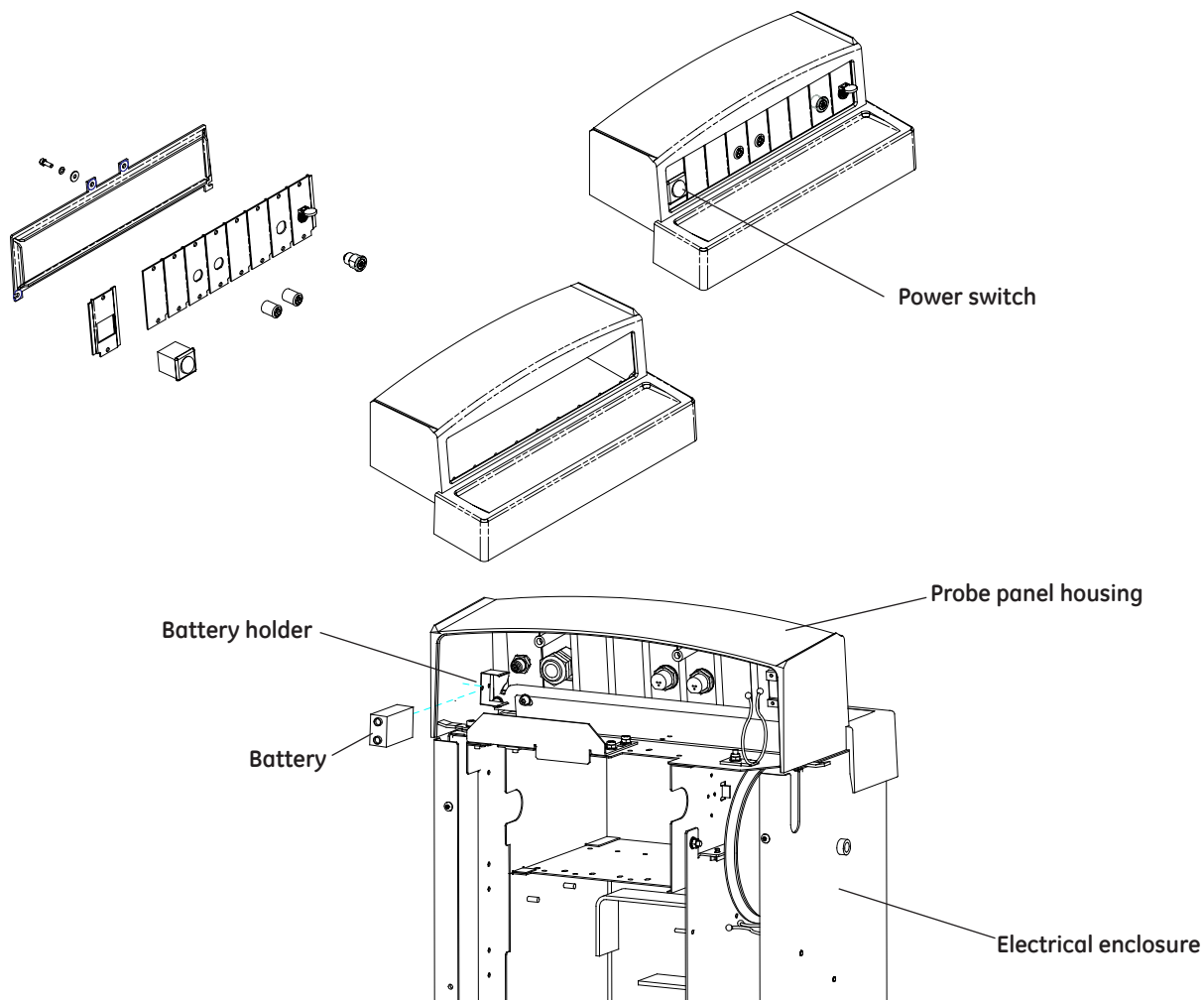

Figure 5-58 Probe Panel



1. Using a 2.5 mm hex key, loosen the 2 screws in the keyhole slots and remove the 6 remaining screws that secure the controller cover, then remove the cover. Disconnect the wire harnesses coming from the probe panel.
2. Remove the 2 screws at the bottom corners that hold the probe panel to the enclosure.
3. Remove the probe panel assembly.
4. While tilting the panel enclosure forward, use a 3mm hex key to remove the 4 screws that hold the panel frame in place. Add new jacks through the panel frame as appropriate.

NOTE: The power switch panel must be on the far left. The position of the remaining panels is not critical.

5.13.2.1 Battery

The battery snaps into a holder on the side of the probe panel housing. It has two snap connectors at its top. When replacing the battery, its easier to first connect the terminals then push the battery into its holder.

NOTE: Run the unit for at least two hours to charge the new battery before using the unit. The battery charges only when the unit is powered on.

NOTE: If your battery is in the electrical enclosure above the relay board, order relocation kit M1045981. This kit includes parts and instructions to relocate the battery to the probe panel to reduce battery ambient temperature and prolong battery life.

5.13.3 Controller Components

Refer to "Figure 5-59 Electronics Enclosure".

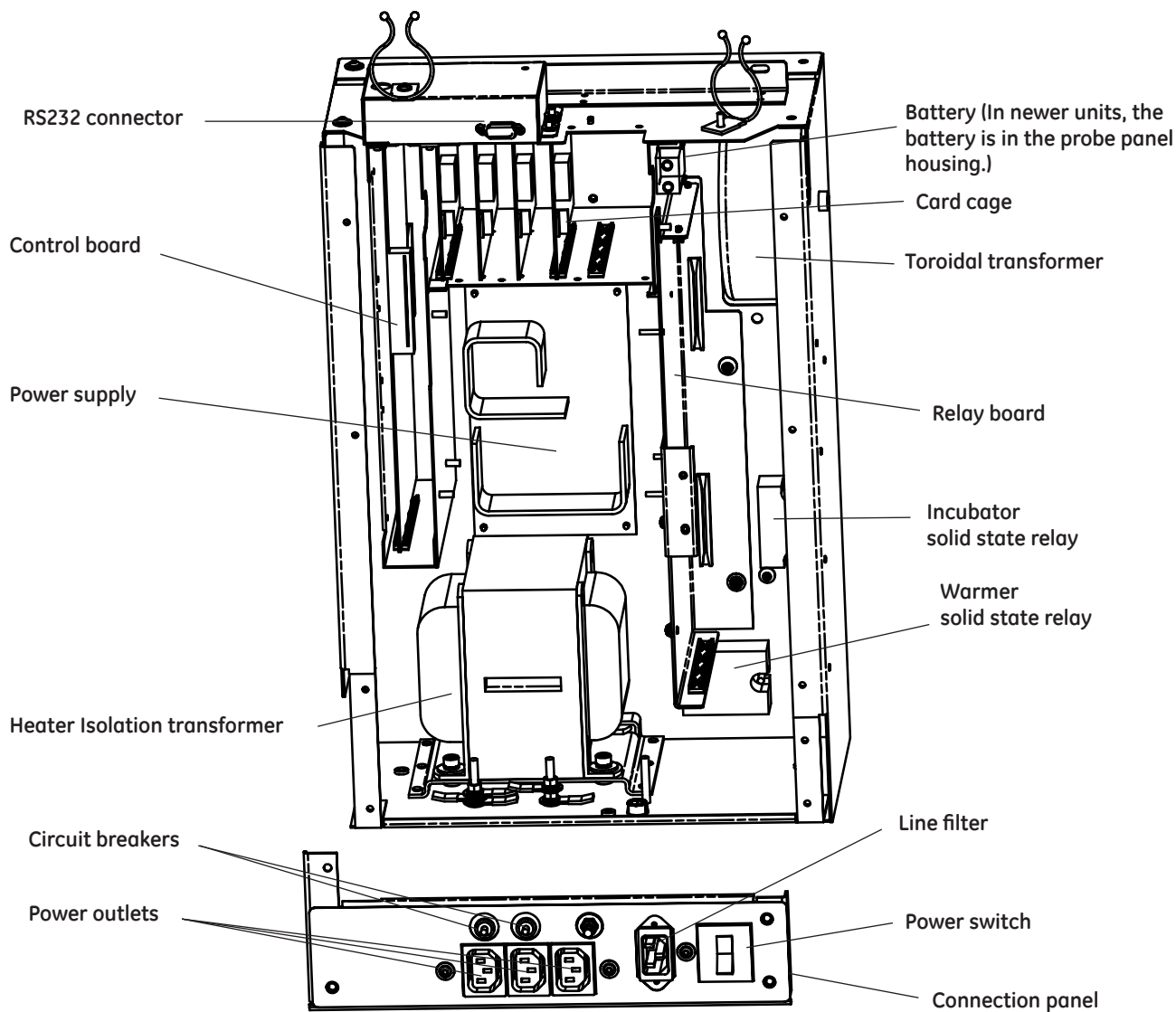

Figure 5-59 Electronics Enclosure



Using a 2.5 mm hex key, loosen the 2 screws in the keyhole slots and remove the 6 remaining screws that secure the controller cover, then remove the cover. Now you can access the electrical components listed below.

5.13.3.1 Control Board

Slide the control board out about an inch and disconnect all the electrical connectors along its outside edge, then remove the board.

Dipswitch configuration on replacement control boards. (Refer to Figure 6-39.)

- Switch 1 must be ON.
- Switch 2 must be ON (if board is used in an OmniBed).
- Switch 3 must be ON if servo humidifier is installed.
- Switches 4, 5, 6 and 7 are unused and should be OFF.
- Switch 8 must be OFF. (If switch 8 is on, unit will power up in service mode.)

NOTE: Always perform System Calibration and Humidifier calibration after replacing the control board.

5.13.3.2 Relay Board

Remove the two M3 hex nuts that secure the relay board retainer bracket with a 5.5 mm socket, then pull the board out a little and disconnect the electrical connectors on the outer edge. Then pull it out a little more and disconnect the connectors at the bottom end of the board. Now the board can be pulled out the rest of the way so the back connectors can be disconnected. You can now access the 2 fuses on the board.

NOTE: Always perform Line Voltage Calibration after replacing the relay board.

5.13.3.3 Solid State Relays

To replace either of the 2 solid state relays (the relays are identical and carry the same part number), disconnect their electrical connections, and using a 7mm wrench remove the 2 nuts that secure them to the enclosure.

5.13.3.4 Power Supply

To access the power supply, disconnect the 50 pin ribbon cable that crosses in front of it. To remove the power supply, use a 5.5 mm nut driver to remove the nuts that secure it.

After installing the replacement power supply perform the following tests:

To verify the power supply outputs are correct measure the following voltages on one of the unused connectors that feed power to the option boards. The voltages are not adjustable. If they are out of specification the power supply must be replaced.

Signal	Measure at	Acceptable Range
5 Volts	Pins 2 to 1	4.75 volts to 5.25 volts
12 volts	Pins 3 to 1	10.80 volts to 13.20 volt

5.13.3.5 Toroidal Transformer

To replace the elevating base toroidal transformer;

1. Disconnect the wire harnesses connected to the relay board and remove the board.
2. Using an 1/2" open end wrench loosen transformer retaining bolt.
3. Remove both the toroidal transformer and the retaining bolt. Save the bolt for installing the replacement transformer.
4. Disconnect the old transformer from its wire harness.
5. The replacement toroidal transformer comes with two 4" diameter rubber insulating washers that are installed on both sides of the transformer like a sandwich, and a 4" diameter metal mounting washer that is installed on the same side of the transformer as the head of the retaining bolt. To make aligning these parts easier during installation, you may wish to use electrical tape to attach the 3 large washers to the transformer.
6. Install the new transformer by passing the retaining bolt through the washers and transformer and into the threaded hole in the side of the electrical enclosure. Turn the transformer so you can see the label on the side transformer to orient the wire harness so it exits toward you, then finish tightening the retaining bolt.
7. Connect the transformer wire harness.
8. Reinstall the relay board and reconnect its wire harnesses

5.13.3.6 Canopy Lift Motor, ISO Transformer, Circuit Breakers, Power Switches, and Power Outlets

The canopy lift motor, ISO transformer, circuit breakers, power switches and power outlets can all be more easily accessed by removing the connection panel at the bottom of the enclosure by removing the 3 screws that secure it with a 2.5 mm hex key.

5.14 Servo Controlled Oxygen Service Procedures

5.14.1 Installing Oxygen Sensors

Refer to Figure 5-60.

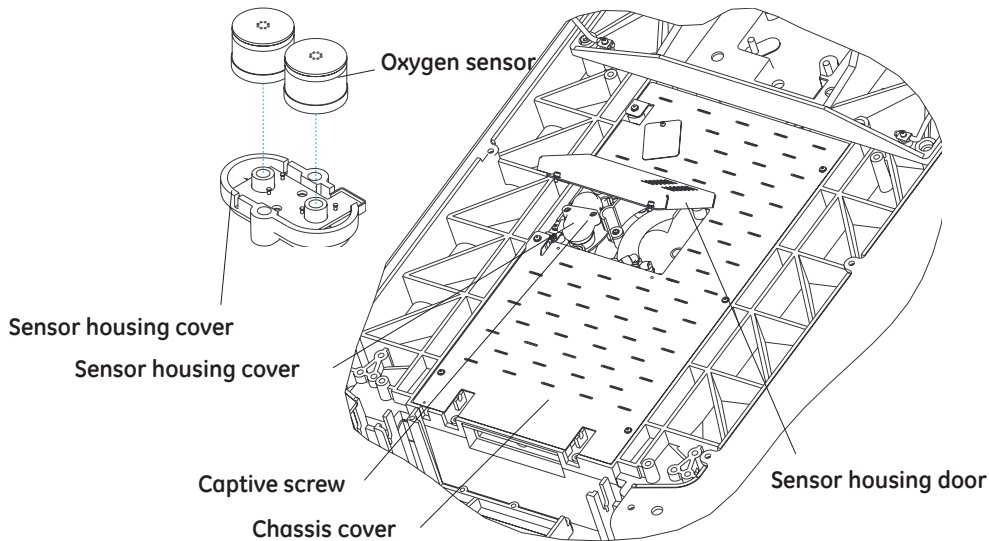

Figure 5-60 Installing Sensors

1. Slide the drawer to one side and using a 3mm hex key, loosen the captive screws in the chassis cover sensor housing door and swing the door down to access the sensor housing.
2. Using a 3mm hex key, loosen the two M4 socket head screws that secure the sensor housing cover, and remove the cover.
3. Remove the old oxygen sensors. Replace with two new sensors (6600-0120-850).

NOTE: The date on the sensor is a discard date; the sensor should be removed from service on this date. All sensors are shipped from Ohmeda at least 12 months prior to this date; sensors should be installed immediately to ensure maximum operating life.

4. Reinstall the sensor housing cover and close and secure the door in the chassis cover.
5. Perform the Pre-use Checkout.

5.14.2 Replacing the Vent Screen

1. Remove rotating mattress tray, tilt platform and upper pan.
2. Remove the vent cover by turning it counter clockwise.
3. Remove and discard the ring shaped vent filter screen from the chassis vent.

4. Install a new vent screen and reinstall the vent cover.
5. Perform the Pre-use Checkout.

5.14.3 Sensor Housing Repairs

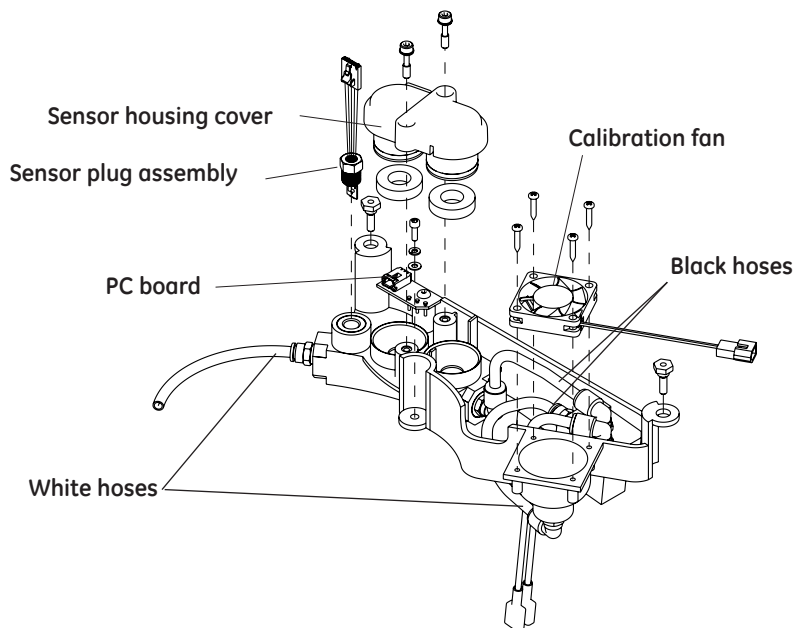

Figure 5-61 Sensor Housing

5.14.3.1 Sensor Housing Repairs: Boards, Calibration Fan Assembly, and Sensor Plug Assembly

1. Slide the drawer to one side and using a 3mm hex key, loosen the captive screws in the chassis cover sensor housing door and swing the door down to access the sensor housing.
2. Using a 3mm hex key, loosen the two M4 socket head screws that secure the sensor housing cover, and remove the cover.
3. To replace the half of the PC board inside the sensor housing cover, use 2.5 mm hex key to remove the 2 M4 button head screws that secure it to the cover.
4. To replace the half of the PC board inside the sensor housing, disconnect from the wire harness and remove the single M4 button head screw that holds it to the housing. Perform the Pre-use Checkout
5. To replace the calibration fan, disconnect its electrical connector and remove the 4 self tapping screws that secure it to the sensor housing. Install replacement fan so flow arrow on side points up into chassis. Perform the Pre-use Checkout



6. To replace sensor housing plug assembly, disconnect it from the sensor cable, and use a 7/16" open wrench to unscrew it from the housing, then disconnect its other electrical connector. In addition to taking static sensitive precautions, take care not to touch the sensor portion of the assembly with your fingers to avoid contaminating it. After you replace the plug assembly, perform the Pre-use Checkout.

5.14.3.2 Sensor Housing Repairs: Calibration Valve

1. Slide drawer to one side and remove three M4 screws that secure bottom cover to chassis.
2. Remove the humidifier reservoir by pulling forward from bottom. A sheet metal ground strap is located behind the reservoir. Remove the M3 screw that secures the strap to the bottom cover. Slide drawer to other side and remove remaining three M4 screws that secure bottom cover to chassis. Remove the cover by sliding out toward the right side of the unit.
3. Disconnect the ground cable from bottom cover. The ground cable is secured to a 4mm stud in the bottom cover with a nut and two internal tooth lock washers.
4. Disconnect the cooling fan cable.
5. Use a 2.5 mm hex key to remove the M3 screw that secures the center of the sensor housing to the chassis. Refer to "Figure 5-61 Sensor Housing".
6. Use a 10mm nut driver to remove the two stand-off fasteners that secure the sensor housing to the chassis.
7. Disconnect tubing from chassis and heat-sink vent fittings.
8. Disconnect all harnesses from sensor housing, and remove sensor housing from unit.
9. Remove the two M4 flat head screws that secure the calibration valve to the sensor housing, and remove calibration valve assembly.
10. Install new calibration valve assembly. Connect the black wire to the - terminal and the red to the + terminal.
11. Perform the Pre-use Checkout and Leak Check.

5.14.4 Valve Housing Repairs

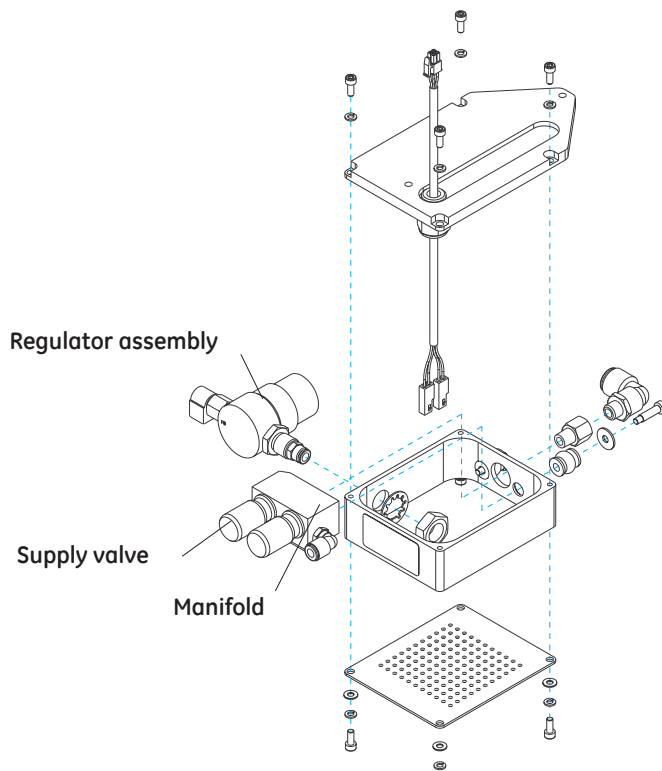

Figure 5-62 Valve Housing

5.14.4.1 Valve Housing Repairs: Regulator Assembly



1. Using a 3mm hex key, remove the 4 screws that secure the valve housing bottom cover and remove the cover.
2. Disconnect the tubing from the straight push-in fitting on the regulator assembly.
3. Using two adjustable wrenches, turn the 14mm hex nut on the inside of the housing while holding the hex on the regulator on the outside of the housing to loosen the assembly. Remove the regulator assembly.
4. To replace the regulator inlet filter, use a wrench to remove the elbow fitting, then turn the filter fitting off the regulator. Before installing a new filter, make sure all old PTFE tape remnants are removed and new tape is applied.
5. When installing the new regulator assembly, be sure to replace the M14 lock washer under the 14mm hex nut. Hold the regulator so that when it is installed the oxygen supply fitting points straight down at the floor. Perform the Pre-use Checkout.

5.14.4.2 Valve Housing Repairs: Supply Valves

1. Remove the regulator assembly as described in steps 1 through 3 above.
2. Disconnect the supply valves electrical connector.
3. Use a pair of pliers to turn the valve out of the manifold block.
4. When installing a new valve, finger tighten it into the manifold. Perform the Pre-use Checkout Supply Valve Leak Test.

5.14.5 Endcap Safety Valve

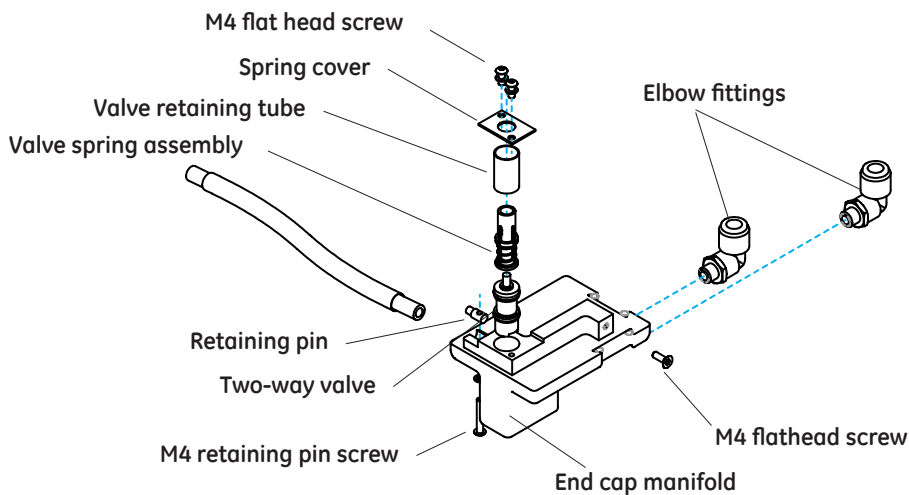

Figure 5-63 Endcap Safety Valve



1. To remove the endcap manifold, slide up the dovetail rail trim strip to access the M4 flathead screw (2.4 mm hex key) end cap screw, and remove the screw. Loosen the M4 retaining pin screw and tilt the manifold to disengage the retaining pin from the hole in the dovetail rail and remove the manifold.
2. To replace any of the valve's internal parts, remove the two M4 flat head screws.
3. Use a needle nose pliers to pull the two-way valve from the bore in the manifold. When replacing the valve make sure to lubricate its two O-rings with Vac Kote (6700-0092-200).
4. When reinstalling the manifold, tighten the M4 flathead screw first, then tighten M4 retaining pin screw. Perform the Supply Valve Leak Test and Pre-use Checkout.

5.14.6 Servo Oxygen Board Repairs

1. Use a 2.5 mm hex key to loosen the 2 screws in the keyhole slots and remove the 6 remaining screws that secure the electrical enclosure cover, then remove the cover.
2. The Servo O2 Board is located in the second slot of the option card cage. The 485 data cable, sensor housing cable, calibration cable and cooling fan cable are attached to it. The board can be slid part way out of its guide to access its connectors or to replace the U6 EPROM. Perform Pre-use Checkout.

Chapter 6: Illustrated Parts

This chapter provides illustrated parts of the Giraffe OmniBed.

For illustrated parts of the Giraffe Scale, refer to the Giraffe Scale Service Manual, which can be ordered as part of a Giraffe OmniBed service manual kit: (US) 6600-0834-801 or (INTL) 6600-0834-802.

6.1 Exploded Views

The exploded views begin on the next page.

6.1.1 Probe Housing, Display Module, and Electrical Enclosure

1. Screw, M4 x 8 Socket Head.....	6600-0707-408
2. Washer, M4 Split Ring.....	6600-0713-403
3. Washer, M4 Flat.....	6600-0712-403
4. Retaining Frame.....	6600-1288-500
5. Patient Probe Connector Plate.....	6600-1287-502
Patient Probe Label*	6600-2325-102
Strain relief nut	6600-0884-400
6. Compartment Air Probe Connector Plate	6600-1287-506
Compartment Air Probe Label*	6600-2325-109
7. Scale Wire Harness	6600-0728-700
Scale connector plate	6600-1287-504
Scale label.....	6600-2325-104
Dust cover.....	6600-1195-600
8. Blank Connector Plate.....	6600-1287-501
Blank Label.....	6600-2325-101
9. Patient Probe 1 Panel Harness.....	6600-0716-701
10. Patient Probe 2 Panel Harness.....	6600-0716-702
11. Probe Panel Housing	6600-0279-850
12. Rocker Switch Assembly	6600-0227-850
Power Switch and Battery Wire Harness	6600-0707-700
Switch Mounting Plate	6600-1844-500
Switch Plate Label*.....	6600-2325-108
14. Battery holder with adhesive	M1049264
15. Battery†.....	6600-1024-600

*Refer to section "6.3 Labels".

†Battery is a 7 cell, 8.4v Nickel Metal Hydride battery.

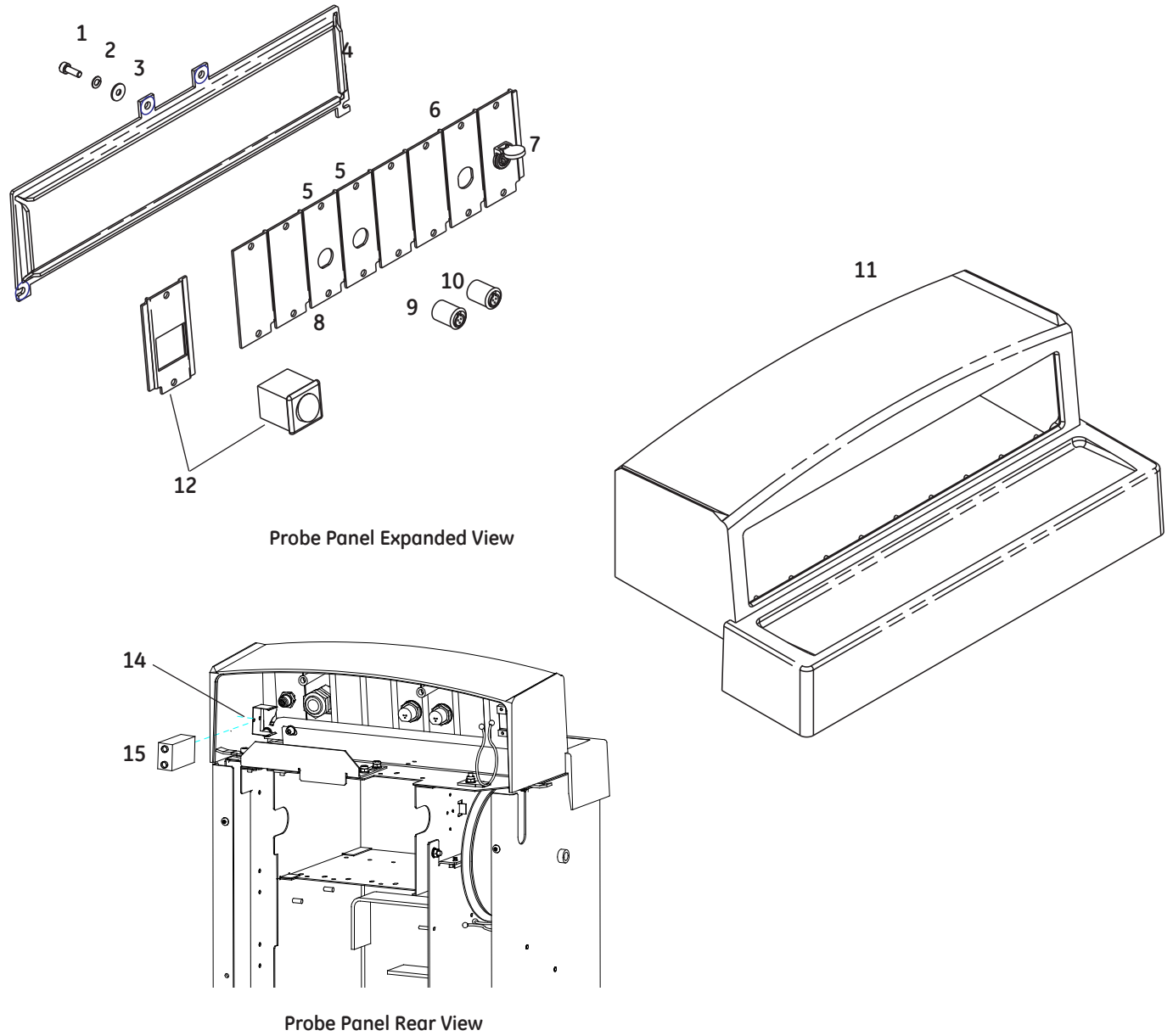

Figure 6-1 Probe Panel Assembly

1. Rear Cover	6600-1134-500
2. Screw, M3 x 8 Button Head.....	6600-0706-405
3. Washer, M3 Split Ring.....	6600-0713-402
4. Washer, M3 Flat.....	6600-0712-402
5. Standoff, M3 x 2.25"	6600-1070-400
6. PCA Display Driver	6600-0213-850
7. Standoff, M3 x 2.0"	6600-1068-400
8. EL Display Harness	6600-0725-700
9. EL Display	6600-0222-850
10. Round Spacer.....	6600-1191-400
11. Rotary Encoder Switch (includes cable, lock washer and nut).....	6600-1026-600
12. Display Cage*	6600-1133-500
13. Nut Plate.....	6600-1276-500
14. Touch Panel Assembly.....	6600-1007-600
15. Screw, M2.5 x 8 Socket Head	6600-0715-403
16. Alarm Lens.....	6600-1132-500
17. Right (east) Seal.....	6600-1736-501
18. Control knob.....	6600-1480-500
19. Power Fail Lens.....	6600-1065-400
20. Display Bezel.....	6600-1131-500
21. Left (west) Seal.....	6600-1736-502
22. Light Pipe.....	6600-1066-400
23. Washer, M4 Flat.....	6600-0712-403
24. Washer, M4 Split ring.....	6600-0713-403
25. Screw, M4 x 10 Socket Head	6600-0707-409
26. Nut, M3.....	6600-0711-403
27. PCA LED.....	6600-0215-850
28. LED Display Harness.....	6600-0739-700
29. Washer, M3 Internal lock	6600-0713-431

*When replacing, must also order touch panel (6600-1007-600).

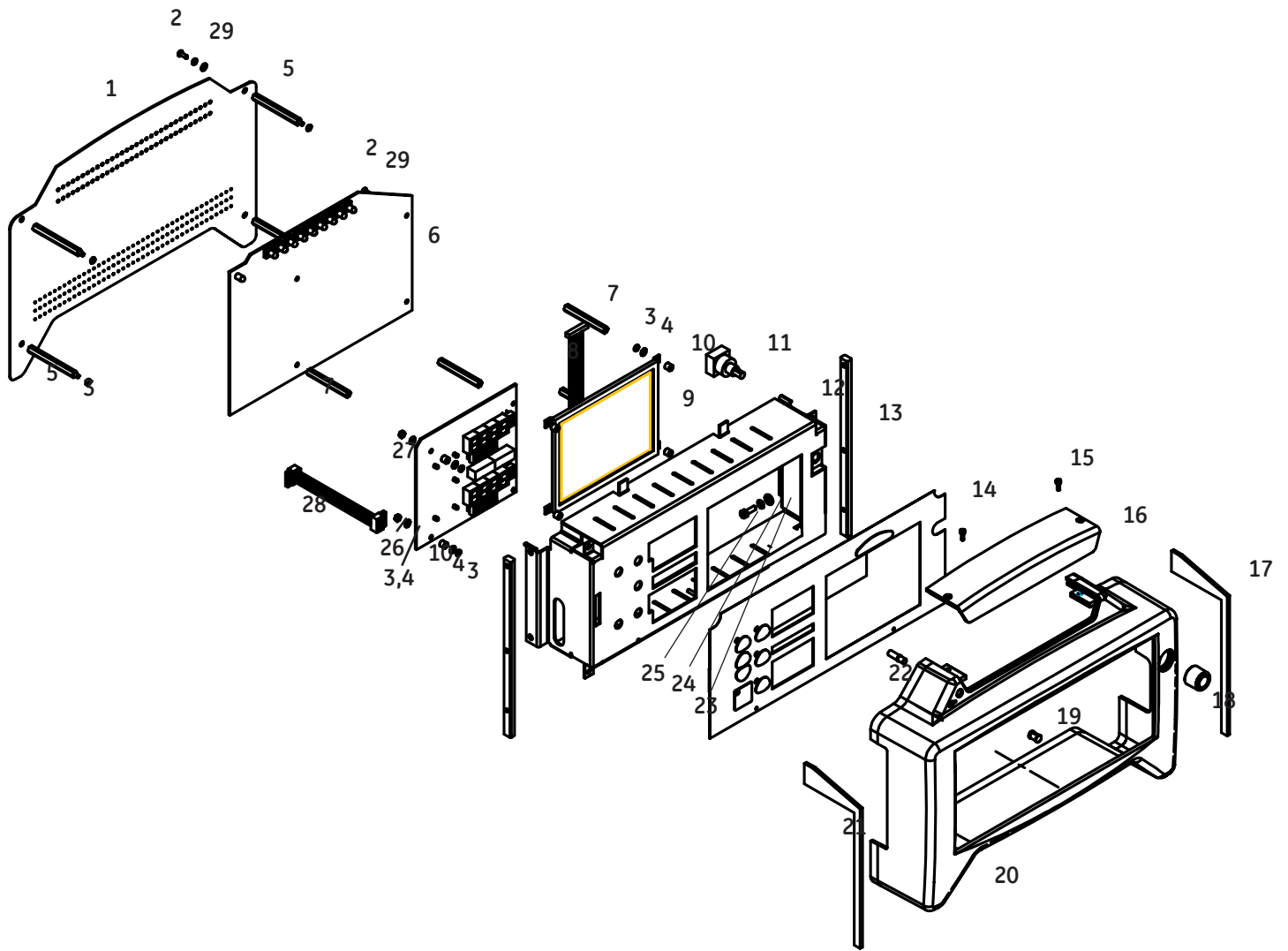
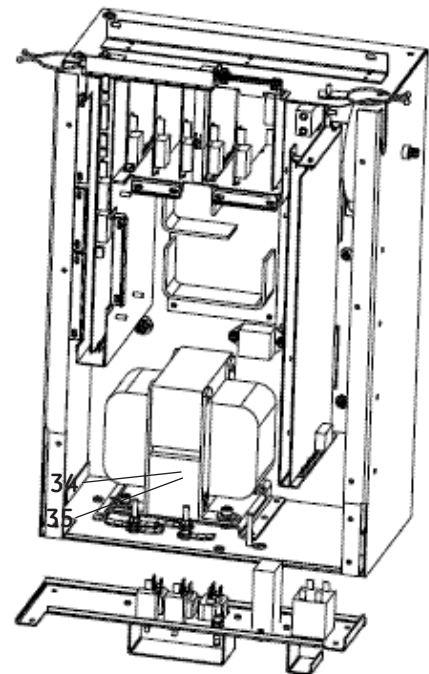

Figure 6-2 Display Module

1.	RS232 blank plate	6600-1752-500
2.	Cable twist lock	6600-1197-600
3.	Card cage.....	6600-1347-500
4.	In older units:	
	Battery (7 cell, 8.4v Nickel Metal Hydride).....	6600-1024-600
	Battery adapter harness.....	6600-0617-700
5.	Relay board bracket.....	6600-1166-500
6.	Relay board.....	6600-0214-850
	120 V 2 amp fuse (relay brd. 10 or higher).....	6600-0877-600
	230 V 1 amp fuse (relay brd. 10 or higher).....	6600-0882-600
	3.15 amp fuse (relay brd. 10 or higher).....	6600-0878-600
	Interface board@ (relay brd. 9 or lower).....	No longer needed.
	120V 2 amp fuse@	6600-1324-602
	230V 1 amp fuse@	6600-1324-601
7.	E-base/canopy transformer.....	6600-0746-700
8.	Screw, 5/16-18 x 2 ½.....	6600-1111-400
9a.	Incubator heater solid state relay	6600-1003-600
9b.	Radiant heater solid state relay	6600-1003-600
10.	Screw, M6 x 16.....	6600-0707-421
11.	Star washer, M6 internal tooth.....	6600-0713-434
12.	Flat washer, M6.....	6600-0712-405
13.	Star washer, M6 external tooth.....	6600-0713-445
14.	Wire shield	6600-1798-500
15.	Radiant heater transformer	6600-0815-700
16.	Power switch (115V).....	6600-1014-602
	Power switch (230V).....	6600-1014-601
17.	Line filter.....	6600-1006-600
18.	Single plug guard	
	U.S.,U.K., Italian, Swiss, Australian (short).....	6600-1701-500
	C.E. cord (long).....	6600-1857-500
	Bumper kit for power cord (40 bumpers).....	M1135907
19.	Accessories plug guard.....	6600-1711-500
20.	Flat washer, M4.....	6600-0712-403
21.	Lock washer, M4 internal tooth.....	6600-0713-432
22.	Screw, M4 x 8.....	6600-0706-408
23.	Washer, color code.....	6600-0338-400
24.	Plug ground.....	6600-0337-400
25.	Power outlet.....	6600-0583-600
26.	Connection panel.....	6600-1746-500
27.	Circuit breaker.....	6600-0562-603
28.	Nut, M6.....	6600-0340-400
29.	Lock washer.....	6600-0339-400
30.	Electrical enclosure	6600-1346-500
31.	Card tension rack (bottom)	6600-1064-400
32.	Control board	6600-0212-850
33.	Card guide (top).....	6600-1183-400
34.	Hex nut, M5.....	6600-0711-408
35.	Lock washer, M5.....	6600-0713-444
36.	Card guide (rear)	6600-1105-400
37.	Board retaining bracket	6600-1822-500
38.	M3 Nut for bracket.....	6600-0711-403
39.	Door hardware-	
	Screw, SEMS M4 x 10 BtnHd Skt.....	6600-0908-401



Parts not shown

Enclosure door.....6600-1349-500

Also refer to power cords in section "6.2 Accessories".

@ Not present on all units.

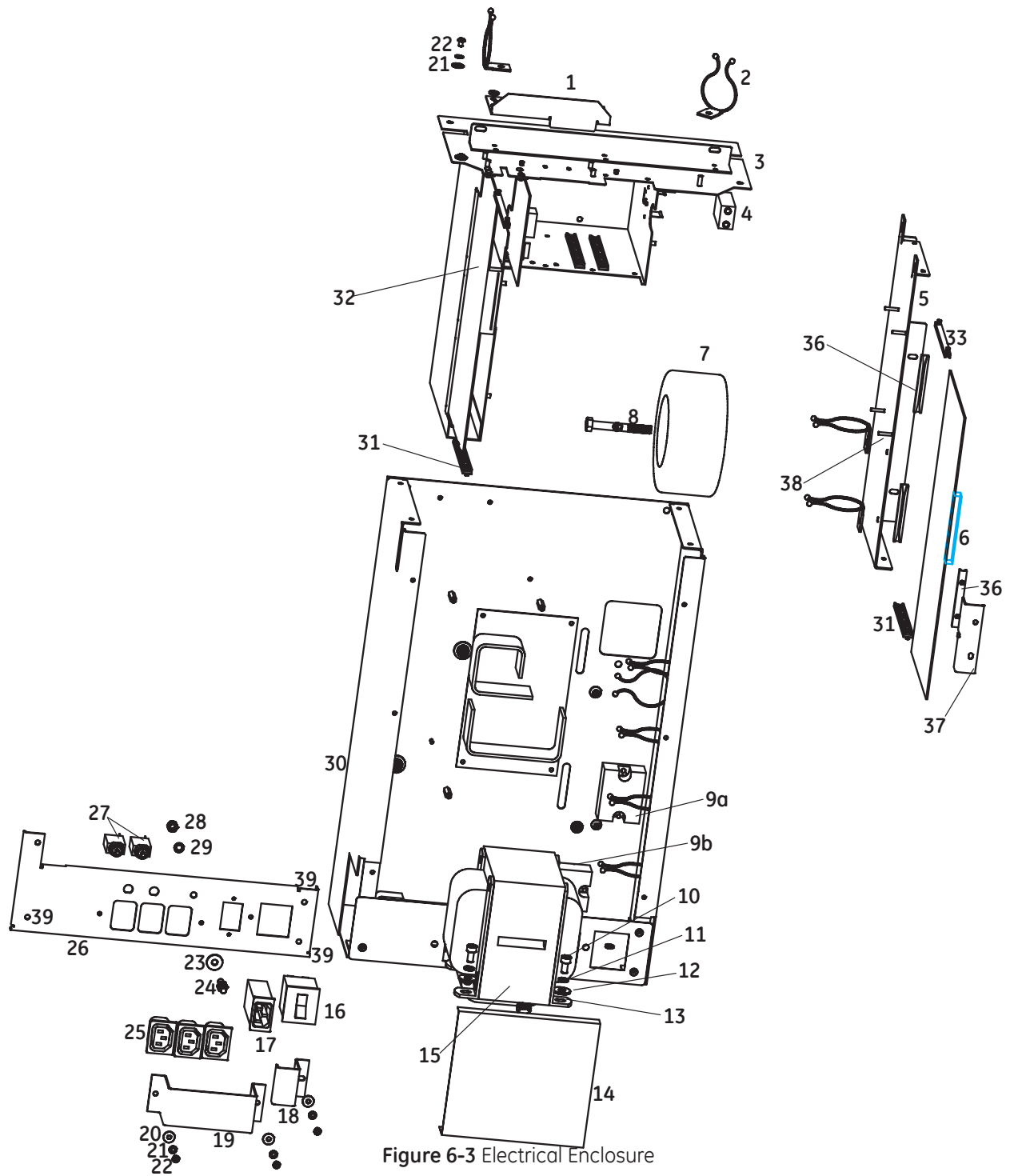

Figure 6-3 Electrical Enclosure

NOTE: If your battery is in the electrical enclosure above the relay board, order relocation kit M1045981. This kit includes parts and instructions to relocate the battery to the probe panel to reduce battery ambient temperature and prolong battery life.

1. Power supply*	6600-0221-850
2. Nut, M3.....	6600-0711-403
3. Star washer, M3.....	6600-0713-442
4. Nut, M4.....	6600-0711-407
5. Split ring washer, M4.....	6600-0713-403
6. Washer, M4.....	6600-0712-403
7. Humidifier isolation transformer.....	6600-1328-600
8. Spacer, M3 x 18.....	6600-1192-400
9. Screw, M6 skt. hd.....	6600-0707-420
10. Lock washer, M6 int. tooth.....	6600-0713-434
11. Mounting bracket.....	6600-1587-500
12. Washer, M4.....	0402-1133-300
13. Nylon lock nut, M4.....	6600-0714-402
14. Lock washer, M3 ext. tooth.....	6600-0713-442
15. Nylon lock nut, M3.....	6600-0714-401
16. Wire harness, ISO transformer.....	6600-1526-700
17. Screw, M4 x 6.....	6600-0706-407
18. Lock washer, M4 int. tooth.....	6600-0713-432
19. Cable twist lock.....	6600-1197-600
20. RS232 chassis.....	6600-1479-500
21. Screw lock, female.....	6600-0673-400
22. Retaining clip.....	6600-0672-400
23. Wire harness (with 9 pin D connector).....	6600-1531-700
24. RS232 ThermaLink PC board.....	M1059915
RS232 upgrade kit.....	6600-0257-850
25. Wire harness (connects to Control PCB).....	6600-1530-700

*The fuses on the power supply cannot be replaced. If the fuses are open there will be component damage that necessitates replacing the entire power supply.

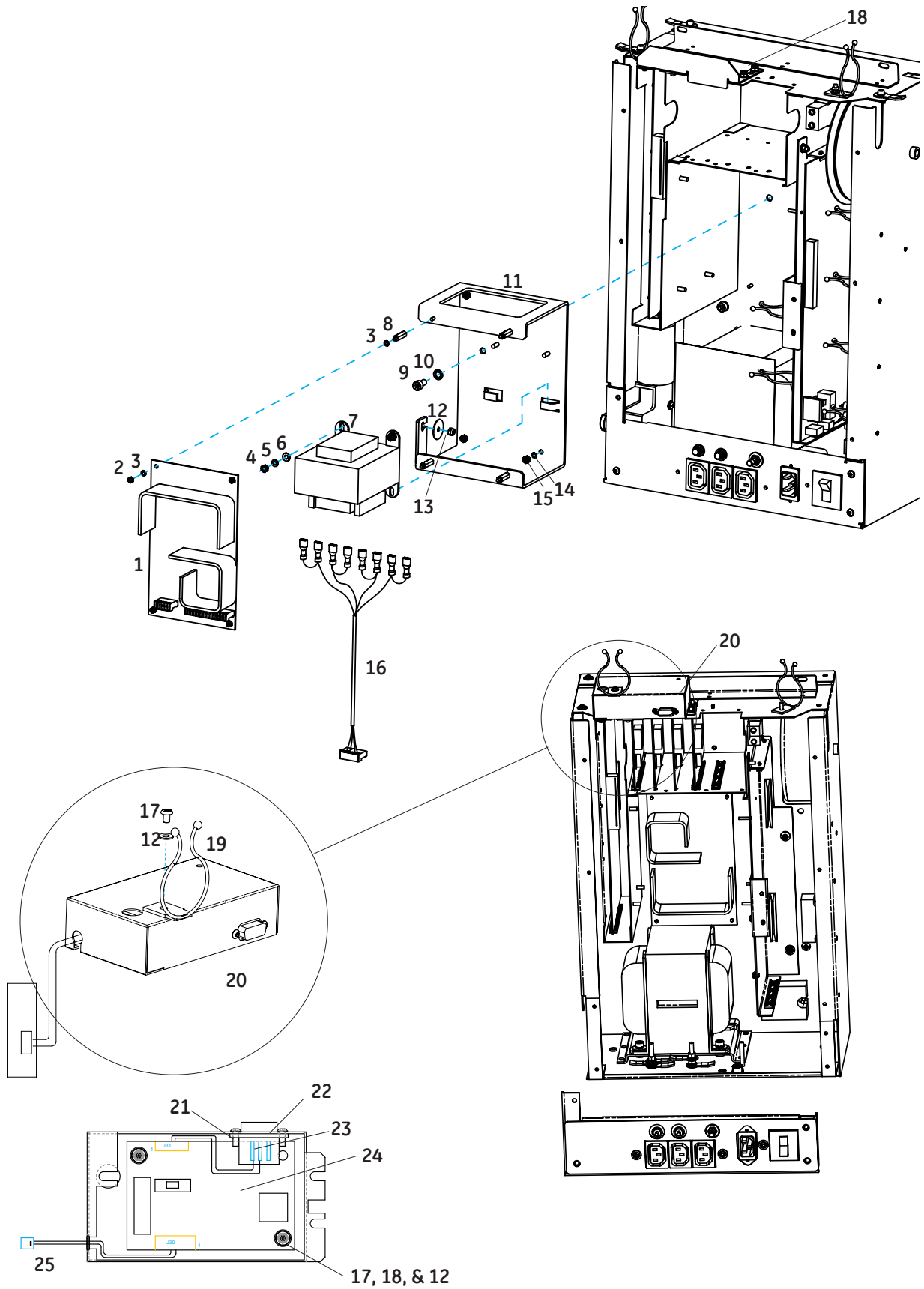

Figure 6-4 Humidifier Transformer and RS232 Option

6.1.2 Bed and Side Panels

- | | |
|--|---------------|
| 1. Giraffe pressure-diffusing mattress (blue)..... | 6600-0689-800 |
| Mattress (white)..... | 6600-1116-500 |
| 2. Clear Plate..... | 6600-1365-500 |
| 3. Rotating Bed..... | 6600-1353-500 |
| 4. Translation Deck..... | 6600-1352-500 |
| 5. Tape (5.4 in.) | 6600-1758-502 |
| 6. Latch Cover..... | 6600-1364-500 |
| 7. Locking Latch..... | 6600-1363-500 |
| 8. Spring..... | 6600-1079-400 |
| 9. Screw M4*..... | 6600-0706-409 |
| 10. Washer, M4 split ring* | 6600-0713-403 |
| 11. Washer, M4 flat*..... | 6600-0712-403 |
| 12. Tape (19.3 in.)..... | 6600-1758-501 |
| 13. X-ray Tray | 6600-1334-500 |
| 14. Tilt Ball and Screw Assembly | 6600-0814-700 |
| 15. Cover..... | 6600-1329-500 |
| 16. Top Plate..... | 6600-1328-500 |
| 17. Nut..... | 6600-1330-500 |
| 18. Plate..... | 6600-1457-500 |
| 19. Stop..... | 6600-1366-500 |
| 20. O-ring..... | 6600-1080-400 |
| 21. Tilt platform*@..... | 6600-1313-500 |
| 22. Washer*..... | 0202-4520-340 |
| 23. Spring*..... | 6600-1009-400 |
| 24. Brake bracket*..... | 6600-1225-500 |
| 25. Tilt Brake pad assembly*..... | 6600-0853-700 |
| 26. Knob*..... | 6600-1158-500 |
| 27. Cover*..... | 6600-1327-500 |
| 28. Slide*..... | 6600-1227-500 |
| 29. Spring*..... | 6600-1083-400 |
| 30. Ball bearing*..... | 6600-1228-500 |
| 31. Pin*@..... | 6600-2023-500 |
| 32. Pin retaining clip*@..... | 6600-0240-400 |
| 33. Plunger*..... | 6600-1325-500 |
| 34. Spring*..... | 6600-1043-400 |
| 35. Pan | 6600-0801-700 |
| 36. Screw, M4..... | 6600-0706-407 |
| 37. Rivet, small..... | 6600-1078-400 |
| 38. Rivet large..... | 6600-1203-400 |
| 39. Washer, brake*..... | 6600-1335-500 |

Parts not shown

Tilt Platform assembly (includes all items with*).....6600-0771-700

@New pin and retaining clip replaces earlier roll pin and fits platform without modifying the hole.

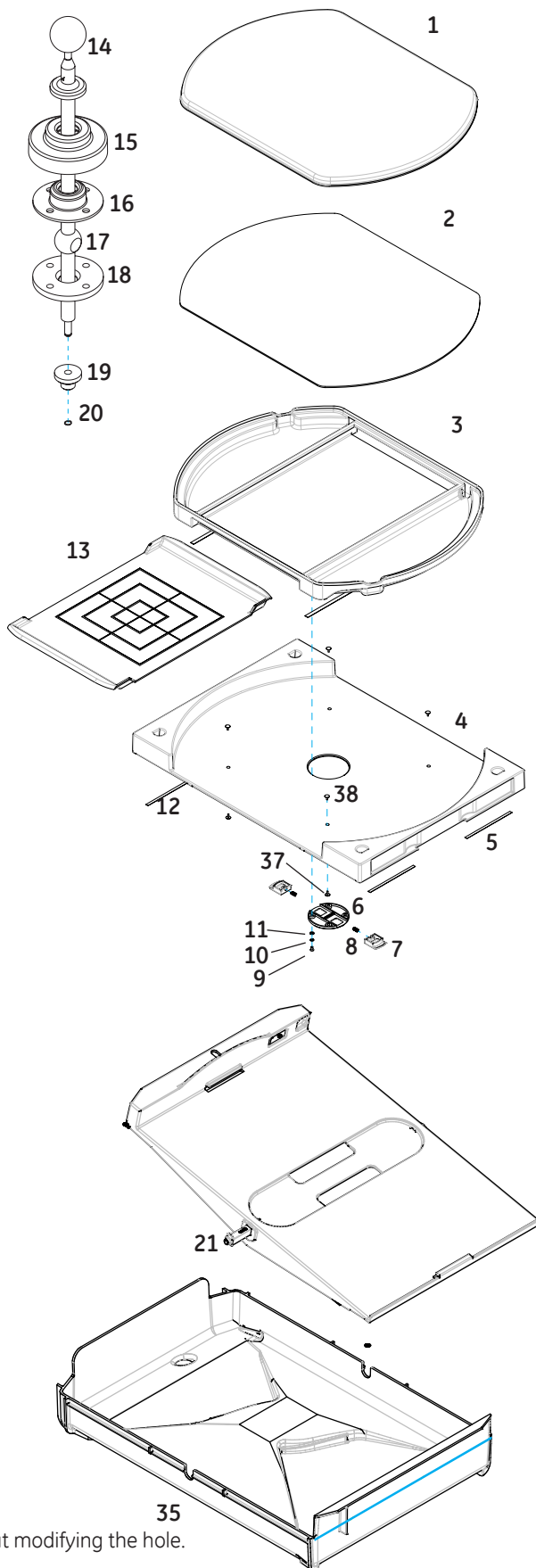
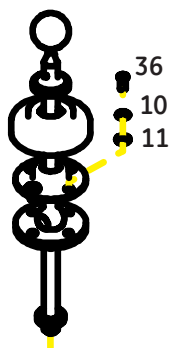

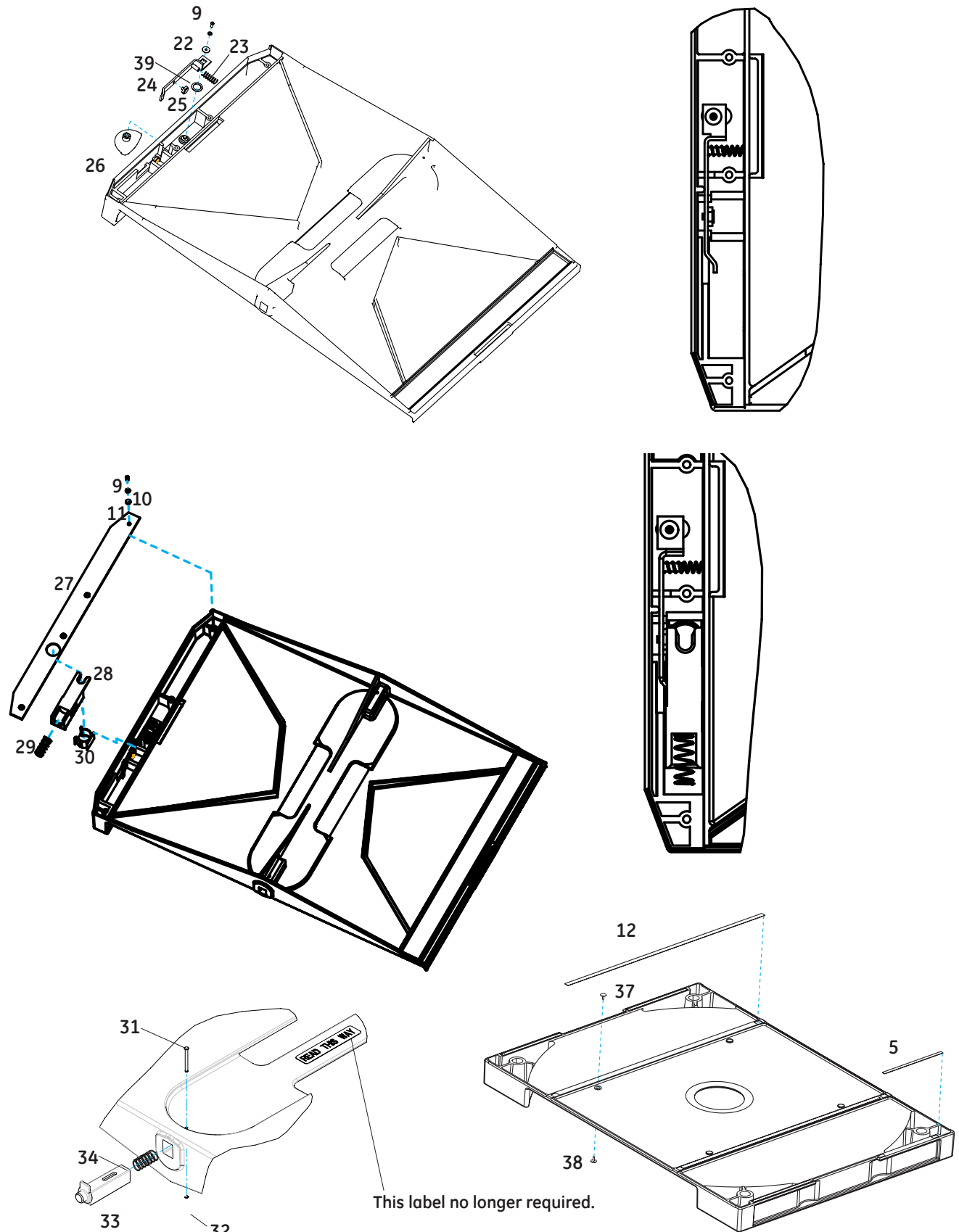

Figure 6-5 Bed

East/West Door Kit

(Does not include inner wall).....	6600-0134-850
1. Side wall with porthole cutouts.....	6600-1107-500
2. Inner wall.....	6600-1201-500
3. Porthole seal.....	6600-1249-500
4. Wall hinge snap.....	6600-1436-500
5. Side wall hinge.....	6600-1149-500
6. Side wall hinge mask label.....	6600-2321-100
7. Side wall inside latch cover.....	6600-1406-500
8. Porthole hinge bottom.....	6600-1239-500
9. Side wall latch.....	6600-1403-500
10. Screw, M2.9 x 9.5.....	6600-0709-409
11. Side wall latch spring.....	6600-1405-500
12. Side wall latch cover.....	6600-1404-500
13. Wall hinge snap post.....	6600-1429-500
14. Porthole hinge right (East) spring*.....	6600-1026-400
15. Porthole middle hinge.....	6600-1240-500
16. Hinge pin.....	6600-1041-400
17. Porthole hinge left (west) spring*.....	6600-1040-400
18. Flat washer.....	6600-0712-403
19. Split ring lock washer, M4.....	6600-0713-403
20. Screw, M4 x 16.....	6600-0706-411
21. Porthole hinge cover.....	6600-1242-500
22. Porthole door.....	6600-1238-500
23. Porthole latch cover*.....	6600-1246-500
24. Porthole latch spring.....	6600-1245-500
25. O-ring.....	6600-1049-400
26. Porthole latch base*.....	6600-1244-500
27. Plastic washer.....	6600-1050-400
28. Screw, M2.9.....	6600-0709-407
29. Porthole latch spacer.....	6600-1257-500
30. Screw, M4 x 12.....	6600-0706-410
31. Porthole Latch Assembly (Includes 23-28).....	6600-0738-700

Parts not shown:

Oscillator (High Freq. Vent) port cover.....	6600-0838-800
--	---------------

* Use Vac Kote (6700-0092-200) sparingly on the porthole door springs (items 14 and 16) and on the surfaces where the door latch pieces (items 23 and 26) slide together.

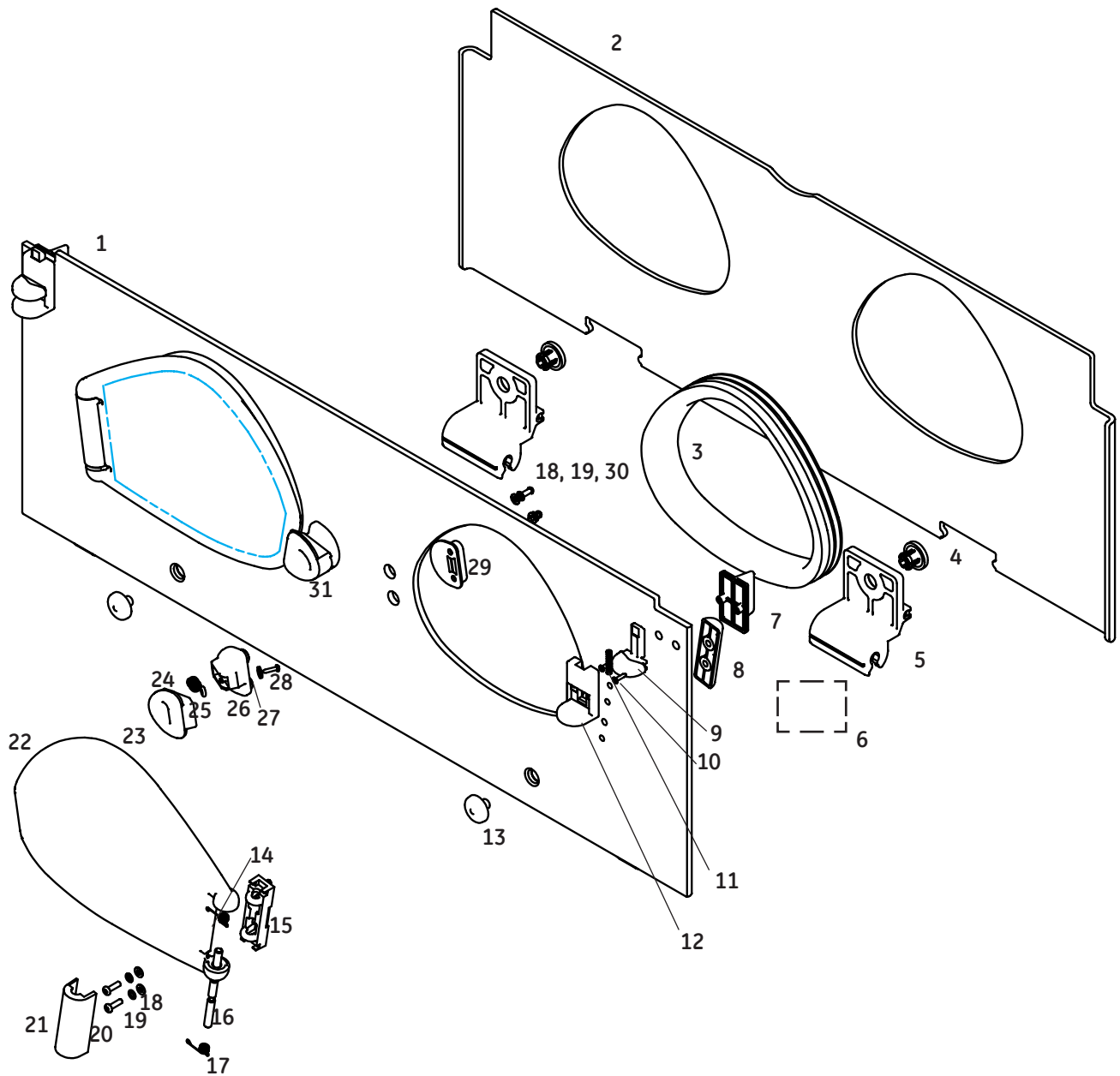
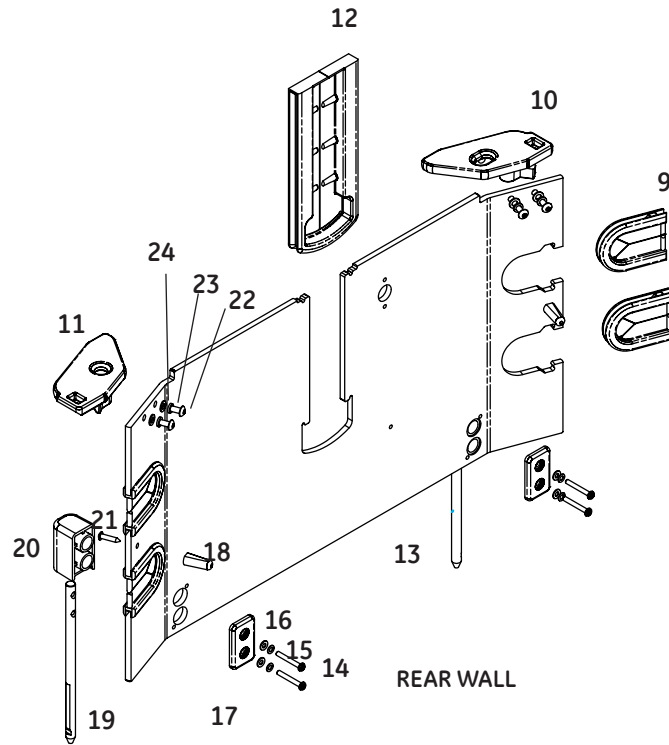

Figure 6-6 Side Panel (East/West)



- 1. Iris gasket.....6600-0699-500
- 2. Iris service kit.....6600-0037-850
- 3. (This item is no longer available.)
- 4. Right front (SE) wall hinge.....6600-1175-500
- 5. Wall hinge snap6600-1436-500
- 6. Left front (SW) wall hinge.....6600-1304-500
- 7. Hinge mask label.....6600-2320-100
- 8. Wall hinge snap post.....6600-1429-500
- 9. Corner grommet.....6600-1248-500
- 10. Front left/rear right (SW/NE) receptacle6600-1466-500
- 11. Front right/rear left (SE/NW) receptacle6600-1467-500
- 12. Ventilator slot grommet.....6600-1231-500
- 13. Rear (north) wall with grommet slot.....6600-1109-500
- 14. Screw, M4 x 30 Button Head.....6600-0706-414
- 15. Lock washer.....6600-0713-403
- 16. Flat washer.....6600-0712-403
- 17. Rear (north) wall mount cover.....6600-1305-500
- 18. Bumper.....6600-1485-500
- 19. Rear (north) wall mount rod.....6600-1356-500
- 20. Rear (north) wall mount6600-1428-500
- 21. Screw, M4.2 x 19 Pan Head.....6600-0709-404
- 22. Screw, M5 x 12 Button Head.....6600-0706-418
- 23. Lock washer.....6600-0713-404
- 24. Flat washer.....6600-0712-404
- 25. Front (south) wall solid6600-0247-852
- 26. Front (south) wall with ventilator cut out6600-0247-854
- 27. Front (south) wall with porthole cut out.....6600-0247-851
- 28. Front (south) wall with iris cut out.....6600-0247-853

Parts not shown:

- Oscillator (High Freq. Vent) port cover.....6600-0838-800

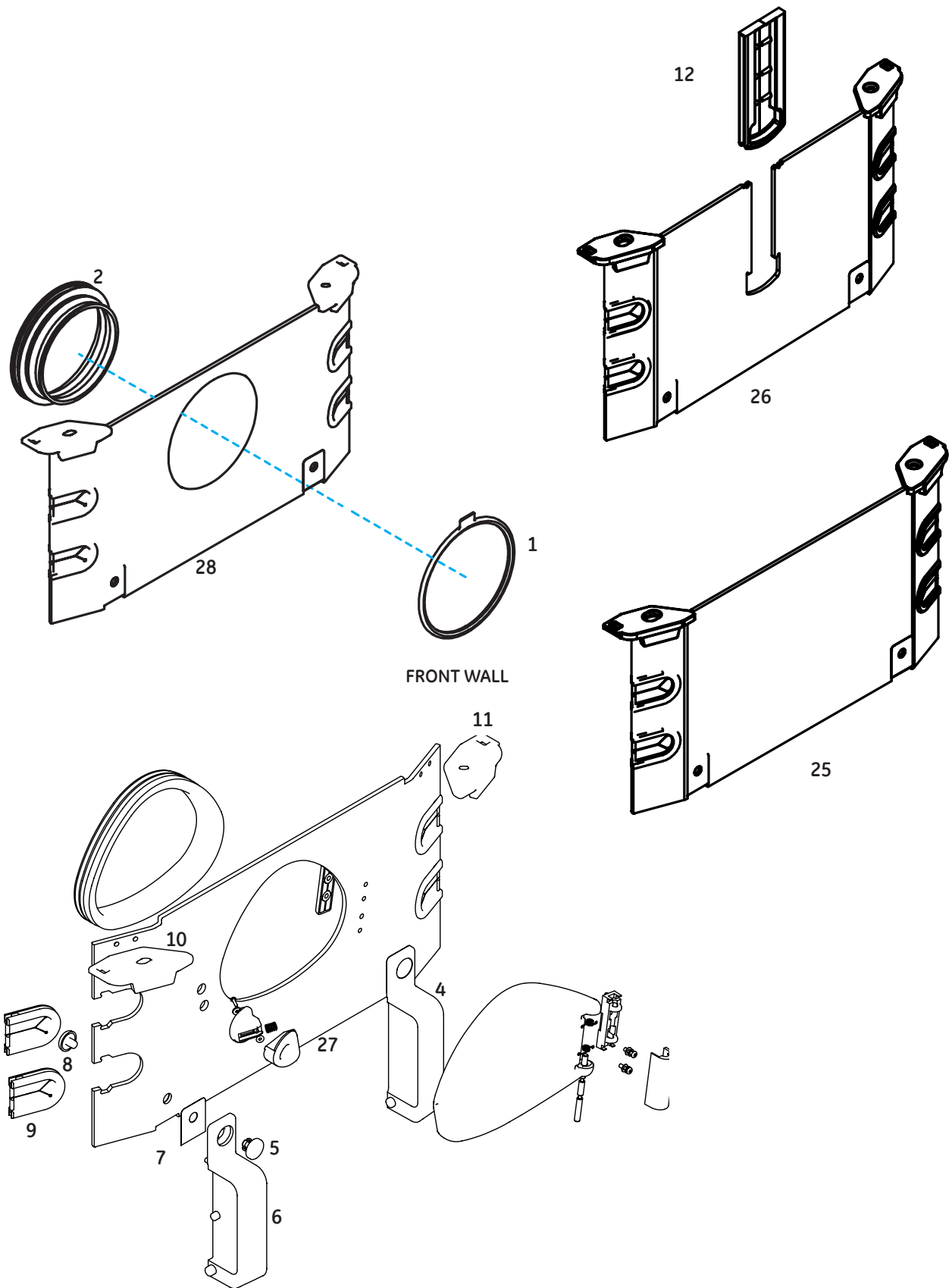
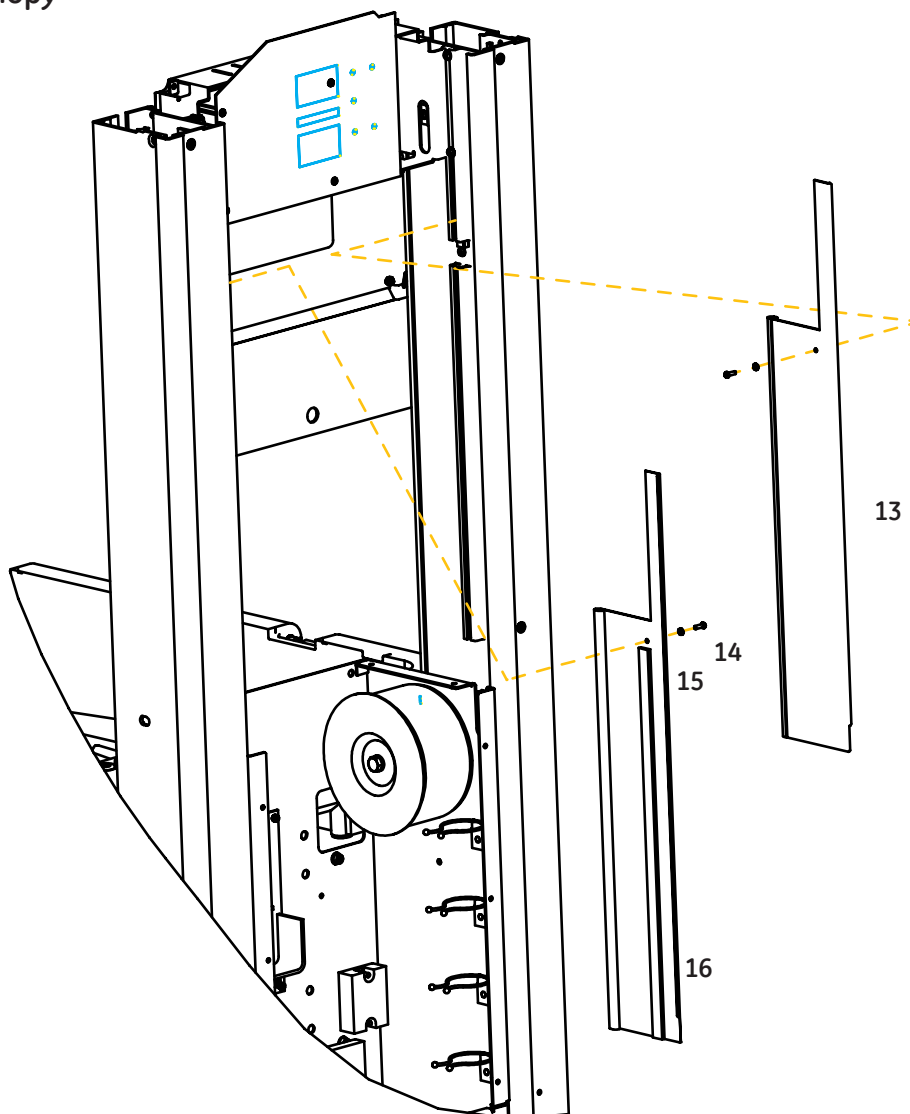

Figure 6-7 Rear (North) and Front (South) Wall

6.1.3 Radiant Heater and Canopy



- | | |
|---|---------------|
| 1. Top Plate..... | 6600-1421-500 |
| 2. Radiant Heater Housing..... | 6600-1308-500 |
| 3. Reflector..... | 6600-1281-500 |
| 4. Screw, M3 x 6 Socket Head..... | 6600-0707-401 |
| 5. Radiant Heater Assembly, 480 Watts..... | 6600-0220-850 |
| 6. Heater Guard Assembly (includes 7) | 6600-0219-850 |
| 7. Warning label..... | 6600-2328-101 |
| 8. Lock Washer M3 | 6600-0713-402 |
| 9. Nut, M3..... | 6600-0711-403 |
| 10. Bushing | 6600-1120-400 |
| 11. Lock Washer..... | 6600-0713-403 |
| 12. Screw, M4 x 10 Button Head..... | 6600-0706-409 |
| 13. Wire cover, left (west)..... | 6600-0824-700 |
| 14. Screw, M3 x 10 Button Head..... | 6600-0706-401 |
| 15. Star washer, M3 internal tooth..... | 6600-0713-431 |
| 16. Wire cover, right (East)..... | 6600-0823-700 |
| 17. Flat washer, M-3..... | 6600-0712-402 |

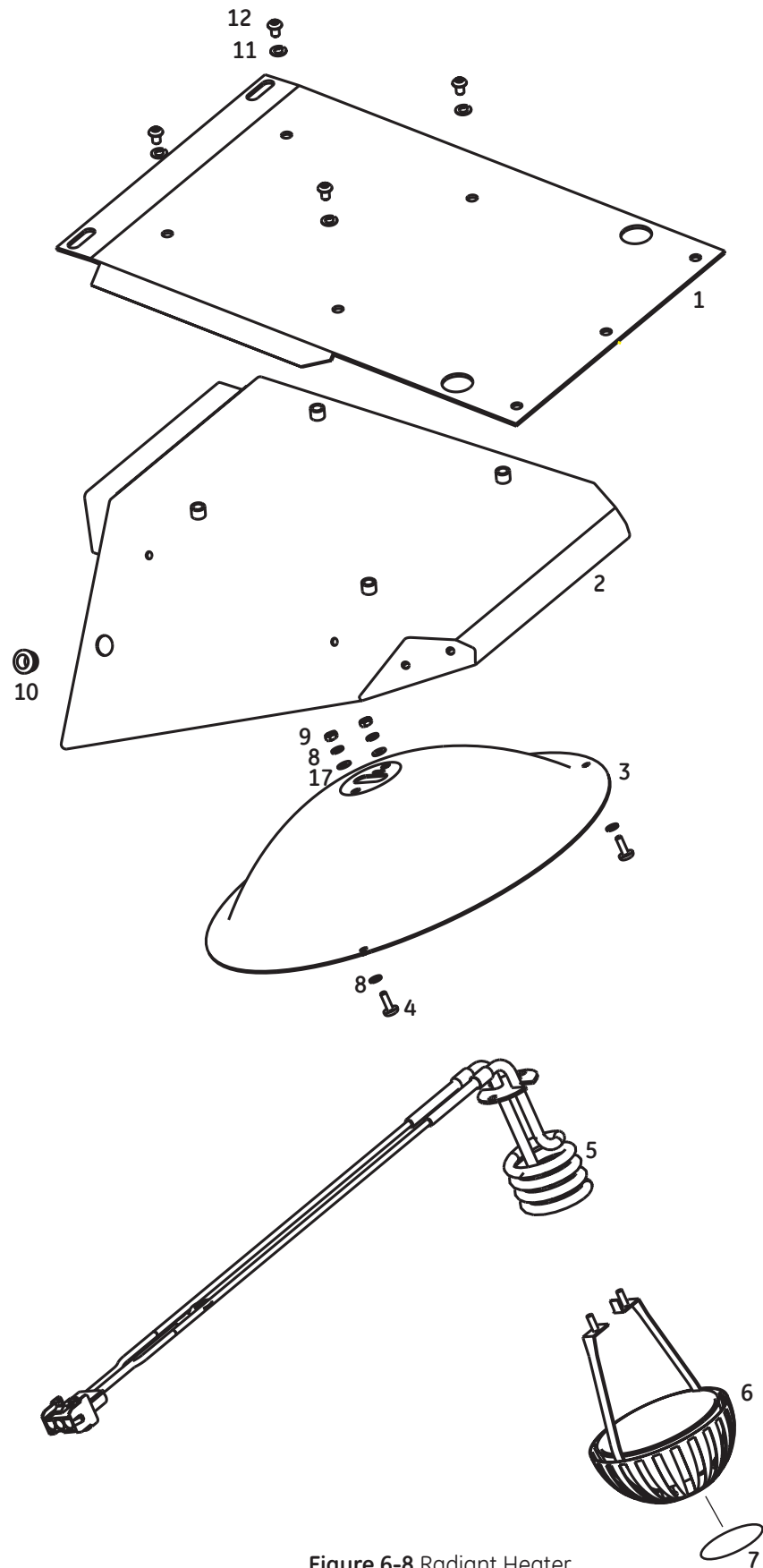
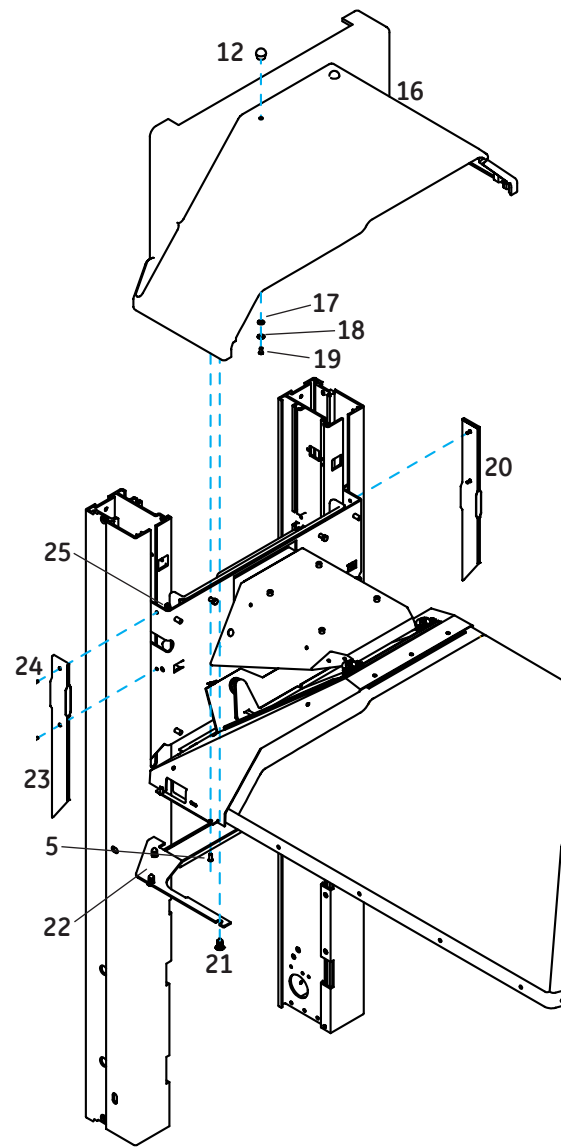

Figure 6-8 Radiant Heater

1. Radiant heater bracket.....	6600-1307-500
2. Bolt, M6 x 12.....	6600-0707-481
3. Nut, M6 x 12.....	6600-0711-460
4. Heater doors spring spool assembly (includes cable)	6600-0857-700
Heater door cable.....	6600-0817-700
5. Screw, M4 x 10 button.....	6600-0706-409
6. Split ring lock washer	6600-0713-403
7. Screw, M4 x 12 socket head cap.....	6600-0707-410
8. Nut, elastic lock, M5 x 0.8.....	6600-0714-403
9. Nut	6600-1165-400
10. Canopy.....	M1078118
11. Nut, elastic lock, M4 x 0.7.....	6600-0714-402
12. Hood button.....	6600-1788-500
13. Cable clamp.....	6600-1060-400
14. Hex nut, M4.....	6600-0711-407
15. Star washer, M4.....	6600-0713-443
16. Heater housing cover.....	6600-1220-500
17. Flat washer, M5.....	6600-0712-404
18. Split ring lock washer, M5.....	6600-0713-404
19. Screw, M5 x 12 Button head socket.....	6600-0706-418
20. Inside cover, right	6600-1459-500
21. Soffit clip, arrow fastener.....	6600-1056-400
22. Soffit.....	6600-1461-500
23. Inside cover, left (west).....	6600-1477-500
24. Screw, M3 x 10 socket head.....	6600-0706-401
25. Lock nut, M3.....	6600-0714-401
26. Back plate bracket.....	6600-1306-500
27. Shoulder Screw, M4 x 6.....	6600-1201-400
28. Door.....	6600-1460-500
29. Spring.....	6600-1109-400
30. Screw, M3 x 20 button head.....	6600-0706-404
31. Split ring washer, M3.....	6600-0713-402
32. Spacer.....	6600-1149-400



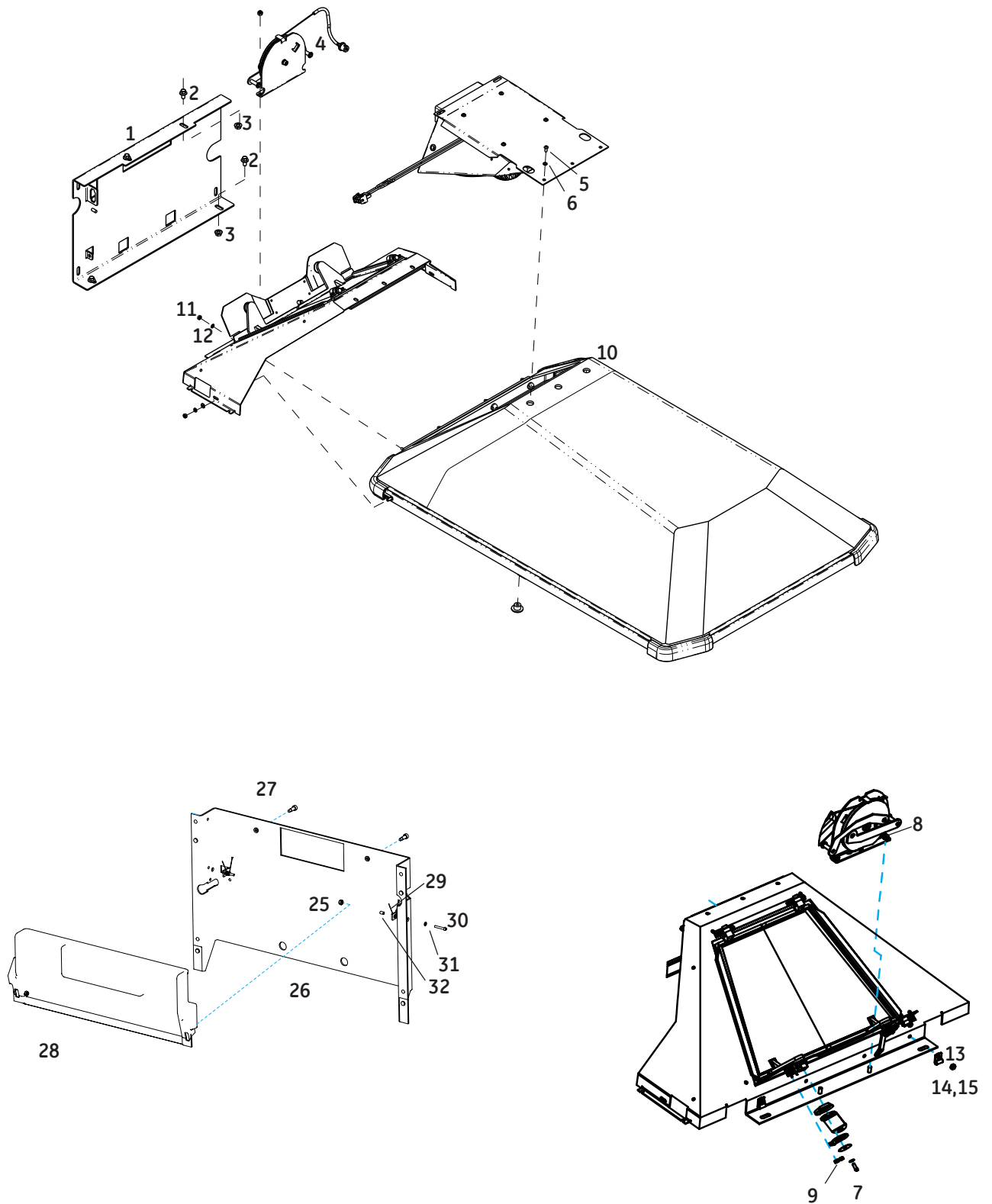

Figure 6-9 Canopy

Parts for original canopy seals:

1. Screw, M4 x 12, Socket Hd Cap.....	6600-0707-410
2. Split ring lock washer	6600-0713-403
3. Threaded insert.....	6600-1274-500
4. Inner side extrusion@.....	6600-1002-400
5. Inner front/rear extrusion@.....	6600-1003-400
6. Flat washer, M4.....	6600-0712-403
7. Screw, M4 x 12 socket head cap.....	6600-0707-410
8. Canopy*.....	M1078118
9. Left canopy seal, side (west)@.....	6600-1865-501
10. Label.....	6600-2358-100
11. Corner flange, front right/rear left (SE/NW).....	6600-0272-850
12. Canopy seal, front (south)@.....	6600-1865-502
13. Corner flange, front left/rear right (SW/NE).....	6600-0275-850
14. Canopy corner pin@.....	6600-1197-500
15. Screw, M4x0.7x16 Flhd Nylok	6600-1155-400
16. Right canopy seal, side (east)@.....	6600-1865-503
17. Door support	6600-1471-500
18. Nut, elastic lock, M4 x 0.7.....	6600-0714-402
19. Spacer, 10 mm x 8.0@.....	6600-1108-400
20. Set screw, M4 30 socket head cup point.....	6600-0715-407
21. Rear (north) canopy seal@.....	6600-1865-504
22. Spacer, M4 x 8L.....	6600-1220-400

* When replacing canopy, order item 10, or order enhanced canopy seals retrofit kit number M1208286.

@ If replacing these parts, order enhanced canopy seals retrofit kit number M1208286.

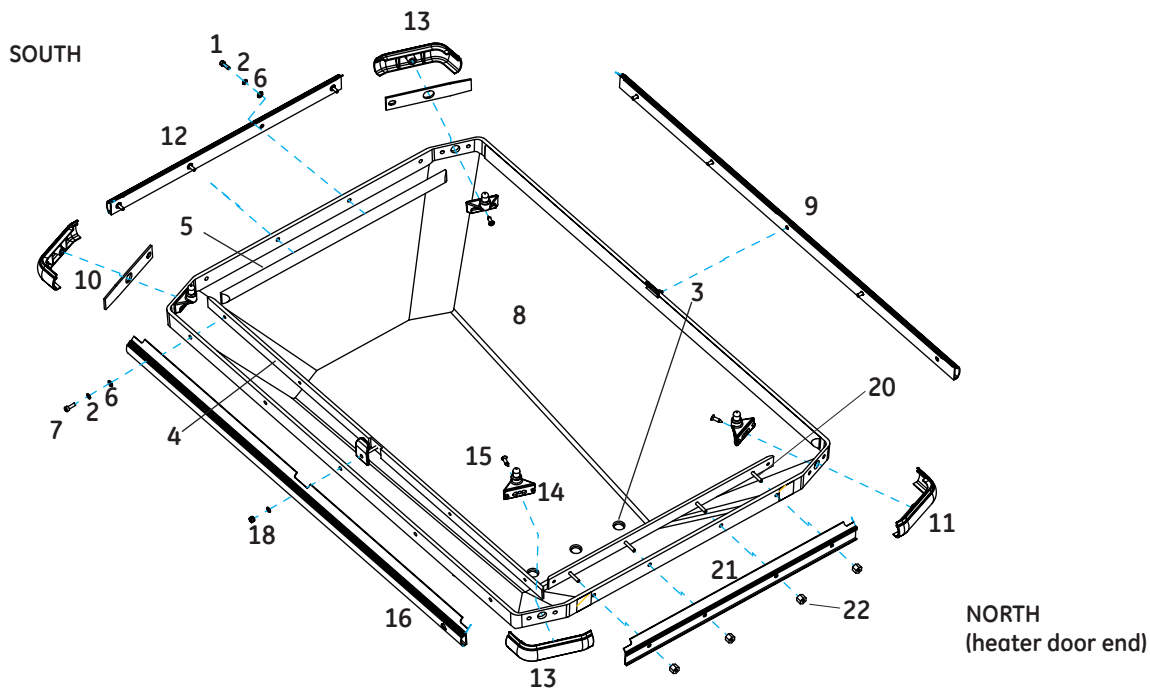

Figure 6-10 Original Canopy Seal Parts

Kits for enhanced canopy seals:

Seal Replacement Kit (contains the following parts)	M1208284
1. West Canopy Seal.....	M1156919
2. South Canopy Seal.....	M1156921
3. East Canopy Seal.....	M1156923
4. North Canopy Seal.....	M1156925
Corner Cover Replacement Kit (contains the following parts)	M1208283
5. Corner Cover SE	M1156938
6. Corner Cover SW	M1156942
7. Corner Cover Receiver	M1156944
8. M4 x 16 Flathead Phillips Screw with Pre-applied Nylon Patch.....	6600-1155-400
Hardware Replacement Kit (contains the following parts)	M1208285
8. M4 x 16 Flathead Phillips Screw with Pre-applied Nylon Patch.....	6600-1155-400
9. West Canopy Rail	M1156929
10. South Canopy Rail.....	M1156933
11. East Canopy Rail	M1156927
12. North Canopy Spacer.....	M1156935
13. Rail Spacer (thicker than spacer washer M1156954).....	6600-0521-400
14. Flange Corner NW.....	6600-1343-500
15. Flange Corner NE.....	6600-1344-500
16. Canopy Corner Pin.....	M1164256
17. Canopy Corner Pin Gasket.....	M1156952
18. Door Support.....	6600-1471-500
19. Door Support Gasket.....	M1156948
20. Spacer Washer.....	M1156954
21. Smooth Nut.....	M1156957
22. M4 x 20 Buttonhead Socket Cap Screw.....	6600-0706-412
23. M4 x 16 Buttonhead Socket Cap Screw.....	6600-0706-411
24. M4 x 30 Socket Set Screw Cup Point Stainless Steel.....	6600-0715-407
25. M4 x 4.1 id 0.9 Thick Splitlock Washer.....	6600-0713-403
M4 Hex Nut Stainless Steel	6600-0711-407
M4 x 4.3 id 0.5 Star Washer External	6600-0713-443
M4 x 12 Buttonhead Stainless Steel Screw	6600-0706-410
M4 x 4.3 id 0.8 Flat Washer.....	6600-0712-403
Retrofit Kit (contains all of the above parts)	M1208286

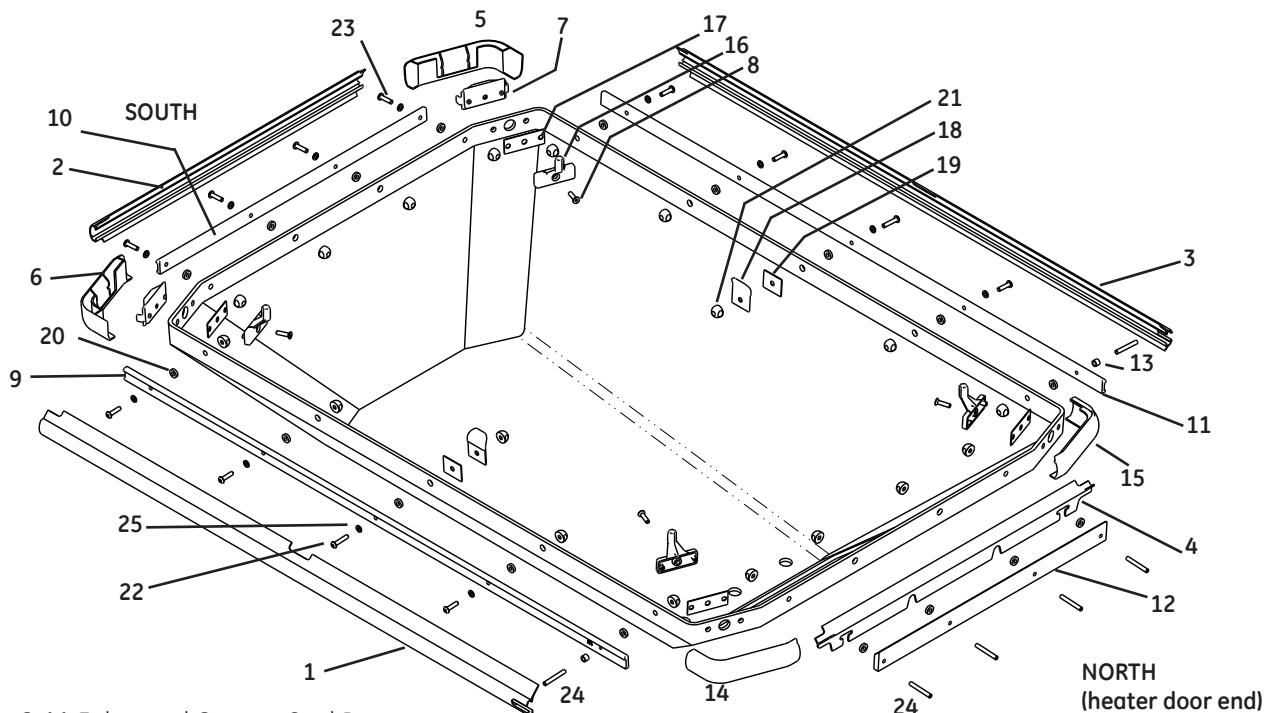

Figure 6-11 Enhanced Canopy Seal Parts

1. Foil door, right (East)*	6600-1454-500
2. Heater door, right (East)*	6600-1309-500
3. Foil door, left (west)*	6600-1453-500
4. Heater door, left (west)*	6600-1310-500
5. Lower pivot bearing	6600-1059-400
6. Elastic lock nut, M3	6600-0714-401
7. Spherical bearing block	6600-1058-400
8. Top bearing spacer	6600-1702-500
9. Interface bracket@	6600-1215-500
10. Shoulder screw, socket head	6600-1113-400
11. Washer	6600-1163-400
12. Top seal	6600-1709-500
13. Bottom seal	6600-1710-500
14. Gasket	6600-1396-500
15. Door switch	6600-1154-600
16. Locking nut, 2 -56	6600-1165-400
17. Cam spacer	6600-0925-400
18. Inner cam (white) with notch@	6600-1893-500
19. Outer cam (white) with notch@	6600-1892-500
20. Washer, .175 ID x .875 OD	0402-1133-300
21. Split ring washer	6600-0713-403
22. Screw, M4 x 10 button head	6600-0706-409

*Always order heater door and foil to install at the same time.

@ If replacing older black cams or white without notch order kit number 6600-0230-850 (includes item 9) and canopy seal kit 6600-0237-850. When replacing interface bracket, also replace washer, top seal, and bottom seal.

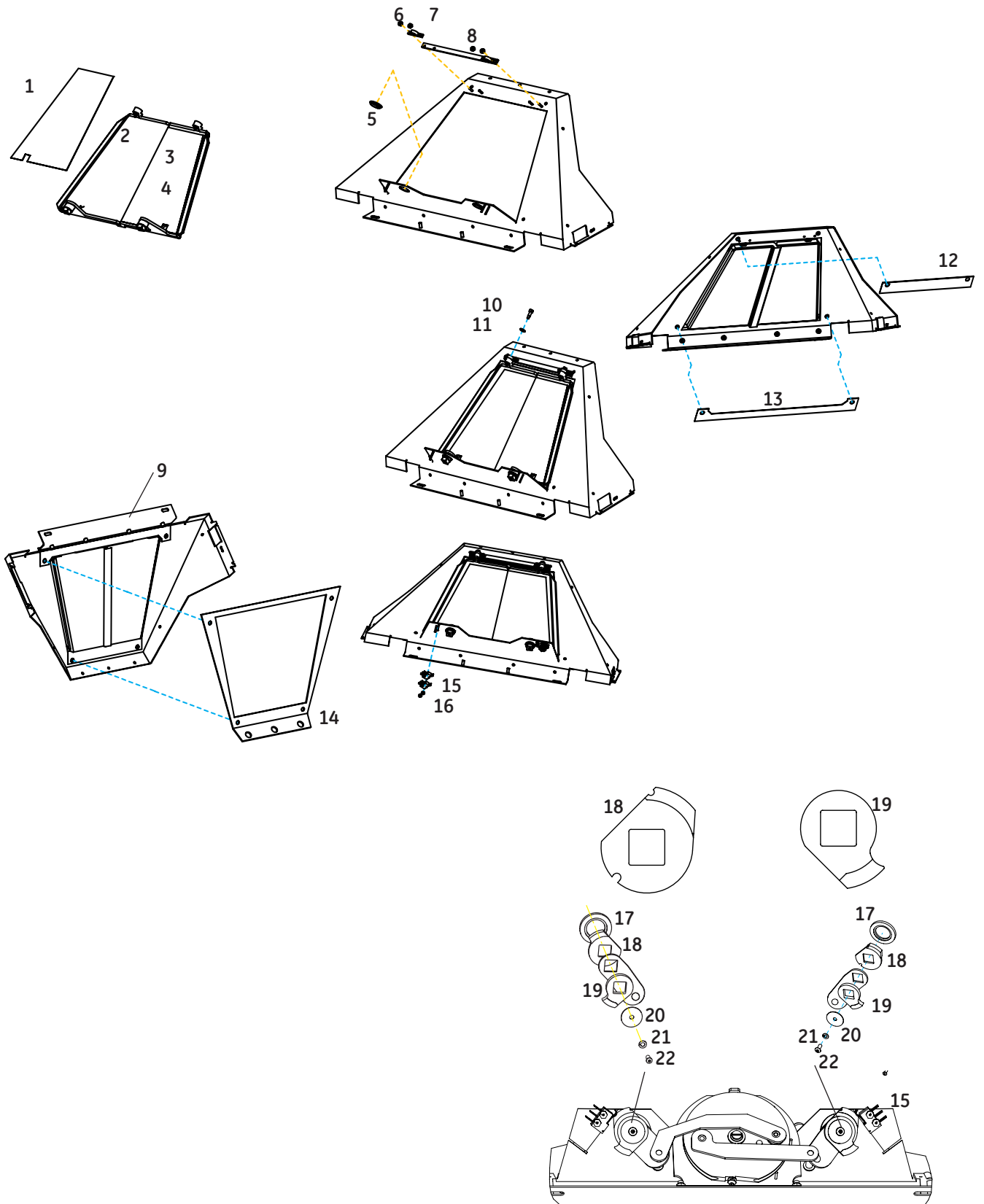

Figure 6-12 Heater Doors

6.1.4 Chassis

1. Fan seal.....	6600-1557-500
2. Fan.....	6600-1738-500
3. Fan hub.....	6600-1440-500
4. Heat sink*.....	6600-1858-500
5. Heat sink gasket.....	6600-0300-300
6. Canopy lift switch, left (east).....	6600-0736-701
7. Canopy lift switch, right (west).....	6600-0736-702
8. Hairpin.....	6600-1046-400
9. Tie down cylinder.....	6600-1331-500
10. Incubator heater and harness assembly*.....	6600-1041-700
Retaining clip.....	6600-1211-500

*If you have a silver colored heatsink with threaded heater cartridges, you must replace both the heatsink and the cartridges. Order kit number 6600-0228-850. Kit also includes new gasket and heater retaining clips.

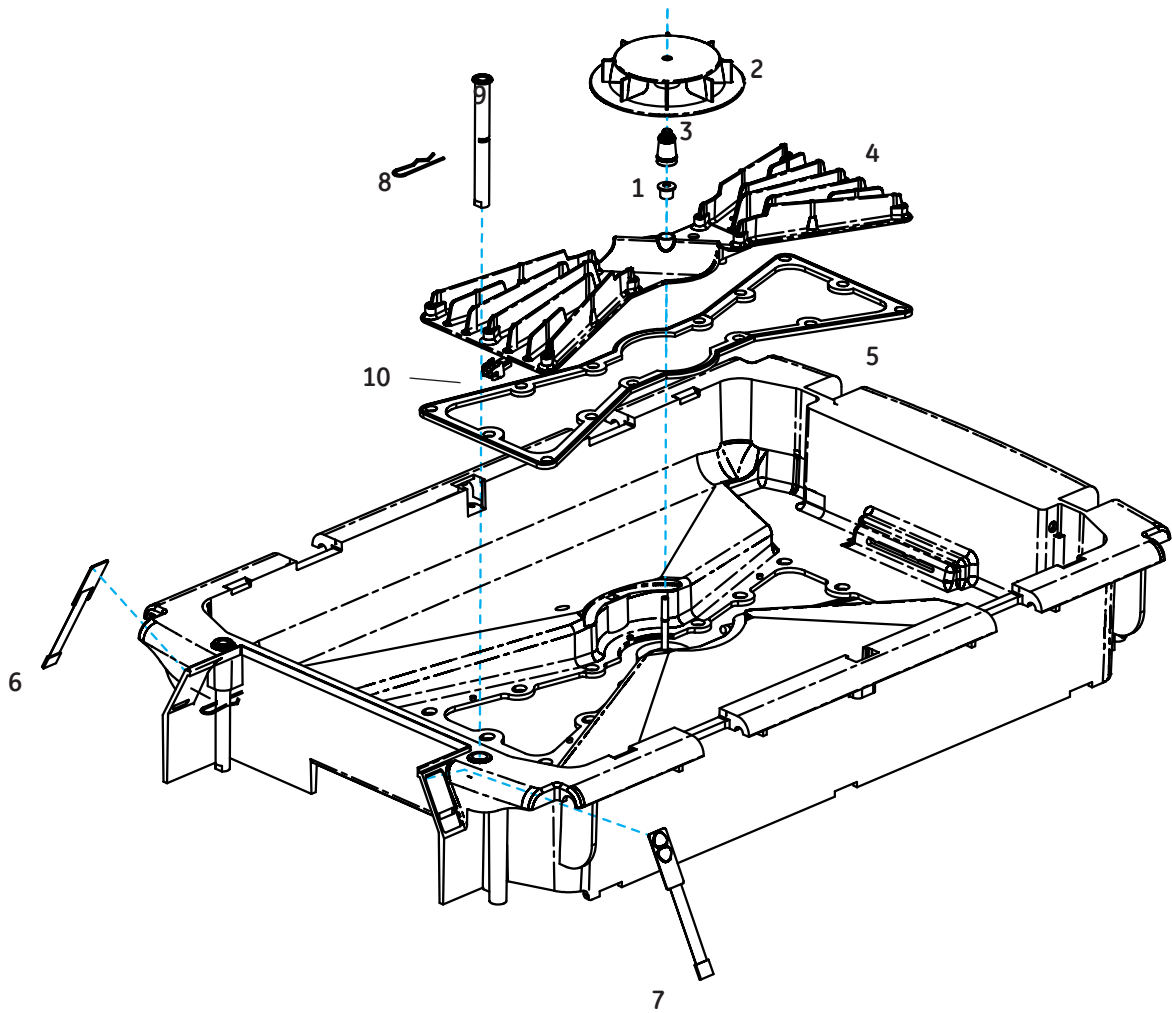
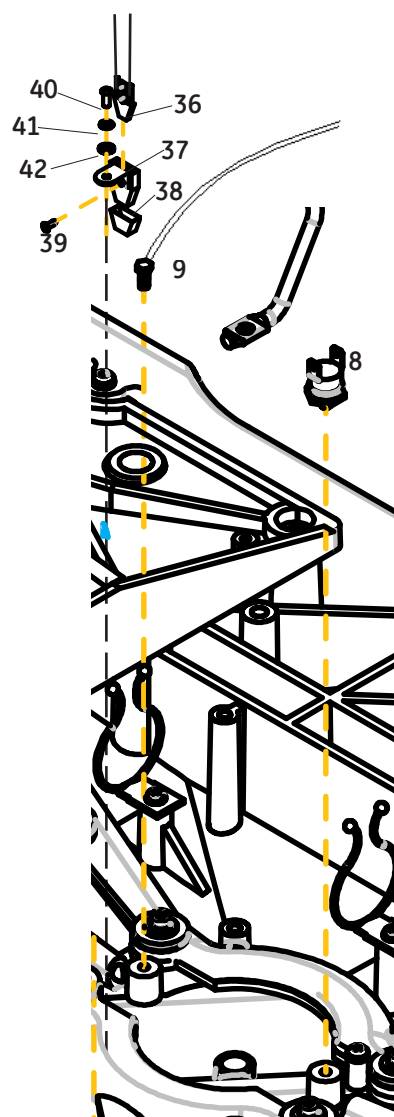

Figure 6-13 Upper Chassis

1.	Fan motor bracket.....	6600-1162-500
2.	Fan motor	6600-1057-600
	Fan.....	6600-1433-500
3.	Screw, M4 shoulder	6600-1051-400
4.	Flat washer, M5.....	6600-0712-409
5.	Motor mount.....	6600-1000-400
6.	Lock washer, M3.....	6600-0713-431
7.	Screw, M3 x 6.....	6600-0707-401
8.	Thermostat.....	6600-1019-600
9.	Heat sink sensor	6600-0226-850
10.	Screw, M5 x 25.....	6600-0707-418
11.	Split ring lock washer, M5	6600-0713-404
12.	Bushing.....	6600-1434-500
13.	Silicon washer.....	6600-1778-500
14.	Screw, M4 x 8.....	6600-0707-408
15.	Split ring lock washer, M4	6600-0713-403
16.	Flat washer, M4.....	6600-0712-446
17.	Wire routing clip.....	6600-1197-600
18.	Front Pleur-evac hanger (south).....	6600-1202-500
19.	Screw, M4 x 10.....	6600-0707-409
20.	Star washer, M4.....	6600-0713-443
21.	Split ring lock washer	6600-0713-403
22.	Knob	6600-0894-400
	Push washer	6600-0895-400
23.	Filter cover assy. (includes knob and washer).....	6600-1533-700
24.	Filter (10 pcs, behind the humidifier reservoir)	6600-0207-850
25.	Chassis*	6600-0278-850
26.	Bed pivot block.....	6600-1326-500
27.	Screw, M4 x 20.....	6600-0707-412
28.	Door hinge button.....	6600-1285-500
29.	E-clip.....	6600-1045-400
30.	Washer.....	6600-1100-400
31.	Pin stop.....	6600-1730-500
32.	Door spring.....	6600-1044-400
33.	Hinge pin	6600-1284-500
34.	Chassis side panel	6600-1280-500
35.	Screw, M5 x 12.....	6600-0706-418
36.	Optical fan sensor (includes wire harness).....	6600-0820-700
37.	Sensor holder.....	6600-1435-500
38.	Sensor gasket.....	6600-1437-500
39.	Screw, M2.9 x 6.5	6600-0709-405
40.	Screw, M3 x 6.....	6600-0707-401
41.	Split ring lock washer, M3	6600-0713-402
42.	Flat washer, M3.....	6600-0712-402
43.	Side Pleur-evac hanger (E/W).....	6600-1703-500
44.	Screw, M6 x 12, Btn. Hd.	6600-0706-427
45.	Wire raceway cover	6600-1303-500
46.	Screw, SEMS M4 x 6 BtnHd Skt.....	6600-0908-402
47.	Chassis cover	6600-1888-500
48.	Screw, shoulder	6600-1033-400
49.	Flat washer, M5.....	6600-0712-404
50.	Spring.....	6600-1299-500
51.	Spring clip	6600-1300-500
52.	Humidifier spacer.....	6600-1814-500
53.	Humidifier sound damper	6600-1494-500



54.	Screw, M3 x 6 button head	6600-0706-406
55.	Screw, captive M4 x 8.....	6600-0868-401
56.	Star washer, int. M4.....	6600-0713-432

Parts not shown

Socket plug (for servo-oxygen hole) .6600-1214-400

*Must order switch labels (6600-0736-701 and 6600-0736-702) items 6 and 7 on previous page when replacing chassis).

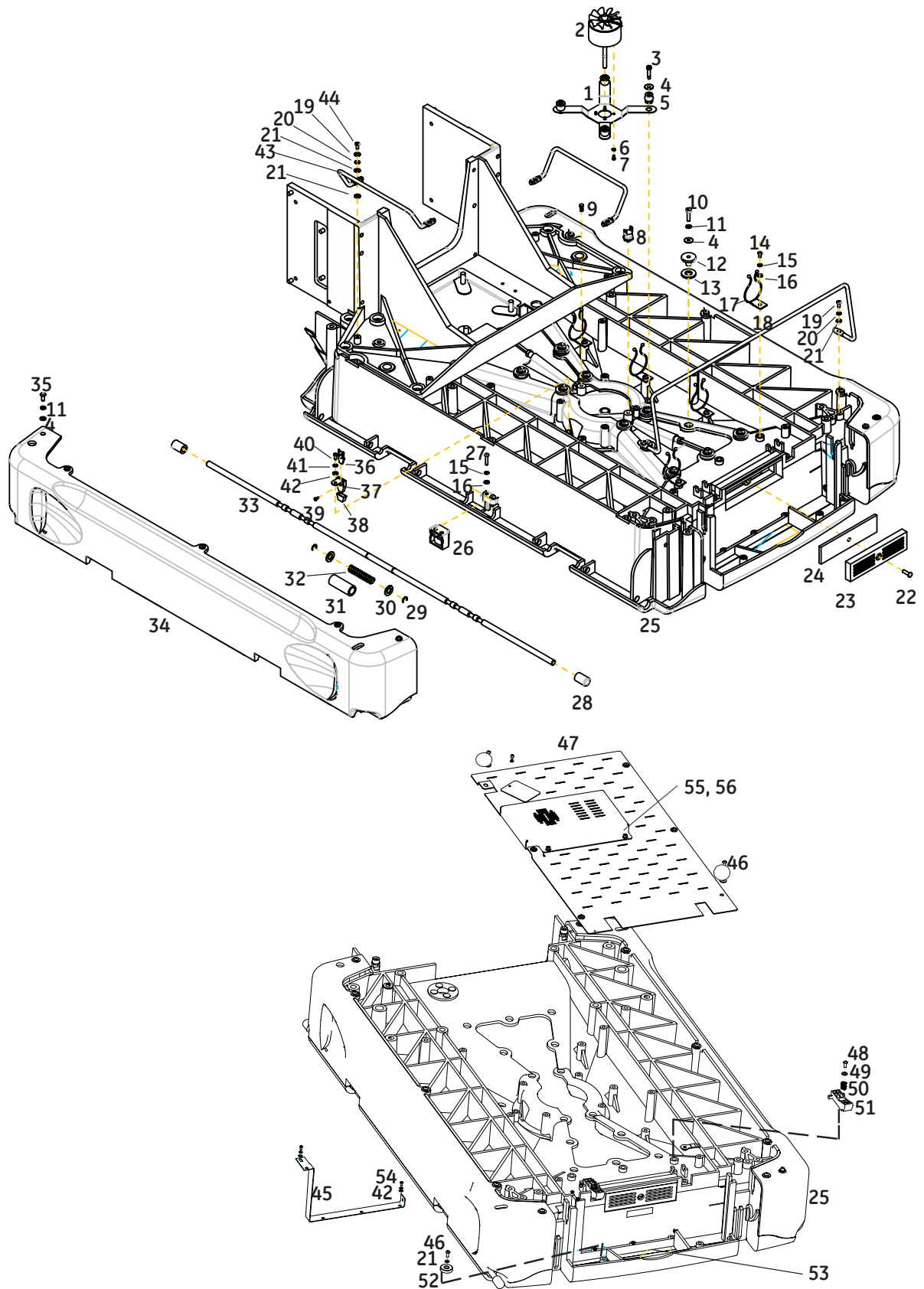

Figure 6-14 Lower Chassis

6.1.5 Humidifier

1. Flat washer, M3 x 3.2, ID .5.....	6600-0712-402
2. Split ring lock washer, M3 x 3.1, ID .8.....	6600-0713-402
3. Screw, M3 x 16 Cheese head Phillips.....	6600-1255-404
4. Reservoir switch (included in item 21)	
5. Button, reservoir switch	6600-1298-500
6. Top humidifier gasket.....	6600-1293-500
7. Heater mount.....	6600-1291-500
8. Screw, M3 x 8 Cheese head Phillips, Teflon coated.....	6600-1255-401
9. Ramp block	6600-1777-500
10. Humidifier gasket bottom	6600-1294-500
11. Protective insert*.....	6600-1714-500
12. Reservoir seal.....	6600-1495-500
13. Insulating cylinder.....	6600-1182-500
14. Bottom bracket	6600-1181-500
15. Steam outlet	6600-1296-500
16. Silicone tube	6600-1780-500
17. Heater sheath	6600-1292-500
18. Nut, hex 6 -32	0144-3324-113
19. Split ring lock washer, #6.....	6600-0345-400
20. Safety thermostat assembly.....	6600-0225-850
21. Add water thermostat assembly (includes item 4).....	6600-0803-700
22. Humidifier heater *.....	6600-0224-850
23. Spacer, .125 ID.....	6600-1779-500
24. Humidifier top bracket.....	6600-1295-500
25. Star washer, M3 x 3.2 ID.....	6600-0713-442
26. Screw, M3 x 12 Cheese head Phillips.....	6600-1255-403
27. Humidifier reservoir.....	6600-0216-850
Reservoir bottom.....	6600-1493-500
Reservoir lid.....	6600-1492-500
28. Screw, M3 x 10 skt. hd.....	6600-0707-403
29. Screw, M3 x 10 Cheese hd. Phillips Teflon coated.....	6600-1255-402

Parts not shown

Humidifier assembly

(includes all parts above except reservoir).....6600-0245-850

* Always replace item 11 when replacing item 22.

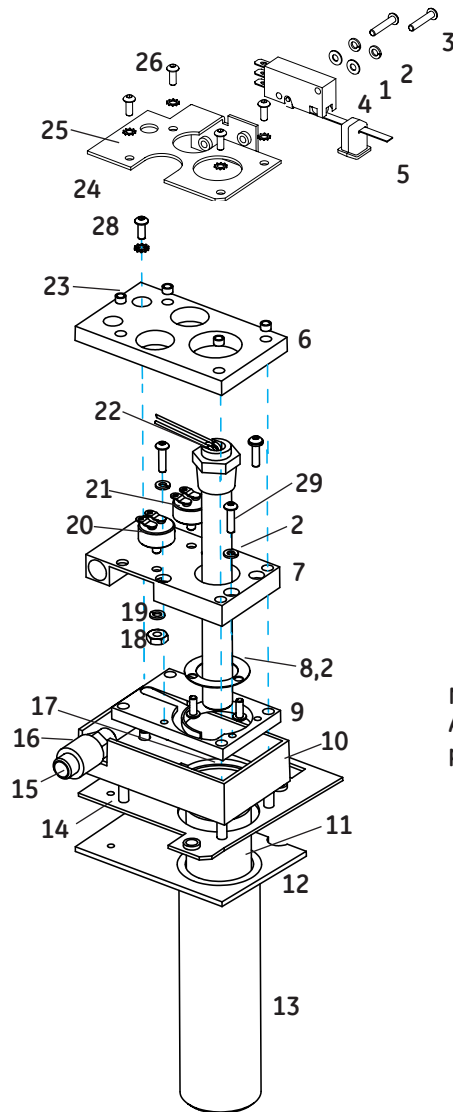

NOTE: Due to design changes, refer to "5.12 Humidifier Assembly Repairs" in Repair Procedures before ordering parts.

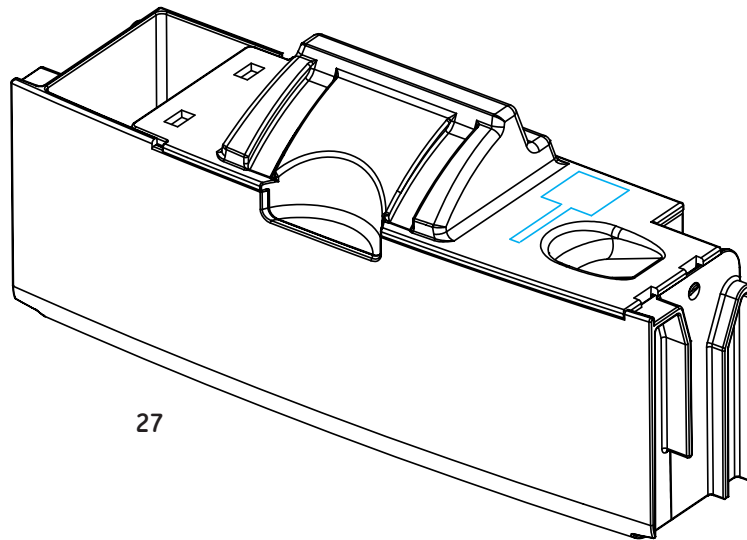
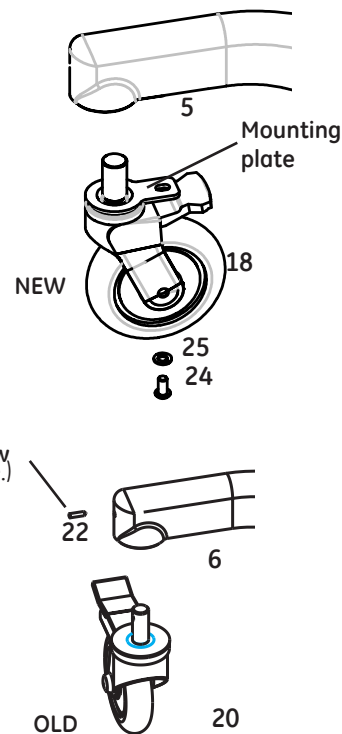

Figure 6-15 Humidifier Assembly

6.1.6 Elevating Base

1. Main bracket.....6600-1183-500
 2. Flat washer.....6600-0712-406
 3. Nut, M8.....6600-0714-405
 4. Inner shroud6600-1489-500
 5. Leg (new)6600-1599-500
 6. Leg (old).....6600-1323-500
 7. Bed up/down pedal (gray).....M1108745
Bed up/down pedals, set of two (gray).....M1108748
Bed up/down pedal assembly (teal) obsolete, use gray (M1108795)
 9. Nut, M4.....6600-0714-402
 10. Grommet, rubber0211-1526-300
 11. Screw, M4 x 12 shoulder6600-1205-400
 12. Speaker6600-1168-600
 13. Hood lift pedal (gray).....M1108743
(Includes one pedal and labels for both left and right pedals. Can be used on left or right side.)
Hood/base lift pedals, set of four (gray).....M1108795
(Includes two gray pedals for base and two gray pedals for the canopy.)
Hood lift pedal assy., all (teal) obsolete, use gray (M1108795)
 16. Lock washer.....6600-0713-408
 17. Screw, M12 button head6600-0706-448
 18. Caster, all (new).....6600-0890-400
 19. Caster, front (old)6600-1039-401
 20. Caster with shield, rear (old).....6600-1039-402
 21. Caster cap.....6600-1600-500
 22. Cone point set screw, M6 (old) @.....6600-0715-405
 23. Screw, M4 button head.....6600-0706-409
 24. Screw, M8 x 16 Btn. Hd. skt. (new)6600-0706-435
 25. Lock washer, M8 (new).....6600-0712-406
 26. Speaker bracket.....6600-1462-500
 27. Split ring lock washer M4.....6600-0713-403
 28. Screw, M4 x 25 Skt. Hd.....6600-0707-448
 29. Screw, M12 button head6600-0706-449
 30. Lock washer M126600-0713-408
 31. Screw, M66600-1117-402
 32. Lock washer.....6600-0713-405
 33. Star washer6600-0713-445
 34. Screw, M6 socket head6600-0706-427
 35. Leg wire cover, right (new).....6600-1545-700
 36. Leg wire cover, left (new).....6600-1546-700
 38. Mounting plate6600-1186-500
 39. Elevating column.....6600-0753-701
 40. Washer.....6600-0712-405
 41. Screw, M66600-0706-427
 42. External star washer.....6600-0713-443
 43. Flat washer.....6600-0712-403
 44. Clamp, 5/16.....0208-0335-300
 45. Outer shroud.....6600-1324-500
 46. Screw, M56600-0706-420
 47. Split ring lock washer6600-0713-404
 48. Flat washer.....6600-0712-409
 49. Wire routing clip.....6600-0866-600
- Parts not shown
Blue plastic connector clip for footswitch6600-1163-600



NOTE: Due to design changes, refer to "5.11 Caster Replacement" in Repair Procedures before ordering parts.

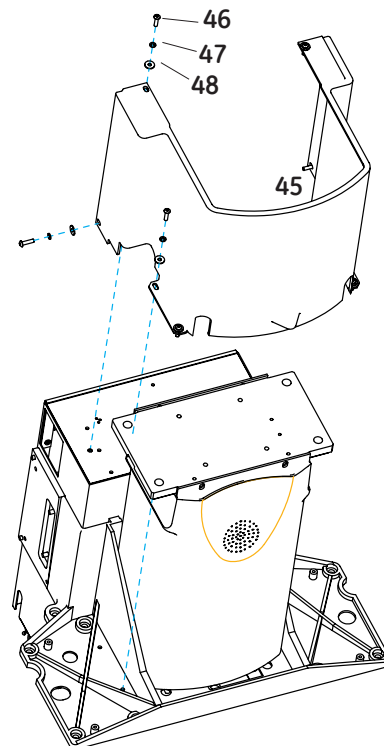

@Apply Loctite #242

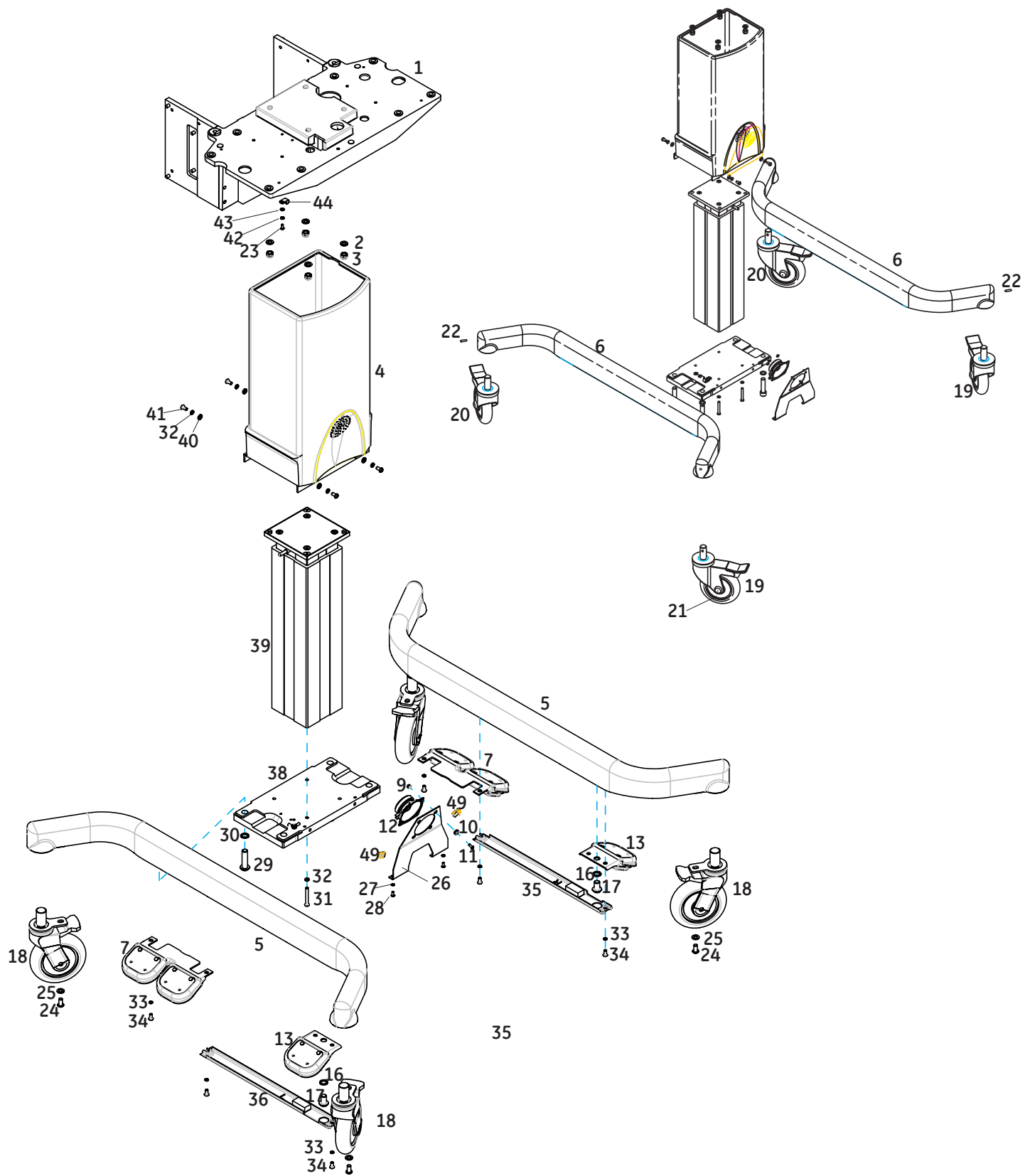

Figure 6-16 Base and Elevating Column

6.1.7 Uprights and Lift Rail Components

1.	Lift rail	6600-1332-500
2.	Lift motor isolator	6600-1099-400
3.	Lift motor bracket	6600-1767-500
4.	Flat washer, M4	6600-0712-403
5.	Split ring lock washer M4	6600-0713-403
6.	Screw, M4 x 6 Button Head	6600-0707-407
7.	Belt channel	6600-1312-500
8.	Right (east) upright@	6600-0288-850
9.	Pinch guard	6600-1383-500
	Circular loop fastener (order when ordering pinch guard)	6600-1177-400
	Spacer	6600-1751-500
10.	Roll pin	6600-1093-400
11.	Screw, M5 x 2 socket head cap	6600-1152-400
12.	Side roller pin**	6600-1098-400
13.	Screw, M4 x 10 socket head cap	6600-0707-409
14.	Split ring lock washer, M4	6600-0713-404
15.	Side roller**	6600-1450-500
16.	Side roller bracket**	6600-1451-500
17.	Roller	6600-1770-500
18.	Retaining ring	6600-1182-400
19.	Pin guide	6600-1496-500
20.	Bracket	6600-1483-500
21.	Split ring lock washer, M5	6600-0713-404
22.	Screw, M5 x 10 Button Head	6600-0706-417
23.	Rod	6600-1390-500
24.	Nut M5	6600-0711-408
25.	Flat washer M5	6600-0712-404
26.	Brass spacer	6600-1186-400
27.	Grommet	6600-1187-400
28.	Split ring lock washer	6600-0713-404
29.	Bracket	6600-1389-500
30.	Tube	6600-1391-500
31.	Nylok nut, M5	6600-0714-403
32.	Spring*	6600-1101-400
33.	Cap	6600-1410-500
34.	Spring tube assembly (items 23-33)	6600-0854-700
35.	Hole plug	6600-1150-400
36.	Cable clamp	6600-1064-400
37.	Screw, M4 x 2	6600-0707-412
38.	Screw, M4 x 8	6600-0706-408
39.	Nut, M4	6600-0711-407
40.	Roll pin	6600-1123-400
41.	Gearbox coupler	6600-1176-400
42.	Motor and gear box kit	6600-0217-850
43.	Set-screw	6600-0715-408
44.	Screw	6600-0707-431
	Parts Not Shown (hardware to mount rail to chassis):	
	Screw M6 X 16 button head	6600-0706-428
	Star washer M6 X 6.41 ID	6600-0713-434

*Apply Lubriplate to spring to dampen noise.

@ Order labels 6600-2347-101 and 6600-2341-1XX when replacing upright. Refer to section "6.3 Labels".

** The side roller pin, side roller bracket, and side roller should be ordered together and assembled with pliers to press in the pin.

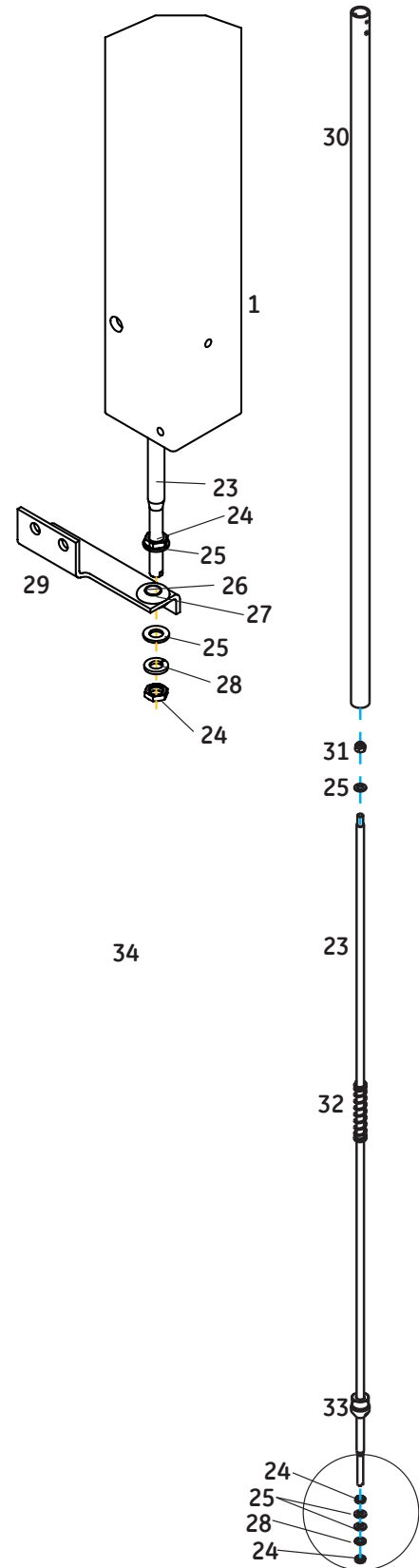

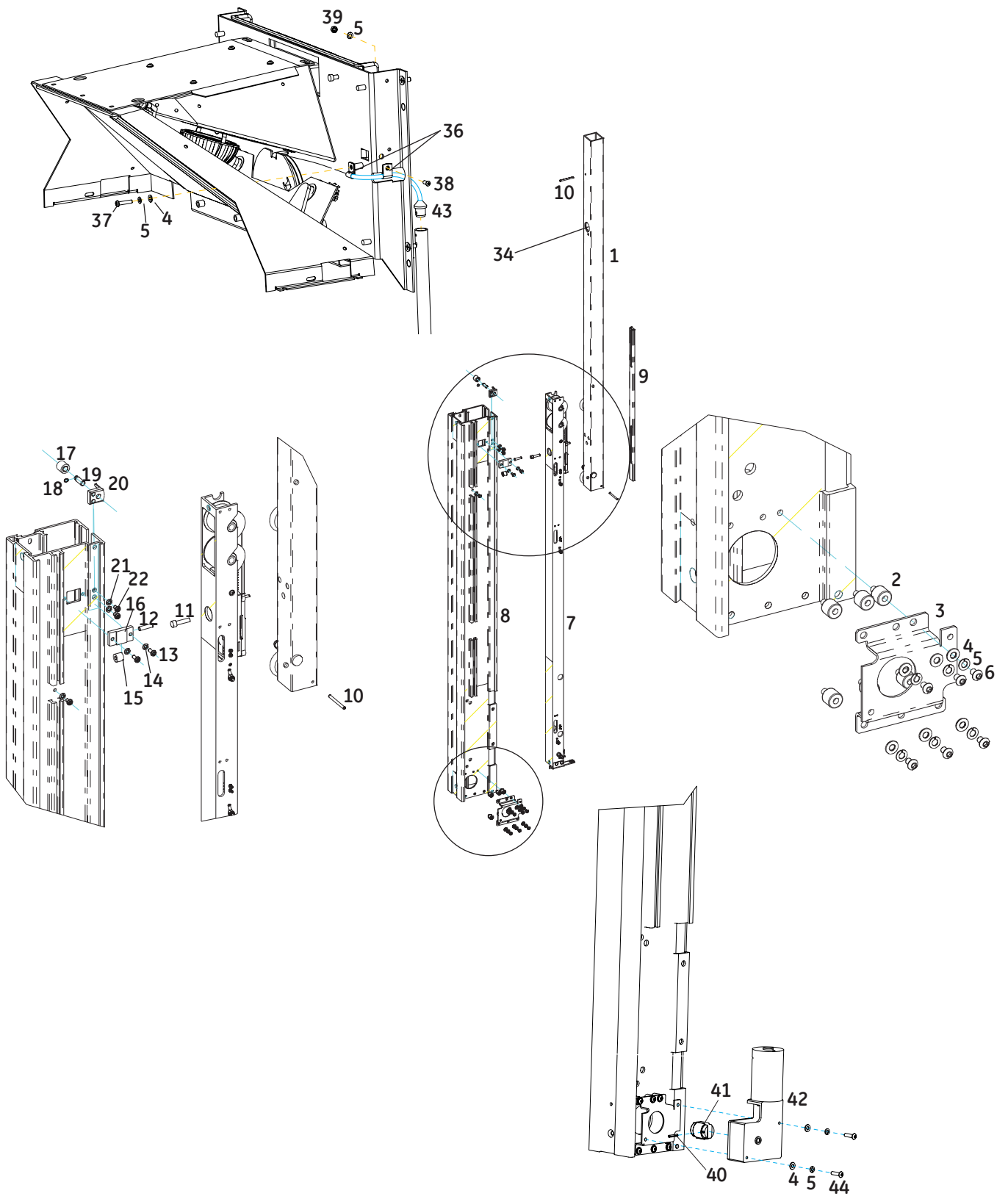

Figure 6-17 Right (East) Upright Parts, Motor Side (Complete East Rail Assembly: 6600-0290-850)

1. Upper buoyancy spring*	6600-1464-500
2. Spool.....	6600-1317-500
3. Plastic washer.....	6600-1708-500
4. Lock nut, M3.....	6600-0714-401
5. Lower buoyancy spring*	6600-1465-500
6. Screw, M3 x 10 Button head.....	6600-0706-401
7. Lock washer, M3.....	6600-0713-402
8. Lift belt (Current revision is white.)**	6600-1372-500
9. Block adjuster, top.....	6600-1358-500
10. Belt block bottom.....	6600-1359-500
11. Spring switch actuator.....	6600-1362-500
12. Screw, M3 x 20 button head.....	6600-0706-404
13. Screw, M3 x 10 button head.....	6600-0706-401
14. Split ring lock washer, M3.....	6600-0713-402
15. Flat washer, M3.....	6600-0712-402
16. Belt tensioner spring.....	6600-1071-400
17. Belt block cover.....	6600-1360-500
18. Screw, M3 x 10 flat head socket.....	6600-1151-400
19. Belt adjuster, bottom.....	6600-1357-500
20. Belt guide block.....	6600-1815-500
21. Spacer.....	6600-1491-500
22. Belt switch assembly guide.....	6600-1769-500

Parts not shown:

Micro-switch (part of switch harness).....	Refer to wiring diag.
Switch hardware	
Screw, M2 x 16 fillister head.....	6600-0710-408
Split ring lock washer, M2.....	6600-0713-401
NutM2.....	6600-0711-401

*Replace all the buoyancy springs at one time.

**When ordering the lift belt, also order a belt block cover, a bottom belt adjuster, and two M3 x 10 flat head socket screws.

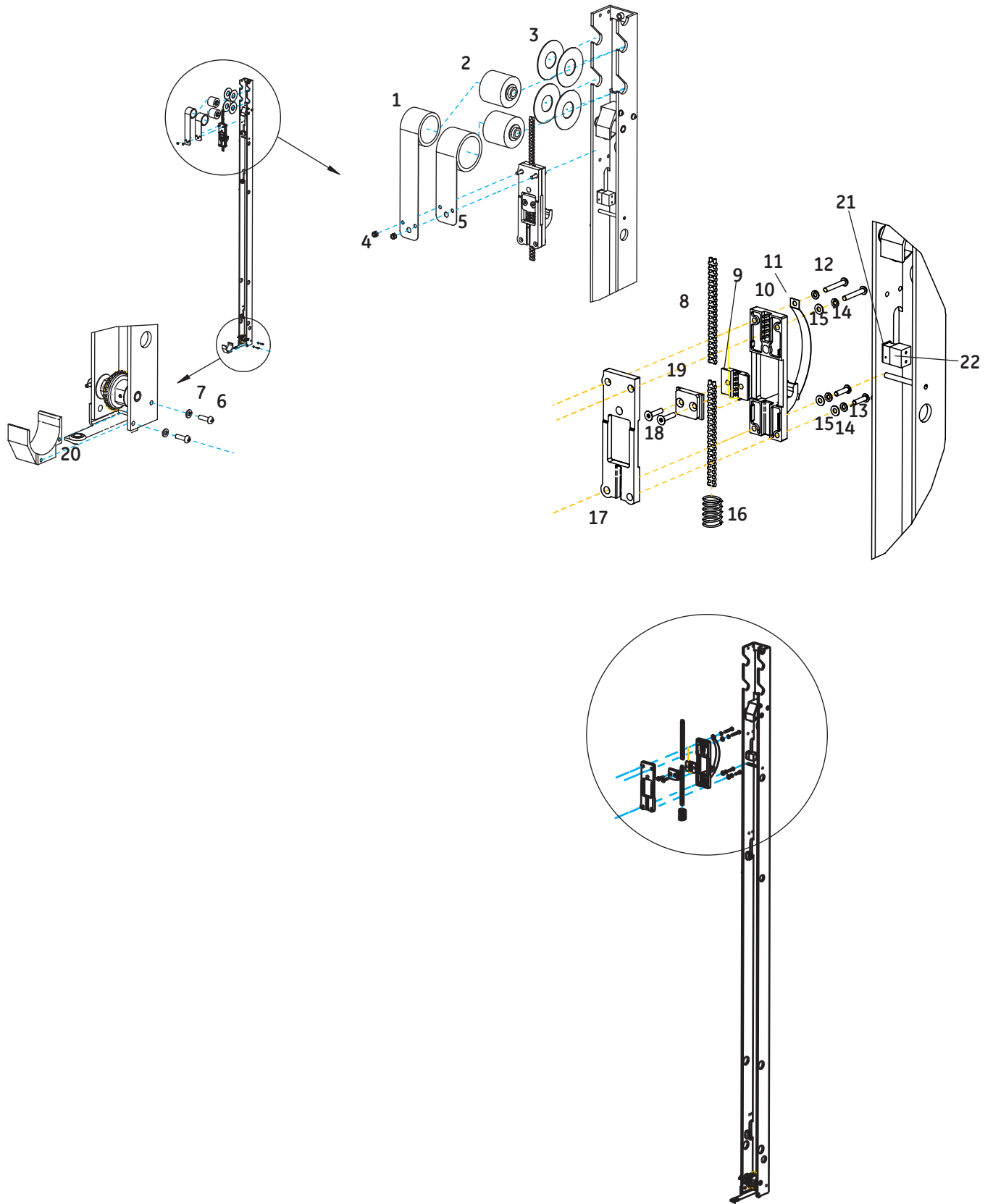

Figure 6-18 Belt Channel - 1 (Lift Motor Side)

1. Grooved pin.....	6600-1185-400
2. Bottom sprocket axle	6600-1375-500
3. Washer.....	6600-1184-400
4. Slip clutch assembly.....	6600-0868-700
5. Top sprocket axle	6600-1374-500
6. Spacer.....	6600-1376-500
7. Sprocket.....	6600-1373-500
8. Belt guide block*	
9. Spacer.....	6600-1377-500
10. Split ring lock washer, M3	6600-0713-402
11. Screw, M3 x 16 button head.....	6600-0706-403
12. Lock washer, M3*	6600-0713-402
13. Screw, M3 x 10 button head*	6600-0706-401
14. Bearing.....	6600-1090-400
15. Brass spacer	6600-1186-400
16. Rubber grommet	6600-1187-400
17. Bracket.....	6600-1389-500
18. Slip clutch roll pin	6600-1198-400

*Top belt guide block no longer used; it can be removed if desired.

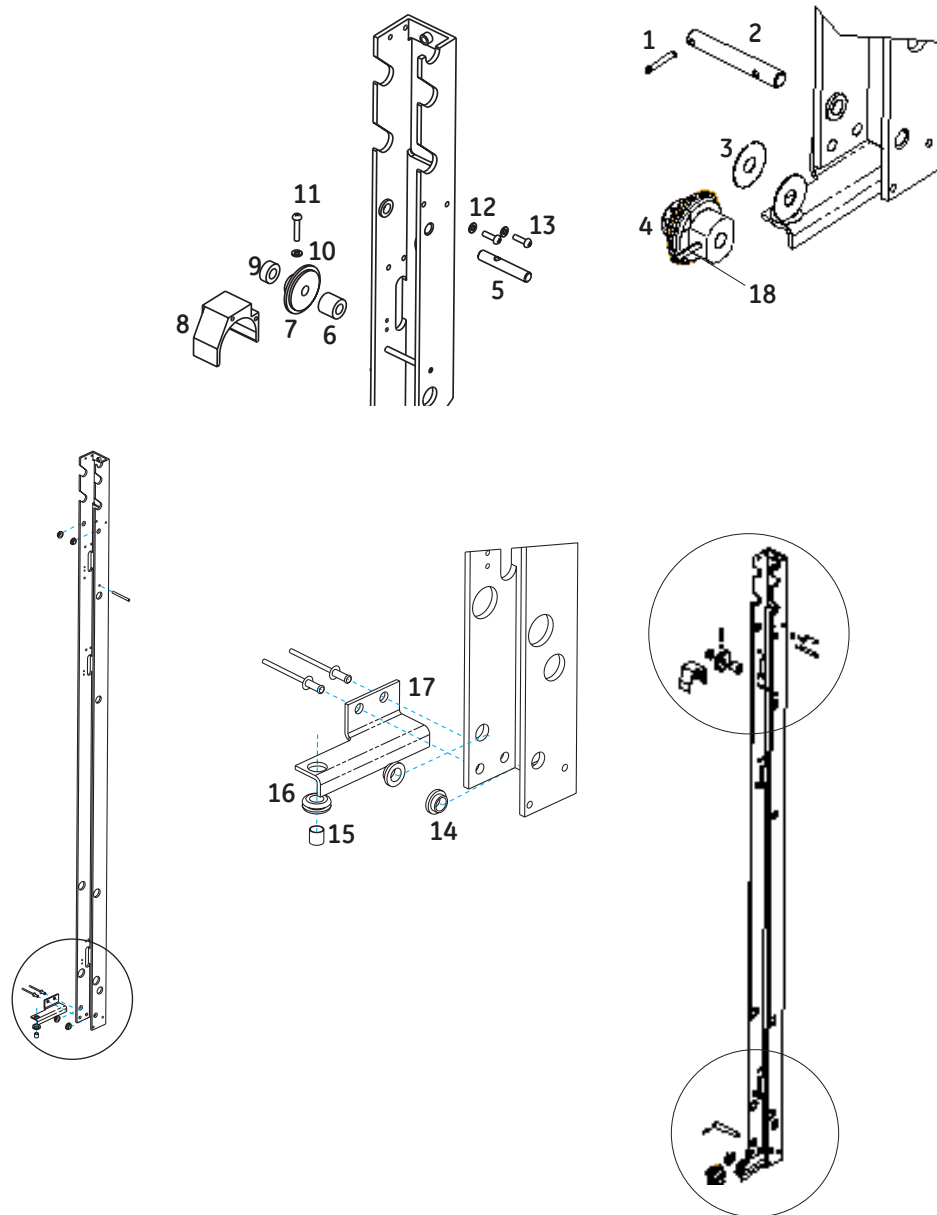

Figure 6-19 Belt Channel - 2 (Lift Motor Side)

1. Washer.....	6600-1088-400
2. Outer roller.....	6600-1318-500
3. Short bearing.....	6600-1086-400
4. Lock washer, internal tooth.....	6600-0713-434
5. Screw, M6 x 16 button head.....	6600-0706-428
6. Inner roller.....	6600-1750-500
7. Stepped bushing.....	6600-1749-500
8. Screw, M6 x 20 button head.....	6600-0706-429
9. Screw, M5 x 20 socket head.....	6600-0707-480
10. Standoff.....	6600-1740-500
11. Rail brake pad.....	6600-1161-400
12. Roller bracket post assembly.....	6600-0809-700
13. Roller tensioning spring (right/east).....	6600-1367-500
Roller tensioning spring (left/west).....	6600-1162-400

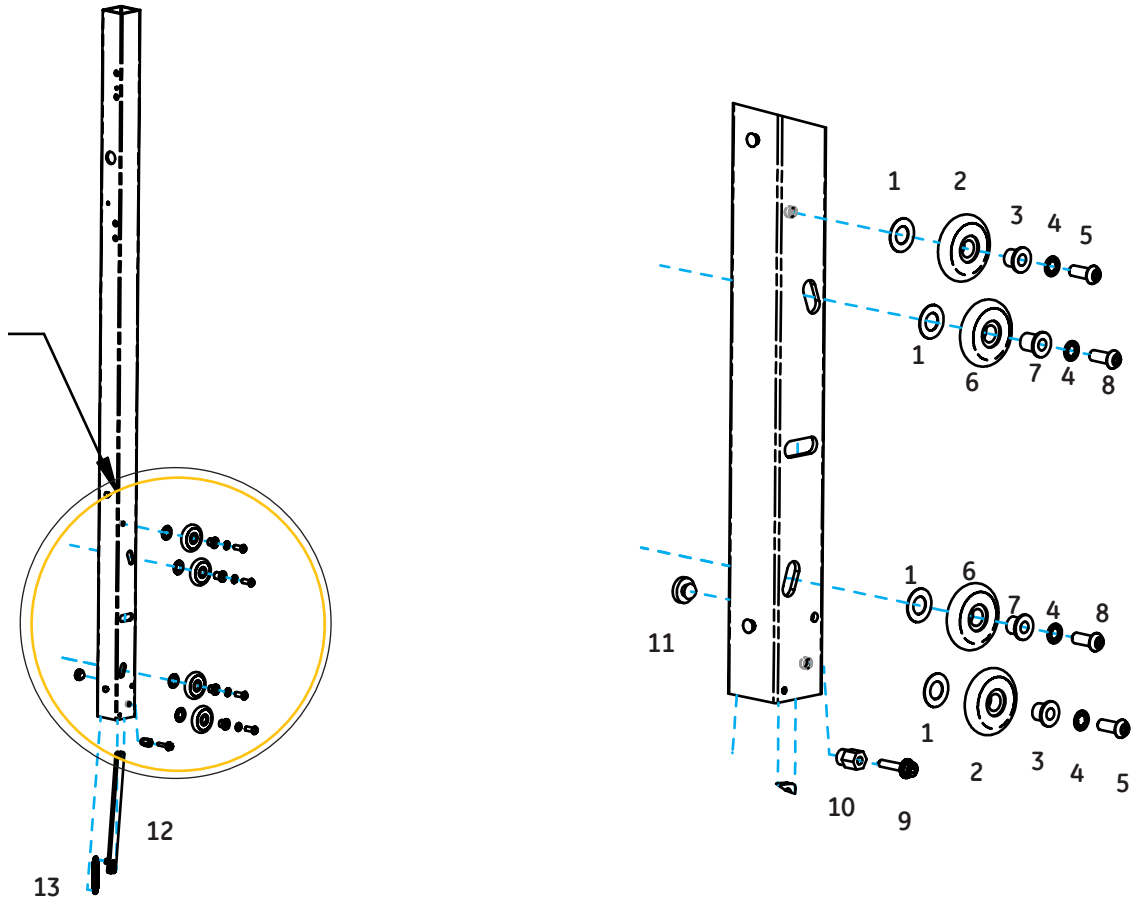

Figure 6-20 Lift Rail (Both Sides)

1. End cap, top inside left (west)	6600-1339-500
2. Roll pin	6600-1095-400
3. Spring	6600-1089-400
4. End cap, top outside left (west)	6600-1340-500
Circular loop fastener (order when ordering end cap).....	6600-1177-400
5. Screw, M4	6600-0708-409
6. End cap, top inside right (East)	6600-1468-500
7. End cap, top outside right (East).....	6600-1337-500
Circular loop fastener (order when ordering end cap).....	6600-1177-400
8. Decorative strip (teal).....	6600-1456-501
9. End cap, bottom right (East)	6600-1463-500
10. End cap, bottom left (west)	6600-1341-500
11. Cord wrap	6600-1482-500
Dog point set screw	6600-1124-400
12. Routing clips (6)	6600-0055-851
13. Countersunk washer (2).....	M1089713

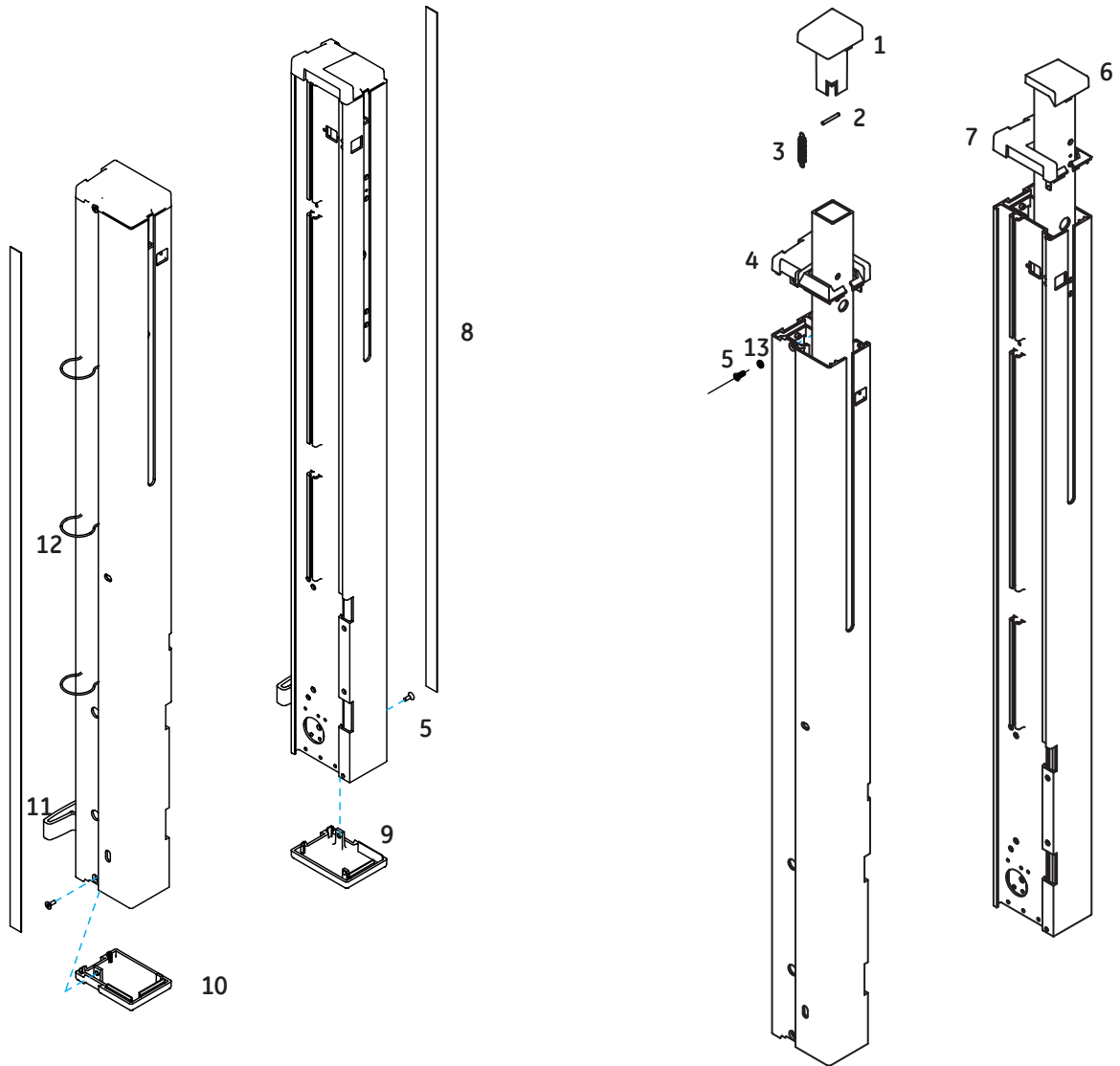
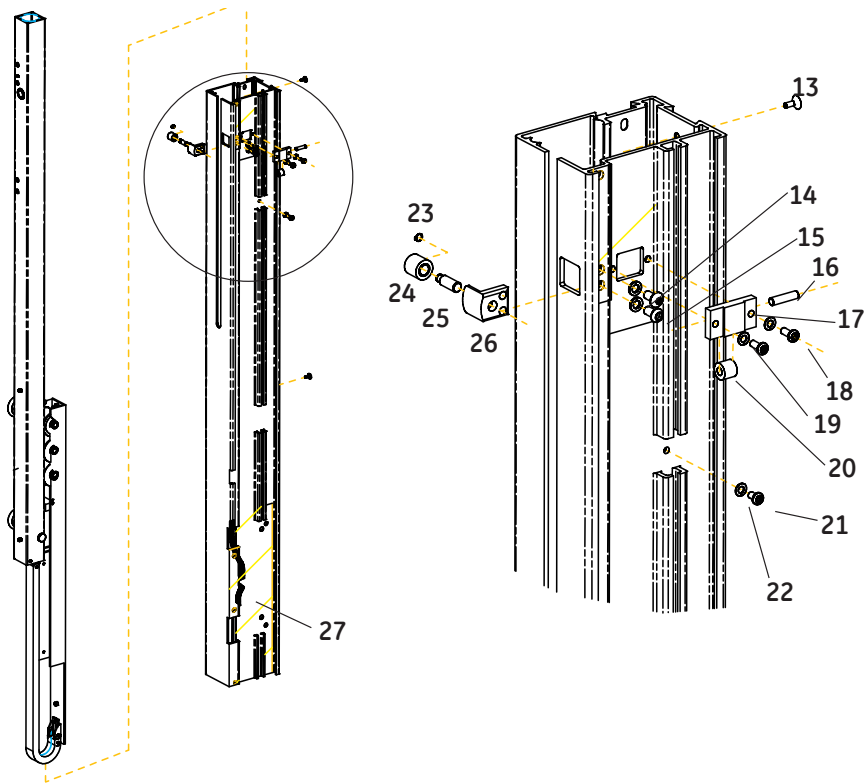

Figure 6-21 Rail End Caps



1. Spring, upper*	6600-1464-500
2. Spring, lower*	6600-1465-500
3. Spring, left (west) only*	6600-1725-500
4. Screw, M5 x 20 socket head	6600-1152-400
5. Spacer	6600-1103-400
6. Roll pin	6600-1093-400
7. Stop block, left (west) only	6600-1712-500
8. Heater wire harness/cable carrier assembly***	6600-0710-700
9. Spring bracket, left (west) only	6600-1350-500
10. Spring spool	6600-1317-500
11. Plastic washer	6600-1708-500
12. Lift rail	6600-1333-500
13. Screw, M4 x 12 flat head socket	6600-0708-409
14. Split ring lock washer, M5	6600-0713-404
15. Screw, M5 x 10 button head socket	6600-0706-409
16. Side roller pin**	6600-1098-400
17. Side roller bracket**	6600-1451-500
18. Screw, M4 x 10 socket head	6600-0707-409
19. Split ring lock washer M4	6600-0713-403
20. Side roller**	6600-1450-500
21. Screw, M4 x 6 socket head	6600-0707-407
22. Star washer M4 Int.	6600-0713-432
23. Retaining ring	6600-1182-400
24. Front roller	6600-1770-500
25. Front roller pin	6600-1496-500
26. Front roller bracket	6600-1483-500
27. Left (west) upright	6600-0288-851

*Replace all the buoyancy springs at one time.

** The side roller pin, side roller bracket, and side roller should be ordered together. Use pliers to press the pin into the side roller bracket.

*** When ordering this assembly, also order 6600-1097-603, unless you have a pin extractor. For details, refer to section 5.5.5.

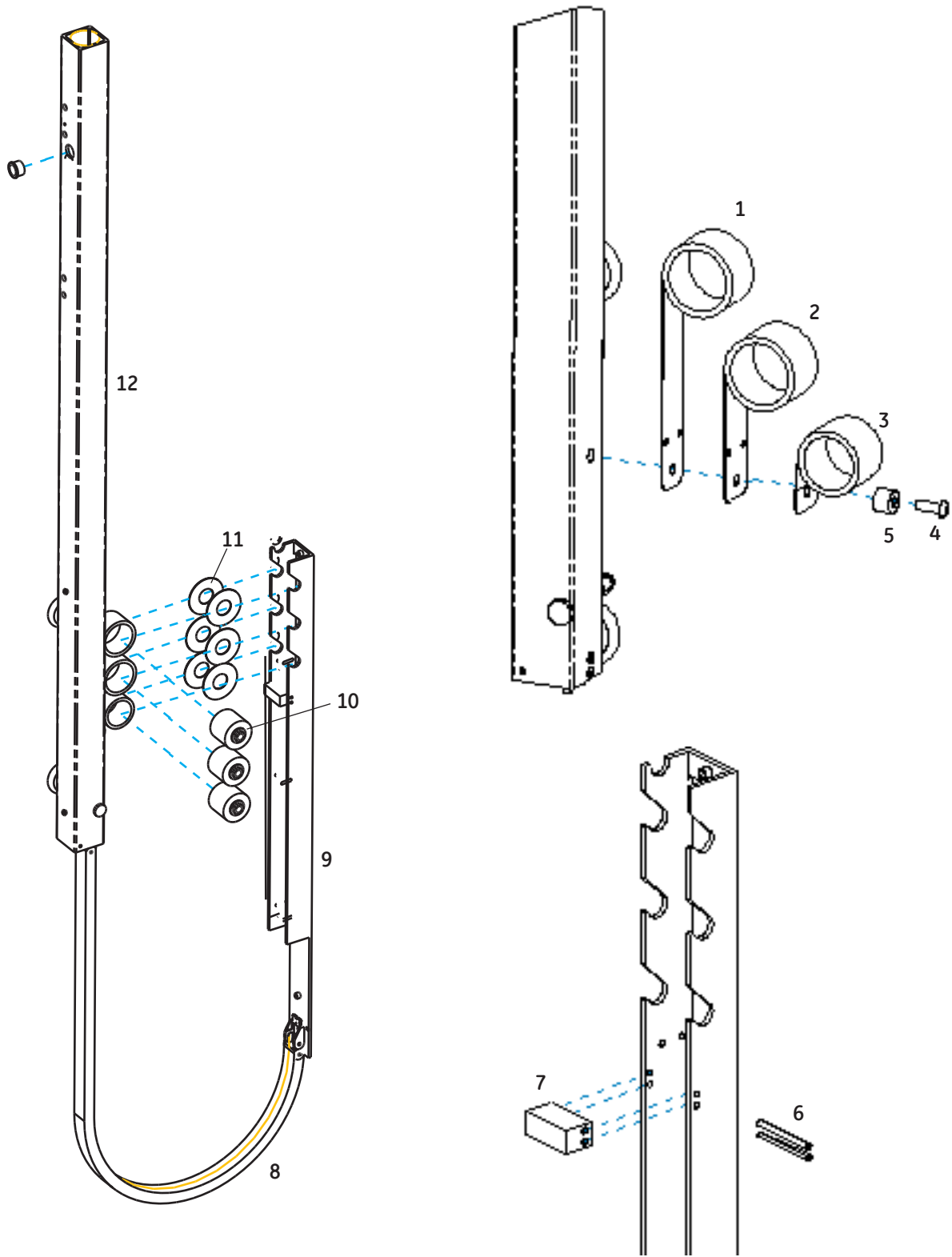

Figure 6-22 Left (West) Upright (Complete West Rail Assembly: 6600-0290-851)

6.1.8 Compartment Air Probe

1. Compartment air probe@	6600-1512-700
Probe wire harness@	6600-1513-700
2. O-ring	6600-0540-400
3. Humidity sensor assembly*	6600-0784-700
Plug (no humidity sensor installed)	6600-1476-500
4. Retainer	6600-1475-500
5. Break plate	6600-1473-500
6. Screw, M3 x 6 button hd	6600-0706-406
7. Back plate	6600-1474-500
8. Flat washer, M3	6600-0712-402
9. Split ring lock washer	6600-0713-402
10. Screw, M3 x 20 button hd	6600-0706-404
11. Screw, M4 button hd	6600-0706-411
12. Cable clamp	6600-0144-400
13. Lock nut, M4	6600-0714-402
Parts not shown	
Humidifier Calibration Kit*	6600-0048-850

* Unit must be recalibrated using Humidifier Calibration Kit whenever sensor is replaced.

@ For earlier units with a compartment air probe cable that disconnected at the probe panel, order service kit 6600-0241-850.

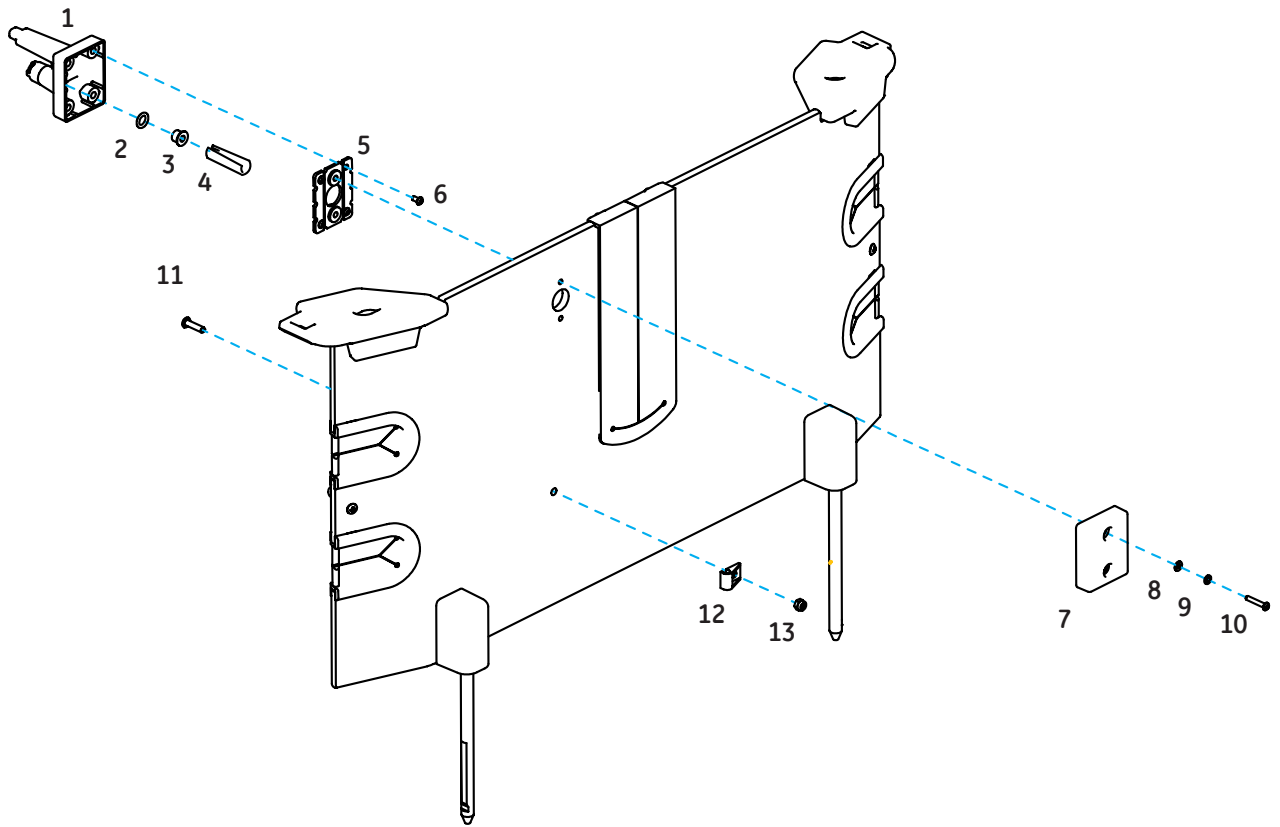

Figure 6-23 Compartment Air Probe

6.1.9 Servo Control Oxygen

1.	Screw, M4 Skt Hd	6600-0868-402
2.	Sensor housing cover	6600-1876-500
3.	Oxygen sensor kit (2 pcs.)@	6600-0120-850
4.	Sensor gasket.....	6600-1887-500
5.	Screw, M3x10L Skt Hd	6600-0707-403
6.	Split ring washer, M3.....	6600-0713-402
7.	Flat washer, M3.....	6600-0712-402
8.	Screw, M2.9x16L, self tap	6600-0709-411
9.	Calibration fan with harness*.....	6600-1510-700
10.	Calibration valve assembly (includes gasket)	6600-1539-700
	Calibration valve mounting screws (2)- M4x12L Fl Hd Skt	6600-0708-409
11.	Male/female shoulder screw	6600-0862-400
12.	Push fitting, 90 degree elbow	6600-0865-400
13.	Chassis Vent.....	6600-2017-500
14.	Vent cover.....	6600-2018-500
15.	Vent screen	6600-2020-500
	Vent screens (5)	6600-0271-850
16.	Washer (thin).....	6600-1236-400
17.	Panel hex nut.....	6600-1275-400
18.	M12 Split ring washer.....	6600-0713-408
19.	Sensor housing.....	6600-1875-500
20.	Push fitting, straight.....	6600-0877-400
21.	Screw, M4x6L Button Hd	6600-0706-407
22.	Sensor housing board (also includes the board inside the sensor housing cover).....	6600-1511-700
23.	Sensor plug assembly	6600-0604-700
	Sensor housing assembly (includes all parts above except item 3).....	6600-1506-700
24.	Star washer, int. M4.....	6600-0713-432

Tubing (order by inch)

6mm black.....	6600-0129-300
from sensors to manifold, 3.9"	
from chassis vent to manifold, 3.9"	
6mm white.....	6600-0866-400
from cal fan to manifold, 4.7"	
from manifold to heatsink vent, 4.7"	

*Install fan so flow arrow on side points up into chassis.

@ The date on the sensor is a discard date; the sensor should be removed from service on that date.

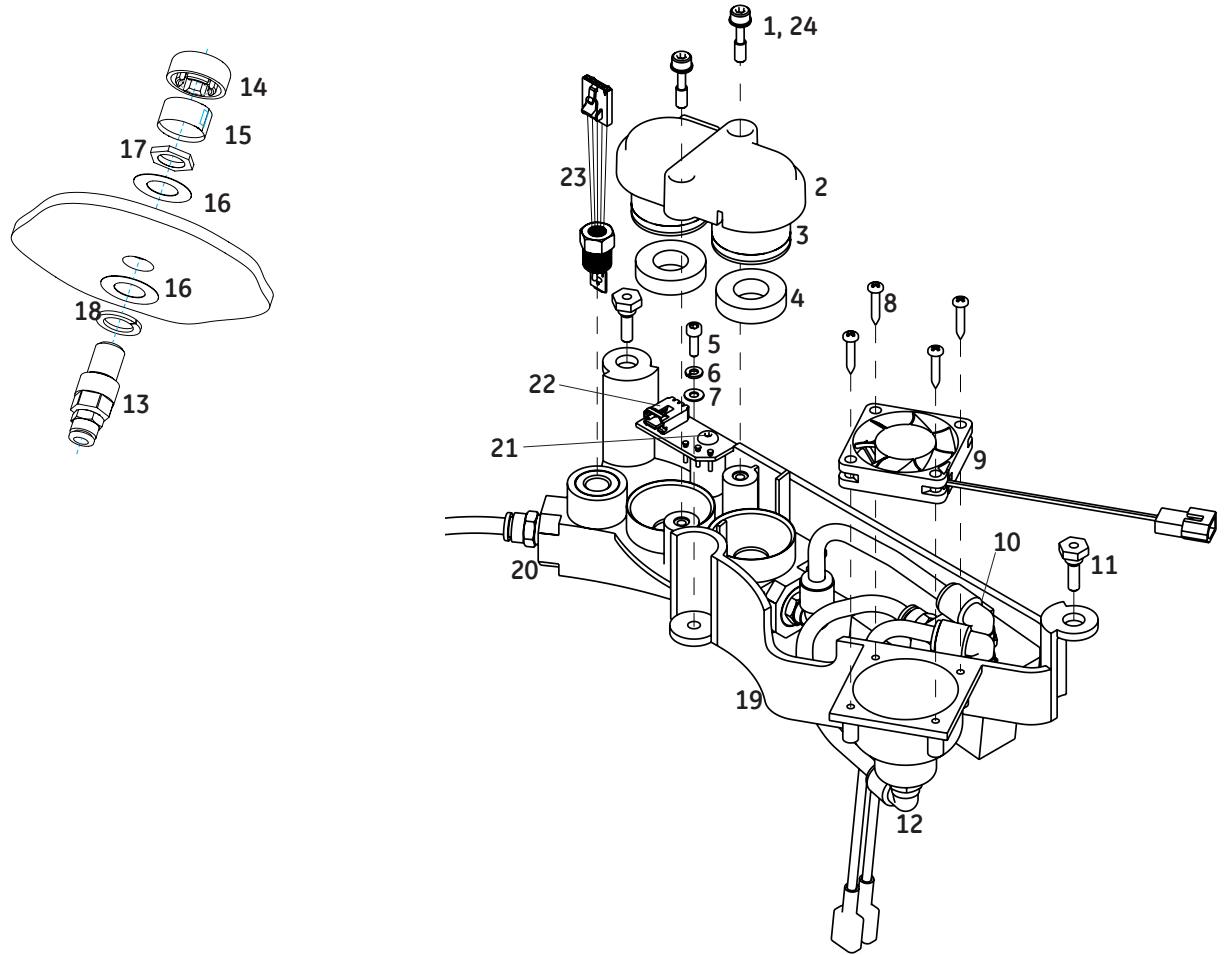

Figure 6-24 Servo Control Oxygen Sensor Housing Assembly (Servo O2 Upgrade Kit 6600-0678-800)

Servo Control Oxygen Service Kits:

OmniBed DISS	6600-0678-800
OmniBed NIST	6600-0678-801
OmniBed DIN	6600-0678-802
OmniBed Air Liquide.....	6600-0678-803

1. Screw, M4x12L Skt Hd.....	6600-0707-410
2. Split ring washer, M4.....	6600-0713-403
3. Valve housing top cover.....	6600-1838-500
4. Valve housing wire harness.....	6600-1069-700
5. Adapter 1/8NPTFx1/8NPTM.....	6700-0616-800
6. Elbow fitting 10 OD x1/8NPT.....	6600-0873-400
7. Screw, M4 Skt Hd.....	6600-1051-400
8. Flat washer, M5.....	6600-0712-409
9. Damper manifold mount.....	6600-1248-400
10. Valve housing.....	6600-1836-500
11. Valve housing bottom cover.....	6600-1837-500
12. Jam nut, M14.....	6600-0711-450
13. Label Max kPa.....	6600-2448-101
Label Max PSI.....	6600-2448-102
14. Lock washer, M14 Int tooth.....	6600-0713-438
15. Push-in fitting, 90° Elbow.....	6600-0865-400
16. Supply valve.....	6600-0602-700
17. Manifold.....	6600-1839-500
Plug.....	0413-3510-335
Gasket.....	6600-1950-500
18. Regulator assembly.....	6600-0254-850
In-line screen fitting.....	6600-1249-400
19. O2 adapter, Air Liquide.....	6600-0725-400
20. O2 adapter, DIN.....	6700-0050-700
21. O2 adapter, NIST.....	6600-0100-400
22. O2 adapter, DISS.....	6700-0522-800
23. Washer, M4.....	6600-0712-403
Parts not shown:	
Oxygen inlet label (green).....	6600-2611-101
Oxygen inlet label (white).....	6600-2611-102
Valve housing assembly (includes all parts above except items 11, 13 and mounting hardware).....	6600-1507-700
6mm Tubing (order by inch).....	6600-0866-400
From regulator to manifold, 3.9" Tubing/sleeve assembly.....	6600-0262-850
10mm tube from valve housing to expansion chamber, 27"	

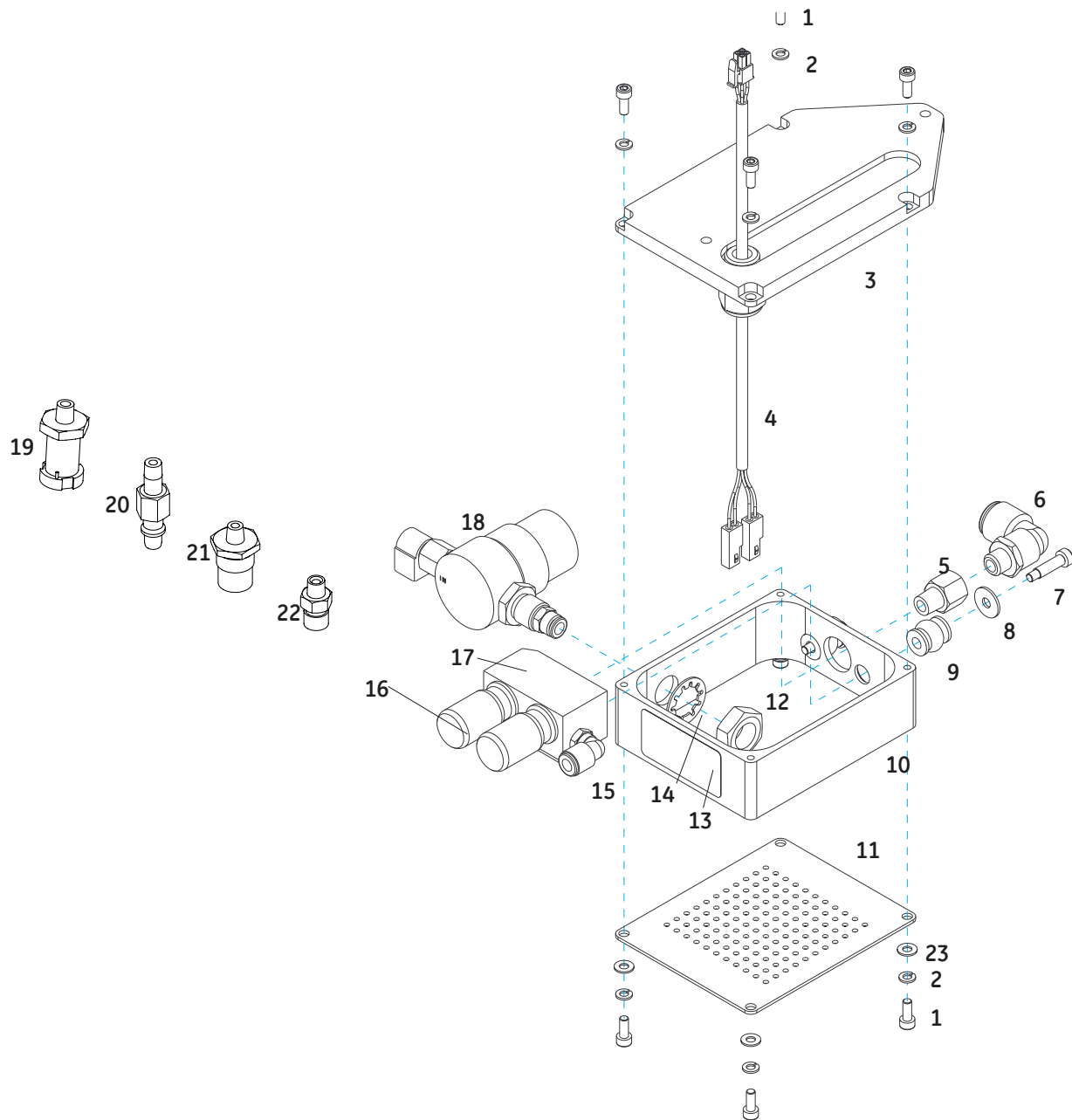

Figure 6-25 Servo Control Oxygen Valve Housing

1. Screw, M4 Skt Hd	6600-0706-409
2. Split ring washer, M4.....	6600-0713-403
3. Flat washer, M4.....	6600-0712-403
4. Expansion chamber cover	6600-1878-500
5. Cover gasket.....	6600-1883-500
6. Elbow fitting.....	6600-0873-400
7. Expansion chamber assembly (includes items 1-6).....	6600-0256-850
8. Vent.....	6600-1881-500
9. Washer (thick).....	6600-1219-400
Parts not shown	
P-clamp (under Pleur-evac holder)	0690-1240-331
Washer, M6 (under Pleur-evac holder)	6600-0712-405
Expansion chamber inlet gasket.....	6600-1884-500

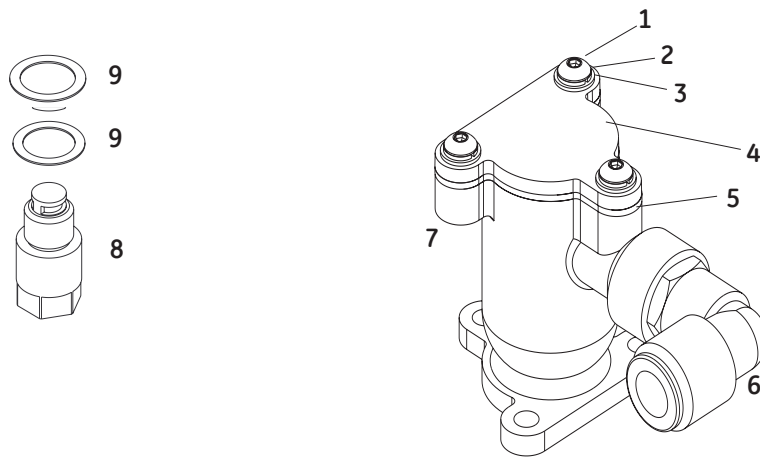

Figure 6-26 Expansion Chamber/Heatsink Vent

- | | |
|---------------------------------------|---------------|
| 1. Nylok nut, M4 | 6600-0714-402 |
| 2. Cooling fan assembly* | 6600-1523-700 |
| 3. Flat washer, M4..... | 6600-0712-403 |
| 4. Screw, M4x20L Button Hd | 6600-0706-412 |
| 5. Screw, captive 8mm long | 6600-0868-401 |
| 6. Screw, SEMS M4 x 6 Button Hd | 6600-0908-402 |

Parts not shown

Cable tie

6600-0384-400

*Install fan so flow arrow on side points down, away from chassis.

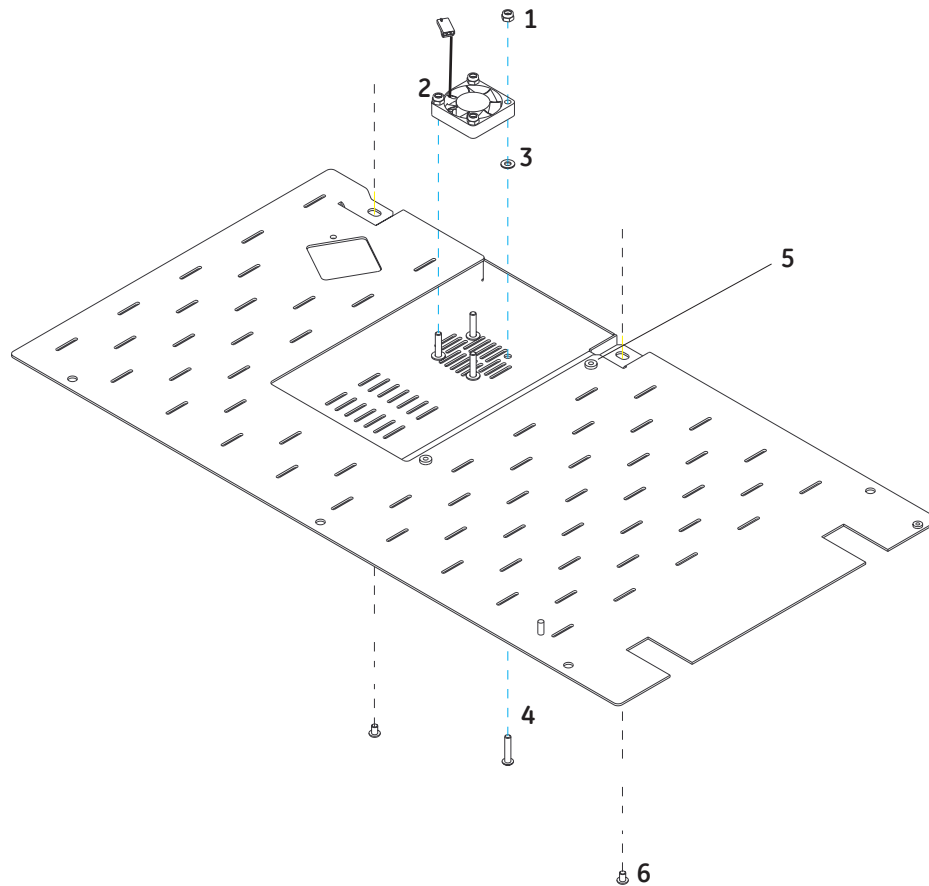

Figure 6-27 Servo Control Oxygen Cooling Fan

- 1. Servo Oxygen PCB6600-0233-850
- 2. Card guide, black.....6600-1064-400
- 3. Card guide, white.....6600-1183-400
- 4. Nut, M3.....6600-0711-403
- 5. Lock washer, int. tooth.....6600-0713-431

Parts not shown

- EPROM (U6).....6600-0255-850
- In-line fuse cable*6600-0618-700
- ESU label (located on probe panel)6600-2540-101

*Fuse is not replaceable; you must order cable to replace fuse.

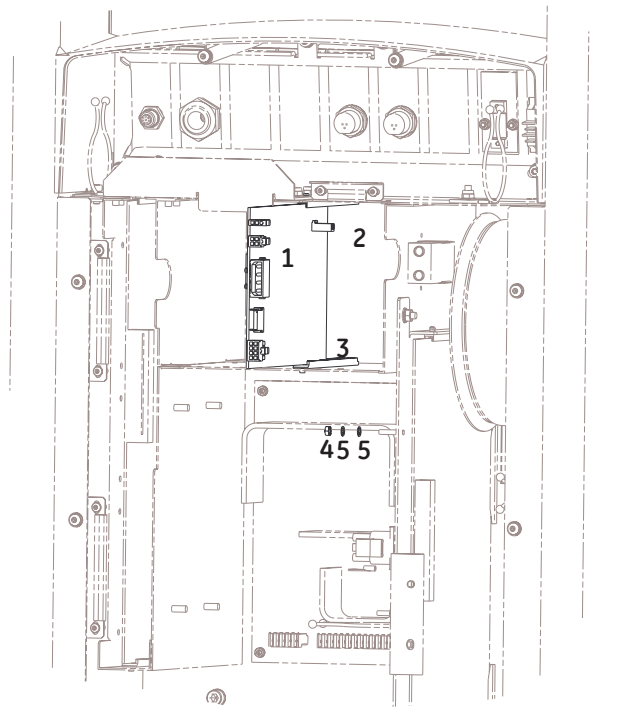

Figure 6-28 Servo Control Oxygen PC Board

1. Screw, M4 x 10 flt. hd.....	6600-0715-418
2. Split ring washer, M4.....	6600-0713-403
3. Spring Cover	6600-2025-500
4. Valve retaining tube	6600-2016-500
5. Spring kit	6600-0273-850
6. Two-way valve*.....	6600-1272-400
7. Manifold retaining pin.....	6600-2013-500
8. Screw, M4 x 25 btn. hd.....	6600-0706-413
9. Manifold endcap.....	6600-2012-500
10. Screw, M4 flt. hd.....	6600-0708-409
11. Elbow fitting 10 x 1/8 NPT	6600-0873-400
12. Tube 10 x 6.5 ID w sheath	6600-0274-850

*When replacing the valve or O-ring, lubricate its two O-rings with Vac Kote (6700-0092-200).

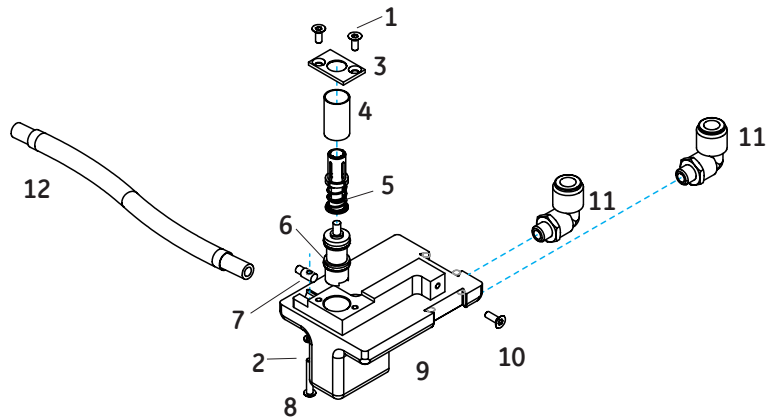

Figure 6-29 Manifold Endcap Safety Valve

6.1.10 Storage Drawer

1. Drawer slide.....6600-1717-500
2. Drawer mounting bracket*, front (south).....6600-1781-500
3. Screw, M4 x 12 Button HD.....6600-0706-410
4. Screw, M4 x 8 Button HD.....6600-0706-408
5. Split ring, M46600-0713-403
6. Flat washer, M4.....6600-0712-446
7. Storage drawer.....6600-1279-500
8. Screw, M5 x 12 Button HD Nylok.....6600-0715-410
9. Star washer, M5 internal tooth.....6600-0713-433
10. Drawer mounting bracket*, rear (north).....6600-1716-500
11. Tray6600-1718-500

* In order to remove the drawer, you must first disassemble the drawer from the drawer slides.

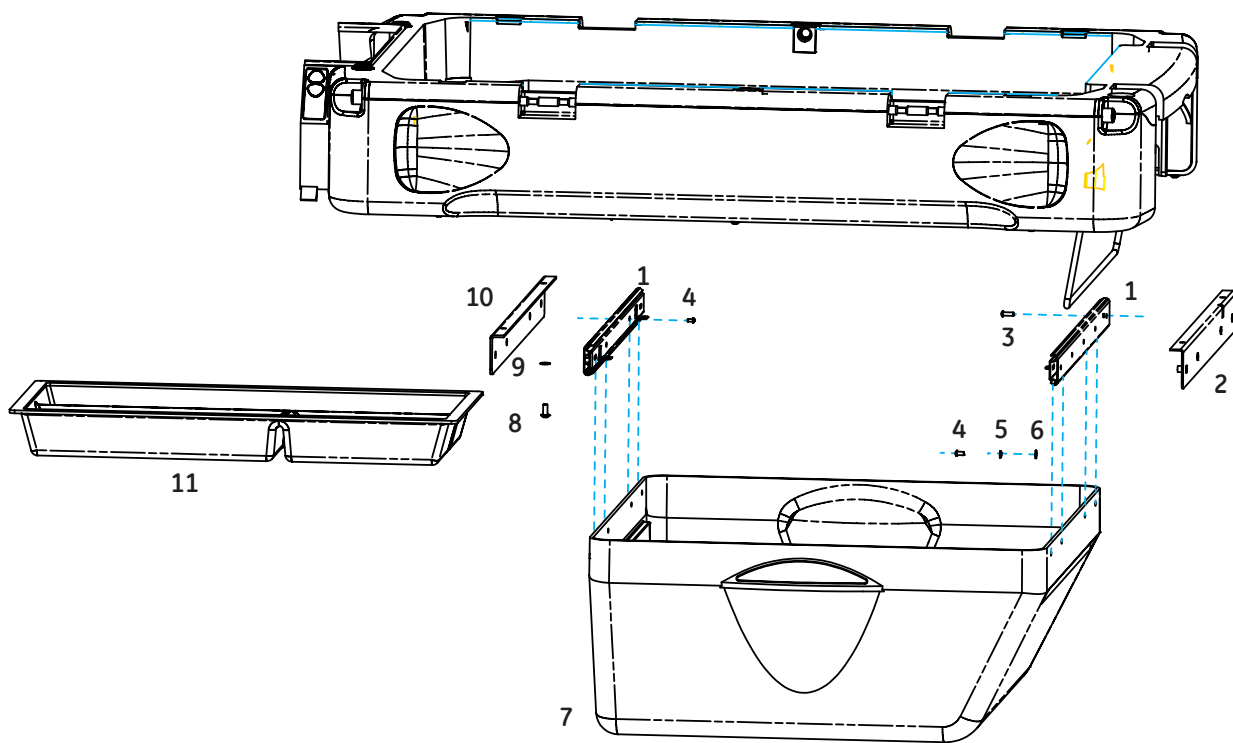

Figure 6-30 Storage Drawer

1. Weight limit label.....6600-1839-101
2. Washer.....0202-0095-300
3. Knob0217-5335-300
4. Shelf (order item 1 when replacing shelf).....6600-1733-500

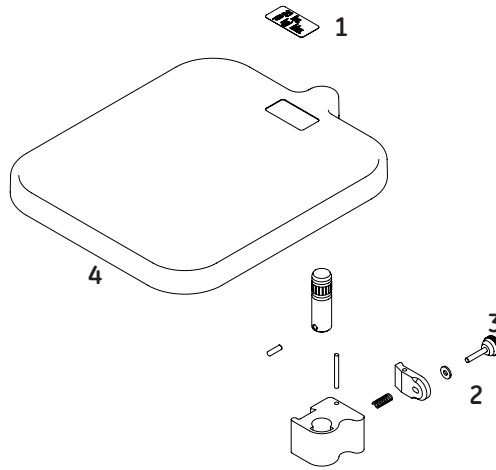

Figure 6-31 Instrument Shelf (6600-0865-700)

1. Shelf (order item 2 when replacing shelf).....6600-0481-501
2. Weight limit label.....6600-1941-101
3. Shelf support6600-0811-501
4. Mounting block assembly.....6600-0290-800
5. Washer.....0202-0095-300
6. Knob0217-5335-300
7. Screw, 1/4 - 20 x 5/8.....6600-0394-400

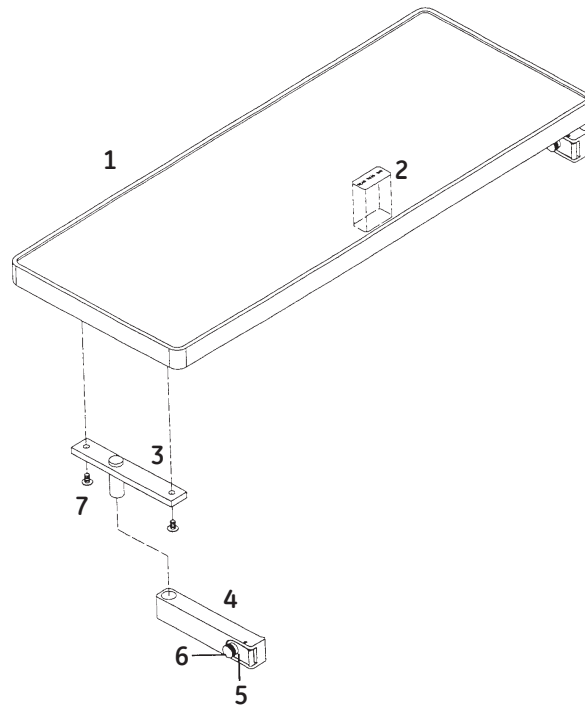

Figure 6-32 Monitor Shelf (6600-0824-800)

CYLINDER HOLDER ASSEMBLY.....	M1151570
CYLINDER HOLDER ASSEMBLY, XL.....	M1151571

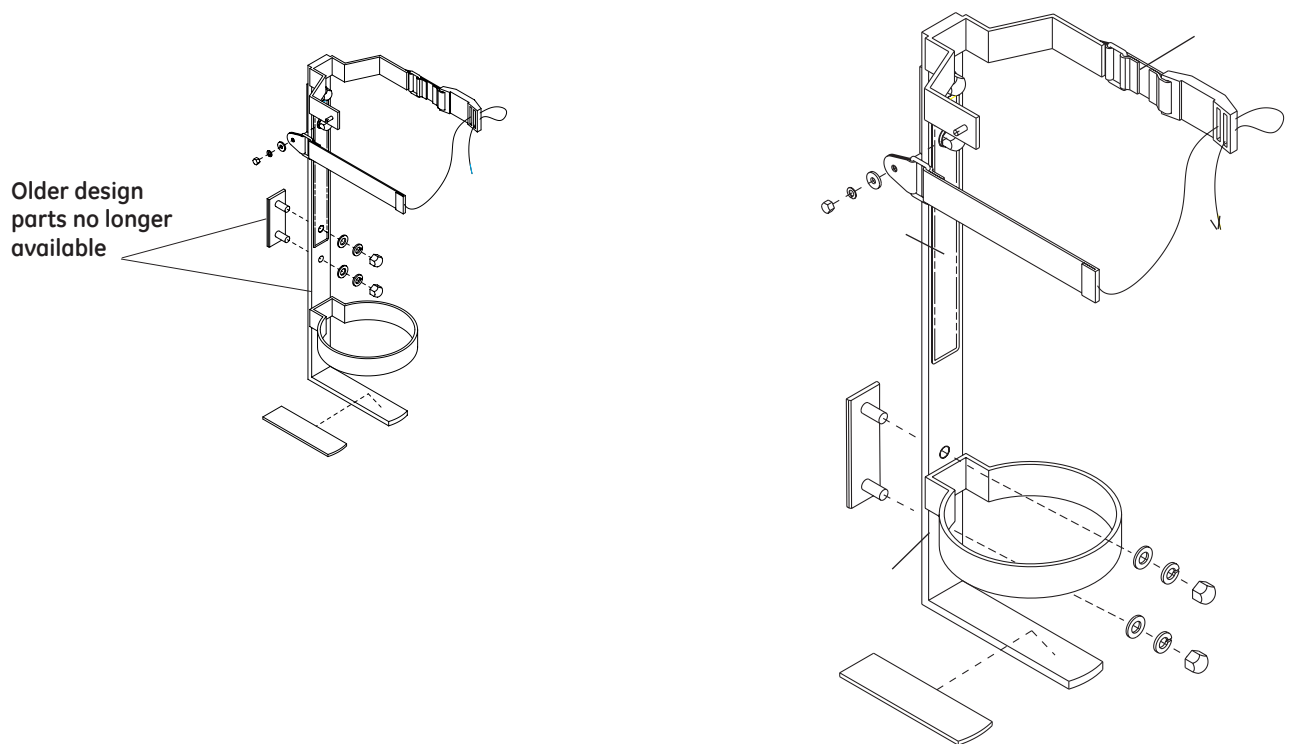

Figure 6-33 E-Cylinder Holder (6600-0836-800)

- 1. Goose neck.....6600-1866-500
- 2. Tubing plate.....6600-1862-500
- 3. Screw cover.....6600-1206-403
- 4. Screw, pan hd.....6600-1213-400
- 5. Mount.....6600-1845-500

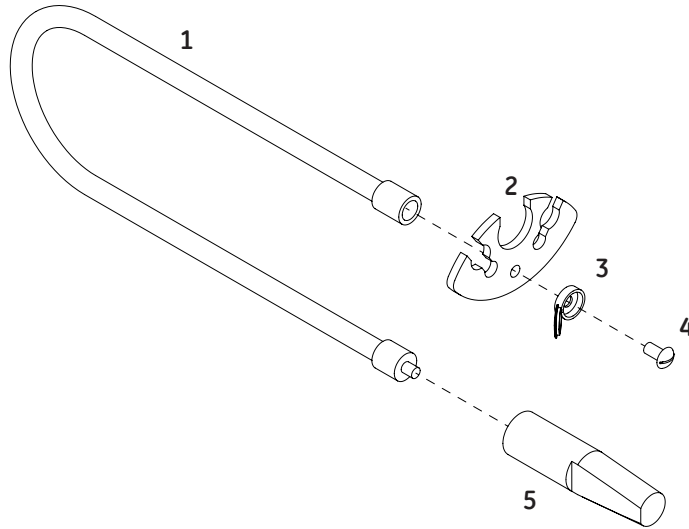

Figure 6-34 Tubing Management Arm (6600-0837-800)

1. Mounting bracket housing.....6600-1541-500
2. Mounting bracket lock.....6600-1542-500
3. Screw, M4 x126600-0853-400
4. DIN rail.....6600-1540-501
5. Spacer6600-1538-500
6. Screw, M8 x 35 Skt Hd.....6600-0852-400

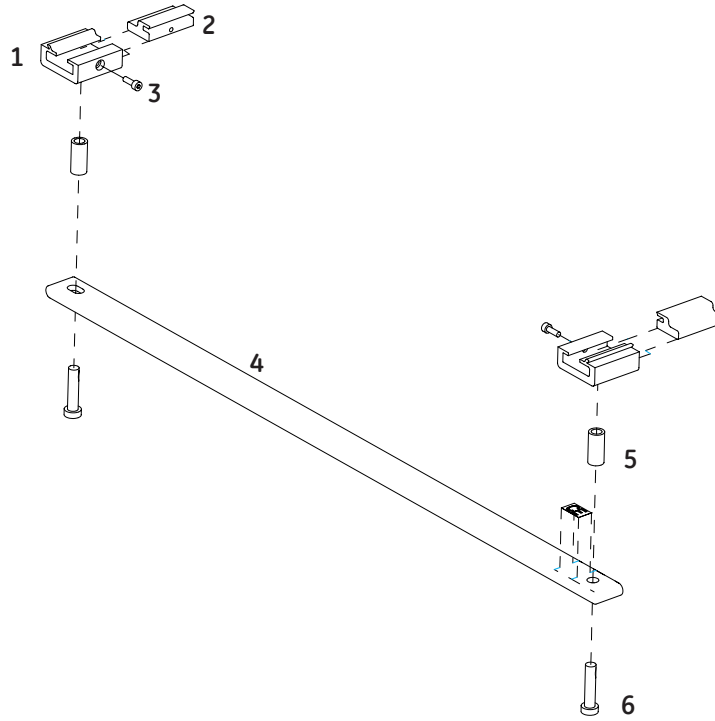

Figure 6-35 Dovetail Mount DIN Rail (6600-0659-803)

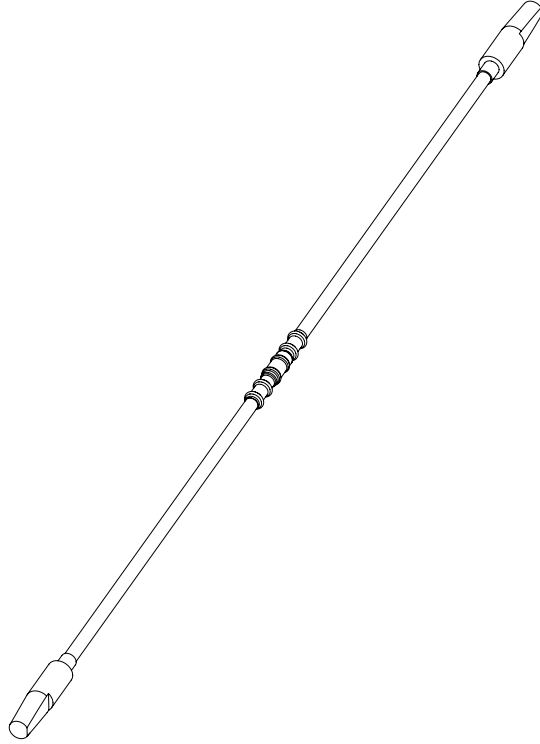

Figure 6-36 Silo Support Assembly (6600-0853-800)

- | | |
|---------------------------------|---------------|
| 1. Screw, 10-32 Button Hd. | 6600-1258-400 |
| 2. Knob | M1081553 |
| 3. Teflon washer..... | 6600-1238-400 |
| 4. (No longer available.) | |
| 5. Knob, block..... | 0217-5335-300 |
| 6. Washer..... | 0202-0095-300 |
| 7. Bushing..... | 6700-0030-400 |
| 8. Label..... | 6600-2497-101 |

NOTE: If you need to replace the upper or lower swing arms, order the entire I.V. pole assembly.

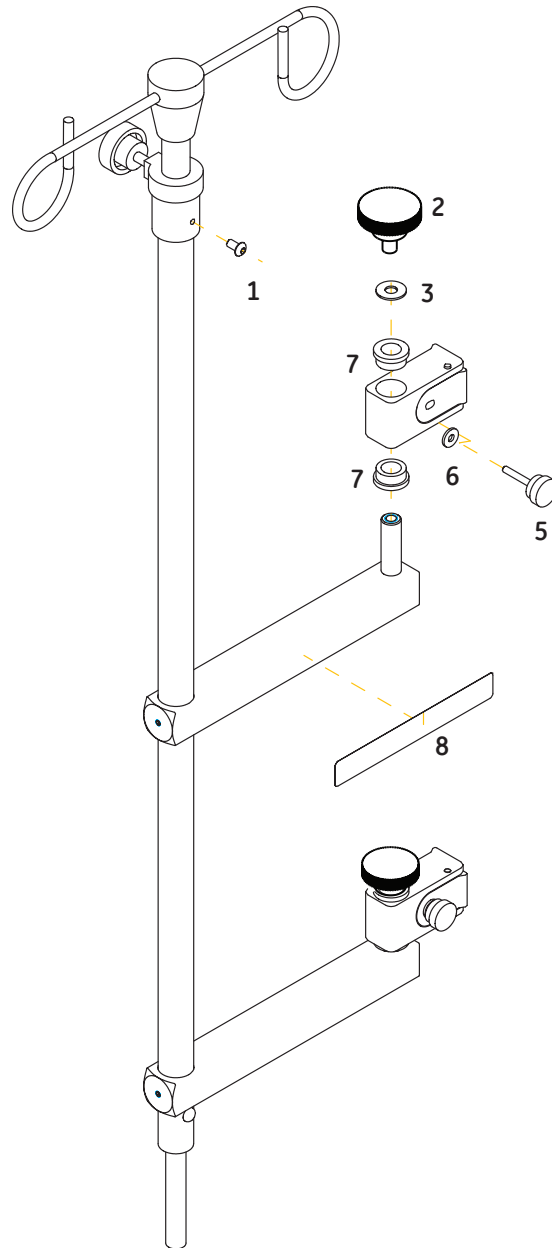

Figure 6-37 Rotating I.V. Pole Assembly (6600-0851-800)

1. Dovetail rail.....	6600-1946-500
2. Bottom end cap.....	6600-0366-500
3. Screw, 4-40 x 1/2, Skt. Hd.....	0144-2117-208
4. Top end cap.....	6600-1239-400
5. Swing arm assembly.....	6600-1516-700
6. Knob.....	M1081553
7. Teflon washer.....	6600-1238-400
8. Knob, block.....	0217-5335-300
9. Washer.....	0202-0095-300
10. Bushing.....	6700-0030-400
11. Lock washer, int. tooth.....	0202-3418-300
12. Screw, 5/16 - 18 Skt. Hd.....	6600-0787-400
13. Label.....	6600-2497-102

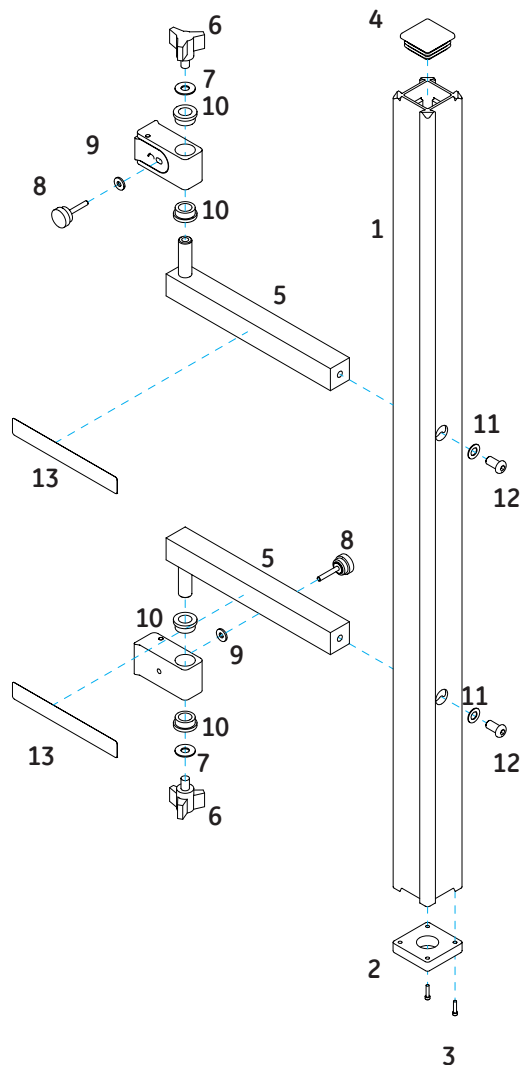
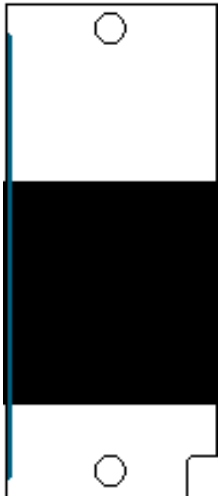

Figure 6-38 Dovetail Extension (6600-0852-800)

6.2 Accessories

Power cord, Europe	6600-0574-612
Power cord, Switzerland.....	6600-0574-621
Power cord, North America	6600-0775-603
Power cord, China.....	M1052154
Power cord, Denmark.....	M1133443
Power cord, India.....	M1153026
Power cord, South Africa	M1161227
Power cord, Israel.....	M1164736
Power cord, Philippines.....	M1194543
Touch-up paint, light gray (Munsell .16GY8.56-0.44 chroma)	6600-0714-200
Patient probe, disposable (10 pcs.).....	6600-0873-700
Patient probe, disposable (50 pcs.).....	6600-0874-700
Patient probe, reusable	6600-0875-700
Porthole wristlets (8 pcs.).....	6600-0211-850
Air intake filter (10 pcs.).....	6600-0207-850
Fabric hood cover	6600-0825-800
Internal shelf-	
front right (SE) and rear left (NW)	6600-1793-500
rear left (NE) and front right (SW)	6600-1794-500
Scale	Call your GE sales representative or distributor.
Oscillator port cover.....	6600-0838-800

6.3 Labels



6600-2325-101



6600-2325-102



6600-2325-103

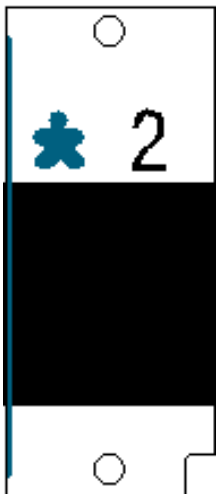

6600-2325-107



6600-2325-104



6600-2325-108



Servo O2 maximum pressure labels:

kPa.....6600-2448-101

psi.....6600-2448-102



6600-2328-101

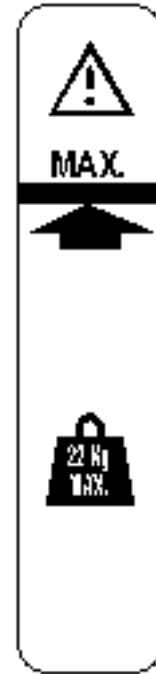

6600-2347-101



6600-2343-101



6600-1839-101

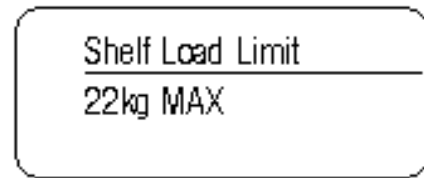

6600-1941-101

OHMEDA REF: 6600-0851-800 Swiveling IV Pole
 Medical
 Ohmeda Medical
 Laurel MD 20723
 USA

CE 0086

OHMEDA REF: 6600-0852-800 Dove Tail Rail
 Medical
 Ohmeda Medical
 Laurel MD 20723
 USA

CE 0086

Weight limit warning labels:

IV Pole6600-2497-101

Dovetail Rail6600-2497-102



Giraffe OmniBed branding label.....M1198103



Bed up/down pedal switch label.....6600-2552-101

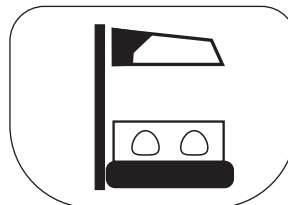
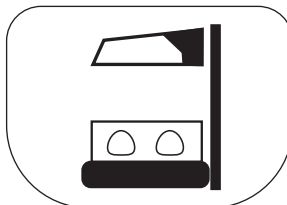

Canopy pedal switch label.....6600-2552-102

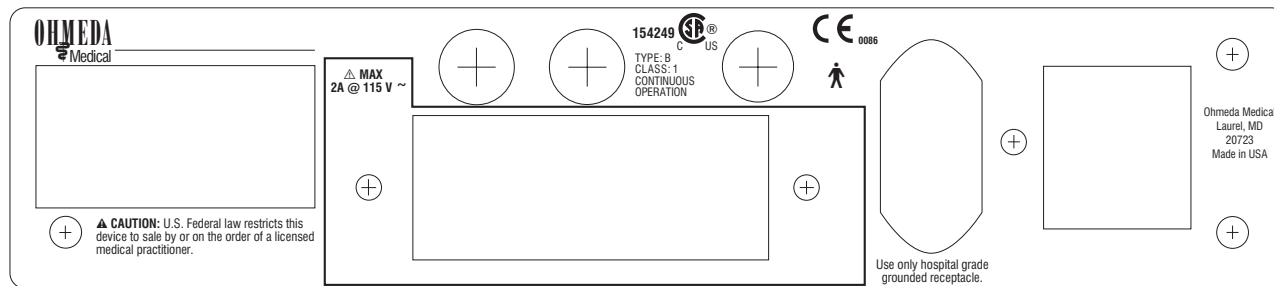

6600-2345-101

Rating label 115V.....6600-2345-101

Rating label 220V.....6600-2345-102

Rating label 100V.....6600-2345-103

▲ WARNING:

Oxygen concentrations may vary with fan speed. Use ONLY a servo control oxygen delivery system.

O2 warning labels:

Chinese.....	6600-2341-113
Croatian.....	M1144126
Czech.....	M1117737
Danish.....	6600-2341-117
Dutch.....	6600-2341-110
English.....	6600-2341-101
Estonian.....	M1114975
Finnish.....	M1061656
French.....	6600-2341-102
German.....	6600-2341-104
Greek.....	6600-2341-109
Italian.....	6600-2341-105
Japanese.....	6600-2341-107
Korean.....	M1125065
Lithuanian.....	M1149784
Norwegian.....	6600-2341-118
Polish.....	M1114972
Portuguese.....	M1090505
Romanian.....	M1120365
Russian.....	M1125063
Serbian.....	M1139486
Slovakian.....	M1139361
Spanish.....	6600-2341-103
Swedish.....	6600-2341-106
Turkish.....	M1114967

▲ WARNING: Always lower the bed to its lowest position before mounting accessories to ensure proper clearance with the caster legs and the floor.

Accessory mounting warning labels

Chinese, Danish, Dutch, English, French, German, Italian, Japanese, Norwegian, Portuguese, Spanish, and Swedish.....	6600-2748-100
Finnish.....	M1061661
Czech, Estonian, Greek, Korean, Polish, Romanian, Russian, Serbian, Slovakian, and Turkish.....	M1114982
Croatian and Lithuanian.....	M1144129

▲ WARNING: When performing **ECMO** (Extracorporeal Membrane Oxygenation) or **HFOV** (High Frequency Oscillatory Ventilation), disable Elevating Base in set up screen by selecting wrench icon.



ECMO warning labels:

Dutch, English, French, German, Italian, and Spanish.....	6600-2546-101
Danish, Chinese, Japanese, Norwegian, Russian, and Swedish.....	6600-2546-102
Czech, Estonian, Polish, Portuguese, Romanian, and Turkish	M1093199
Greek, Korean, Serbian, and Slovak.....	M1125076
Croatian, and Lithuanian	M1144131
Finnish.....	M1061658



WARNING: Disconnect any oxygen supply to the device when using electro-surgical unit.

Disconnect O2 warning labels:

Chinese, Czech, Danish, Dutch, English, Estonian, French, German, Greek, Italian, Japanese, Korean, Norwegian, Polish, Portuguese, Romanian, Russian, Serbian, Slovakian, Spanish, Swedish, and Turkish	6600-2540-101
Finnish.....	M1061666
Croatian and Lithuanian	M1144167

▲ Warning: Ensure porthole is securely latched. Do not open porthole when tubing is in place.

Porthole warning label.....	6600-2658-101
-----------------------------	---------------

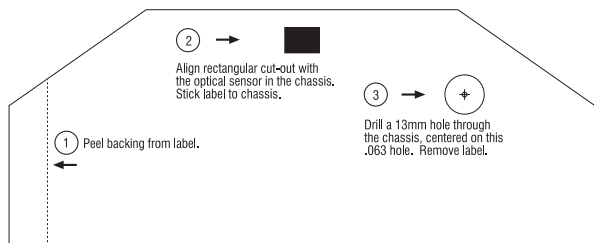

Chassis vent Servo O2 template label.....	6600-2488-100
---	---------------

6.4 PCB Layouts

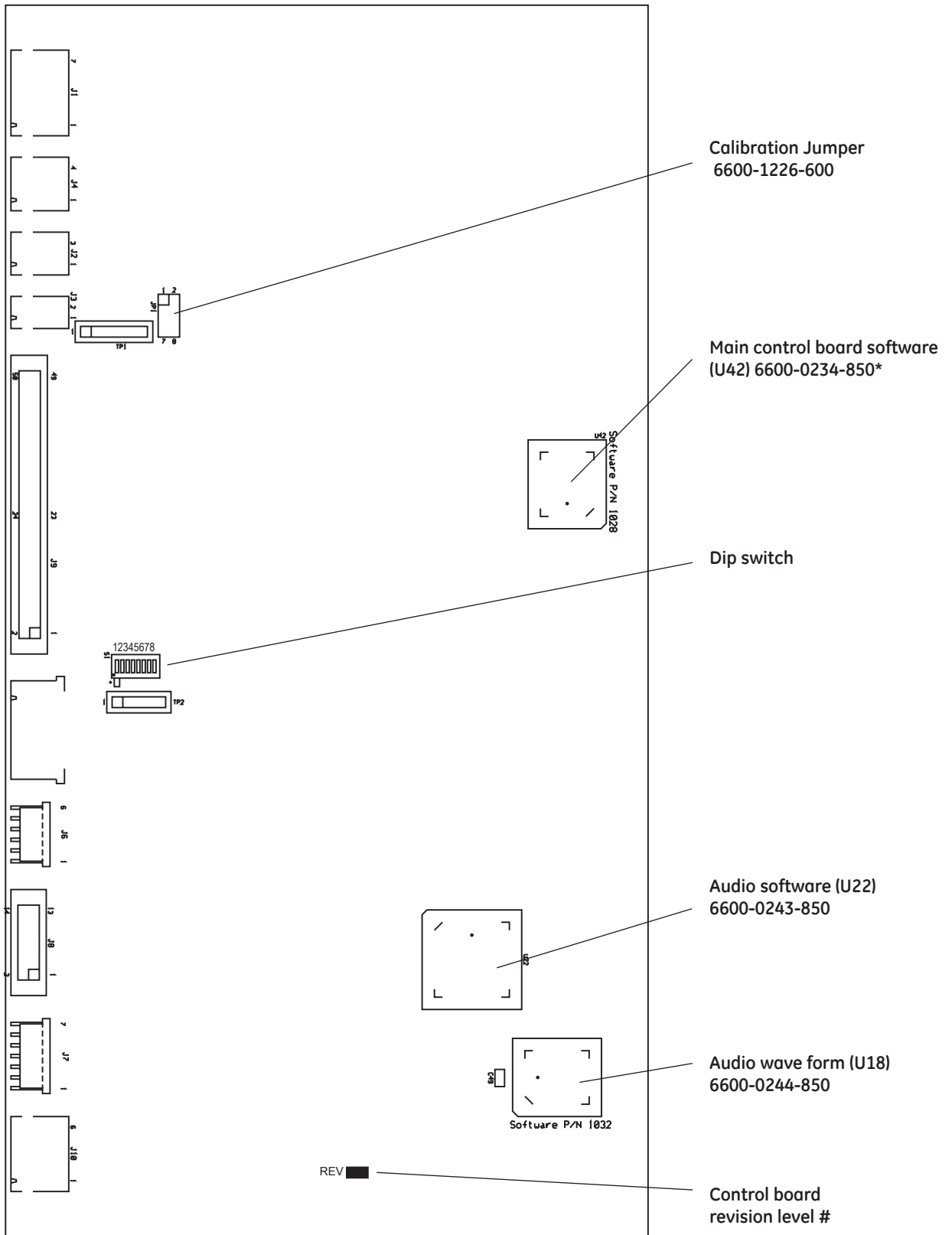

*Kit Includes display driver software.

Figure 6-39 Control Board (6600-0212-850)

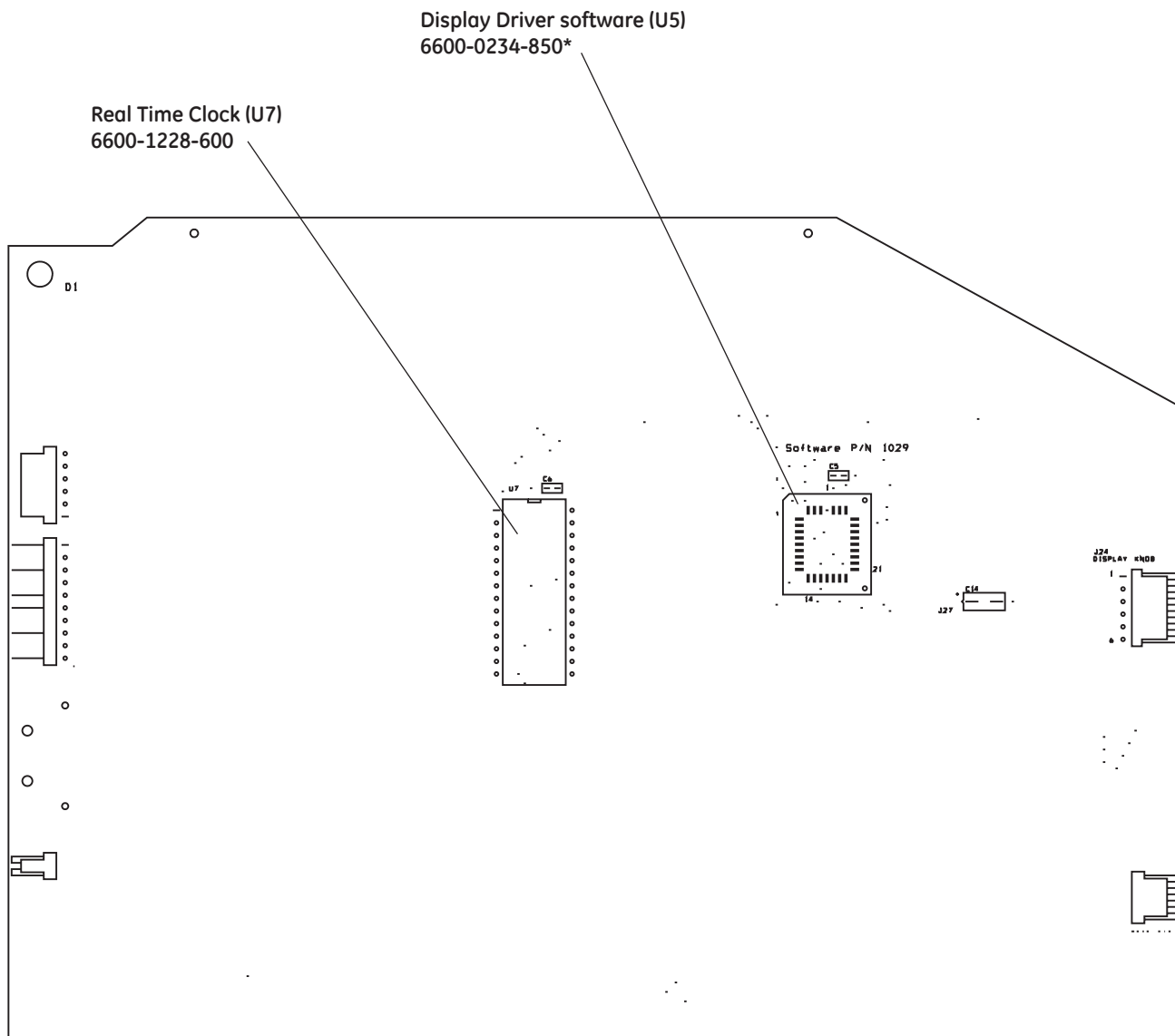

*Kit Includes main control software.

Figure 6-40 Display Driver Board (6600-0213-850)

Board Assembly
Revision Number

Fuse 3.15 amp
6600-0878-600

Fuse 120V 2 amp
6600-0877-600
Fuse 230V 1 amp
6600-0882-600

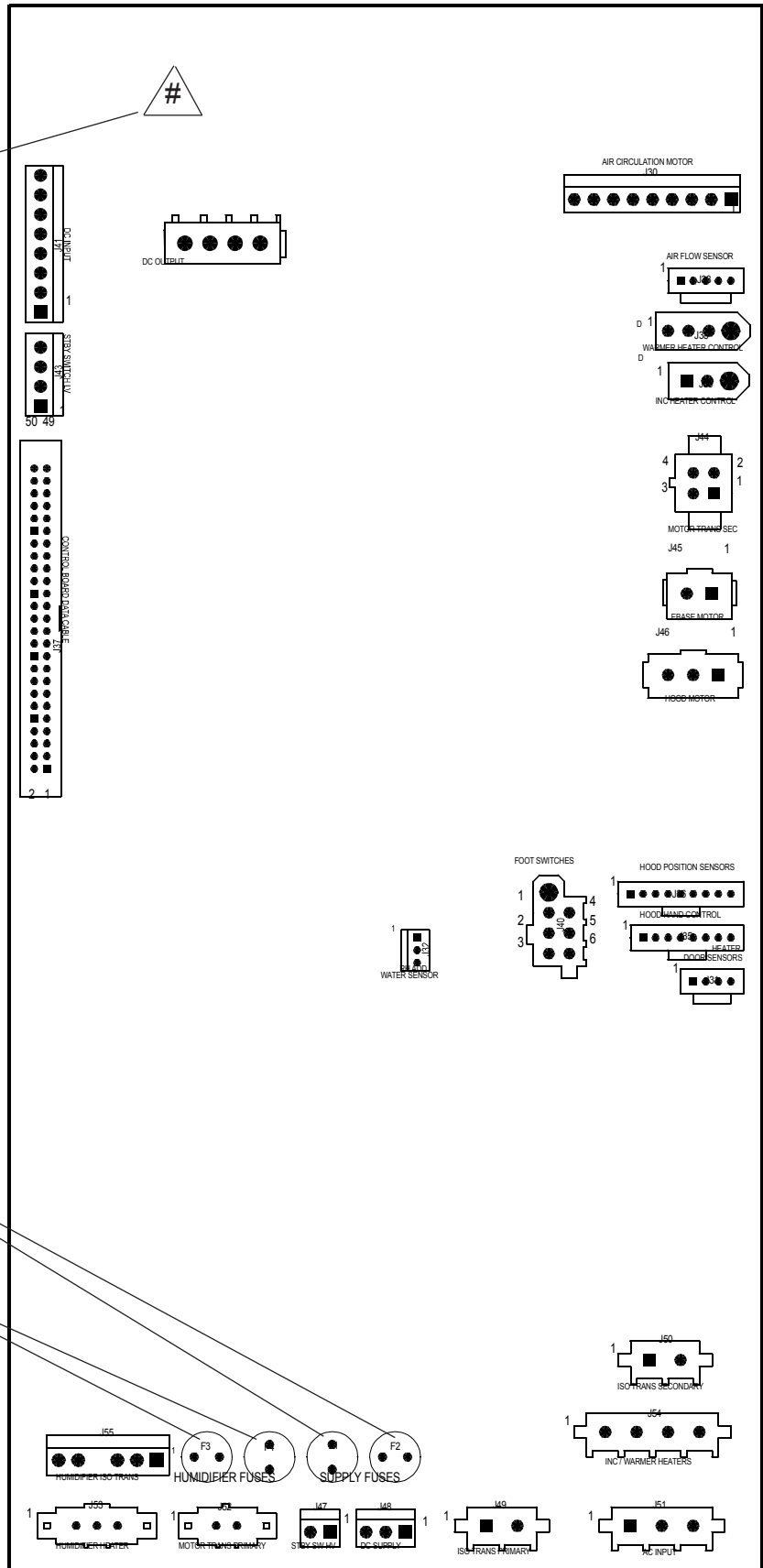

Figure 6-41 Relay Board (6600-0214-850) Revision Level 10 or Higher

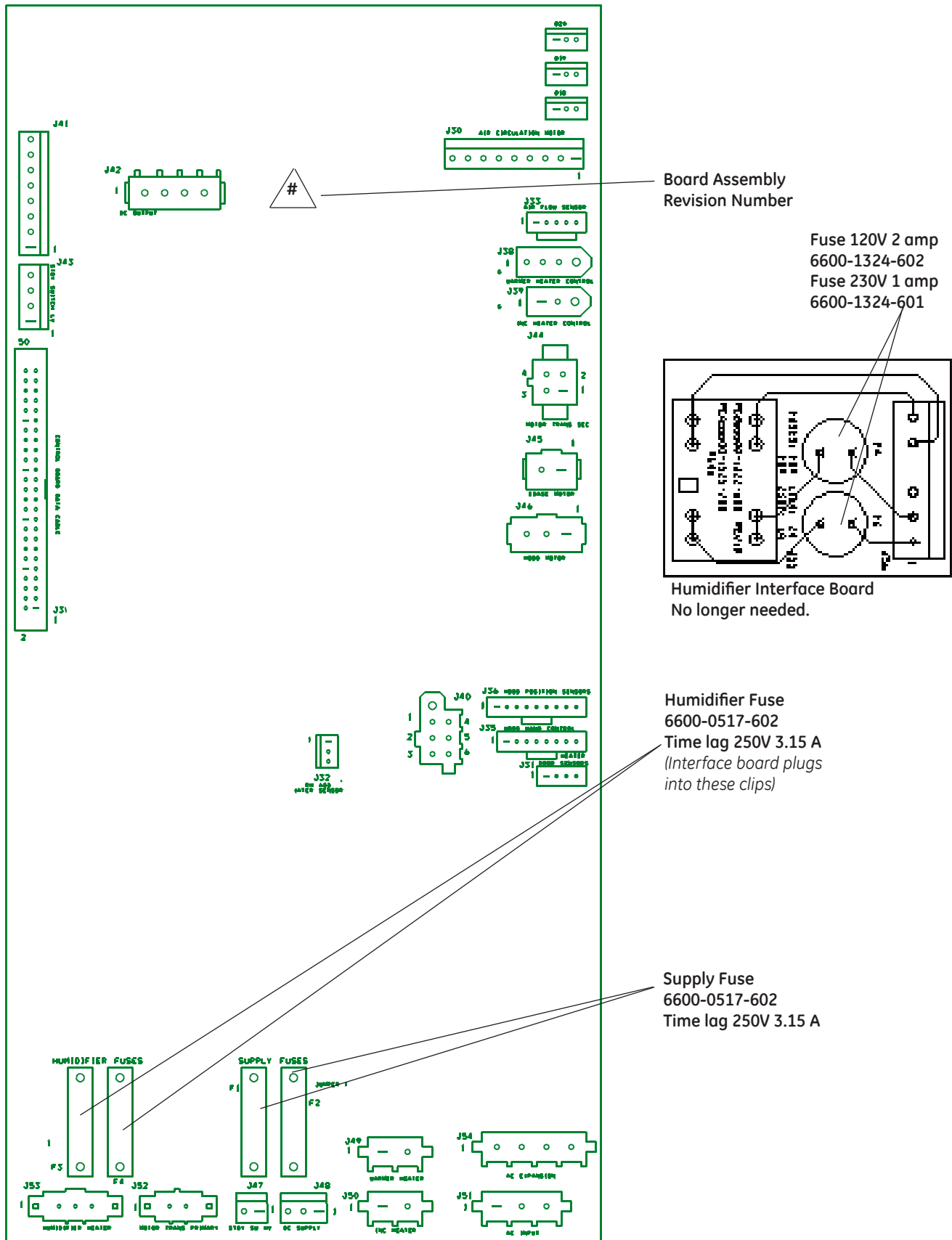

Figure 6-42 Relay Board (6600-0214-850) Revision Level 9 or Lower

6.5 Wiring Diagrams

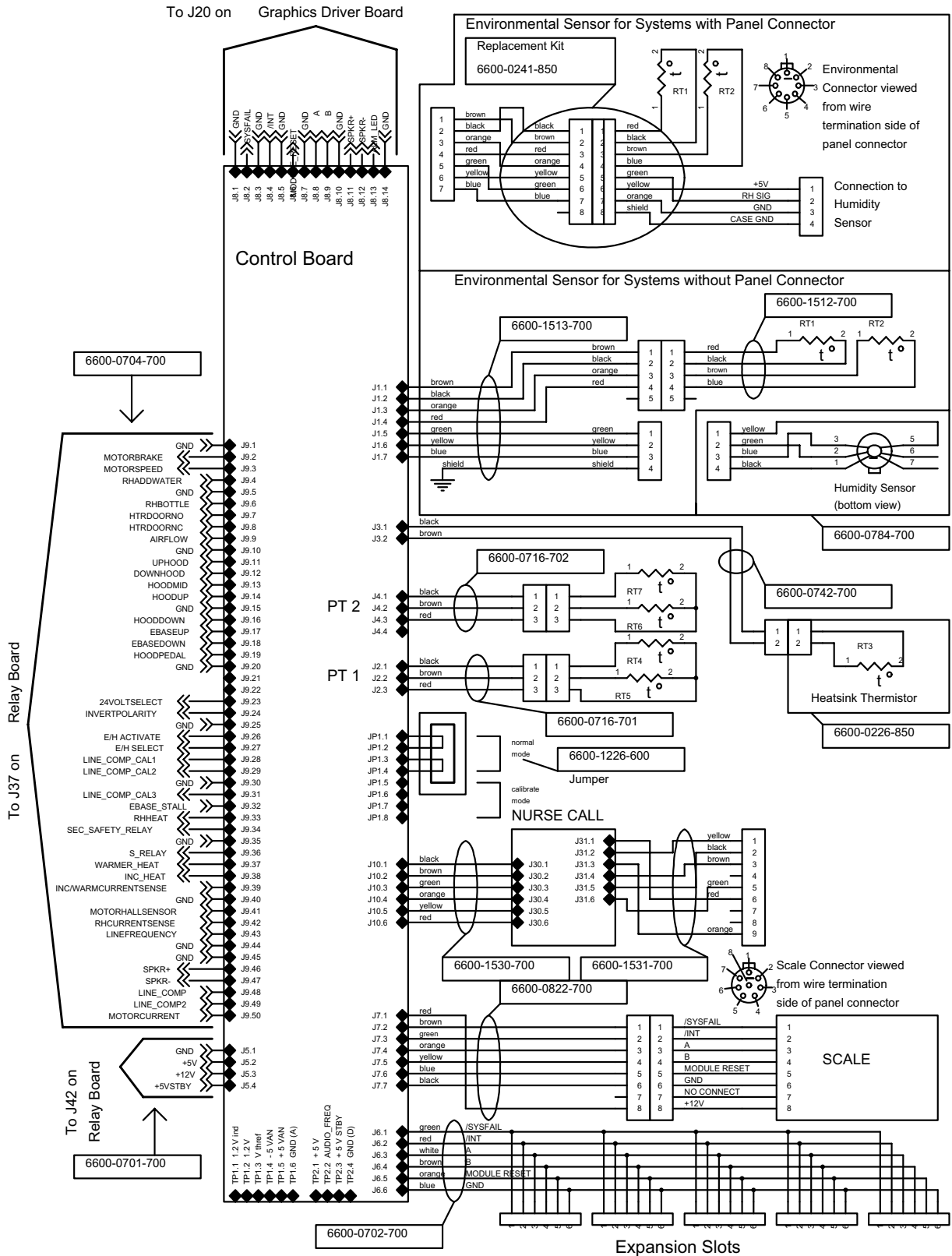
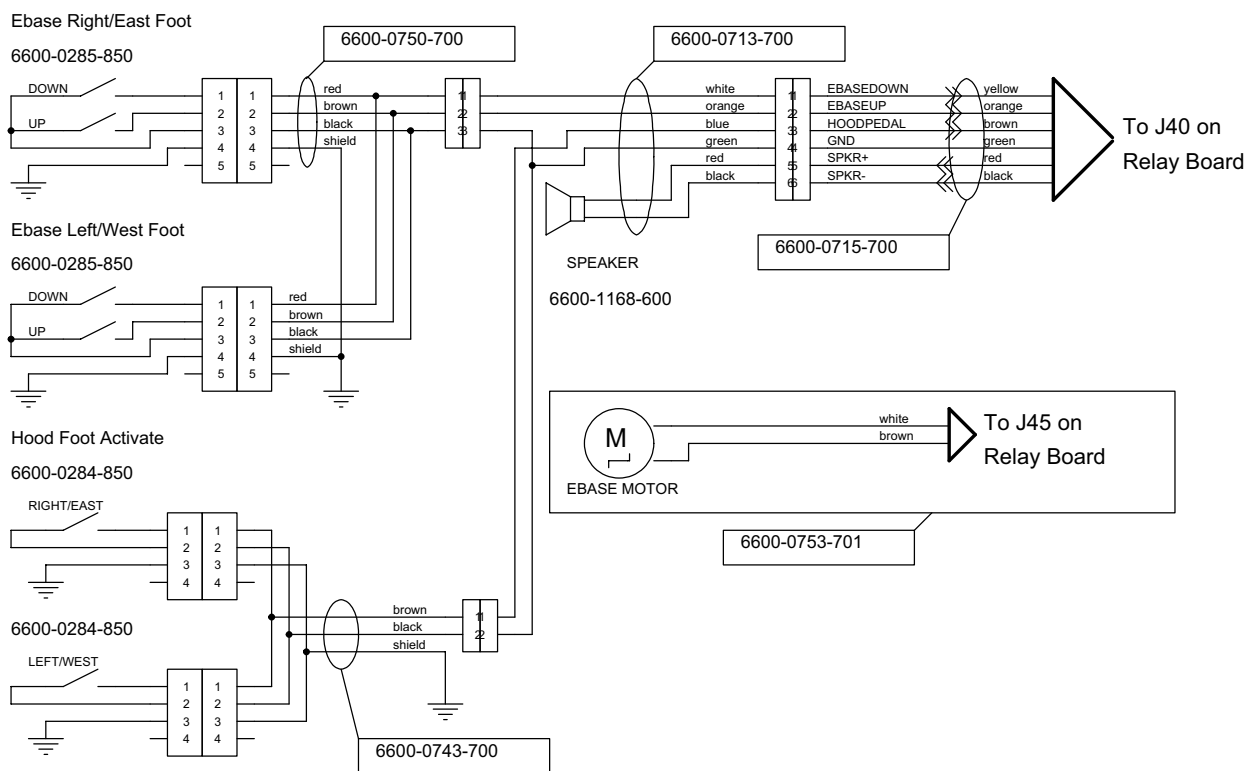

Figure 6-43 Wiring Diagram: Control Board

Base Pedestal



Rail Components

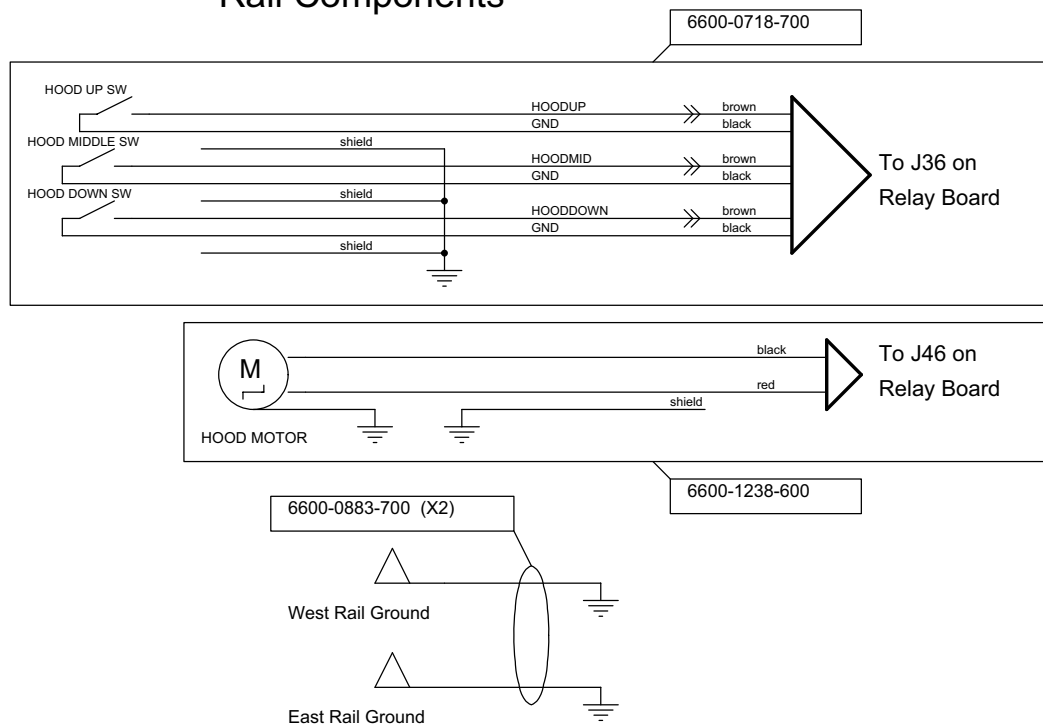

Figure 6-44 Wiring Diagram: Elevating Base and Canopy Lift Rails

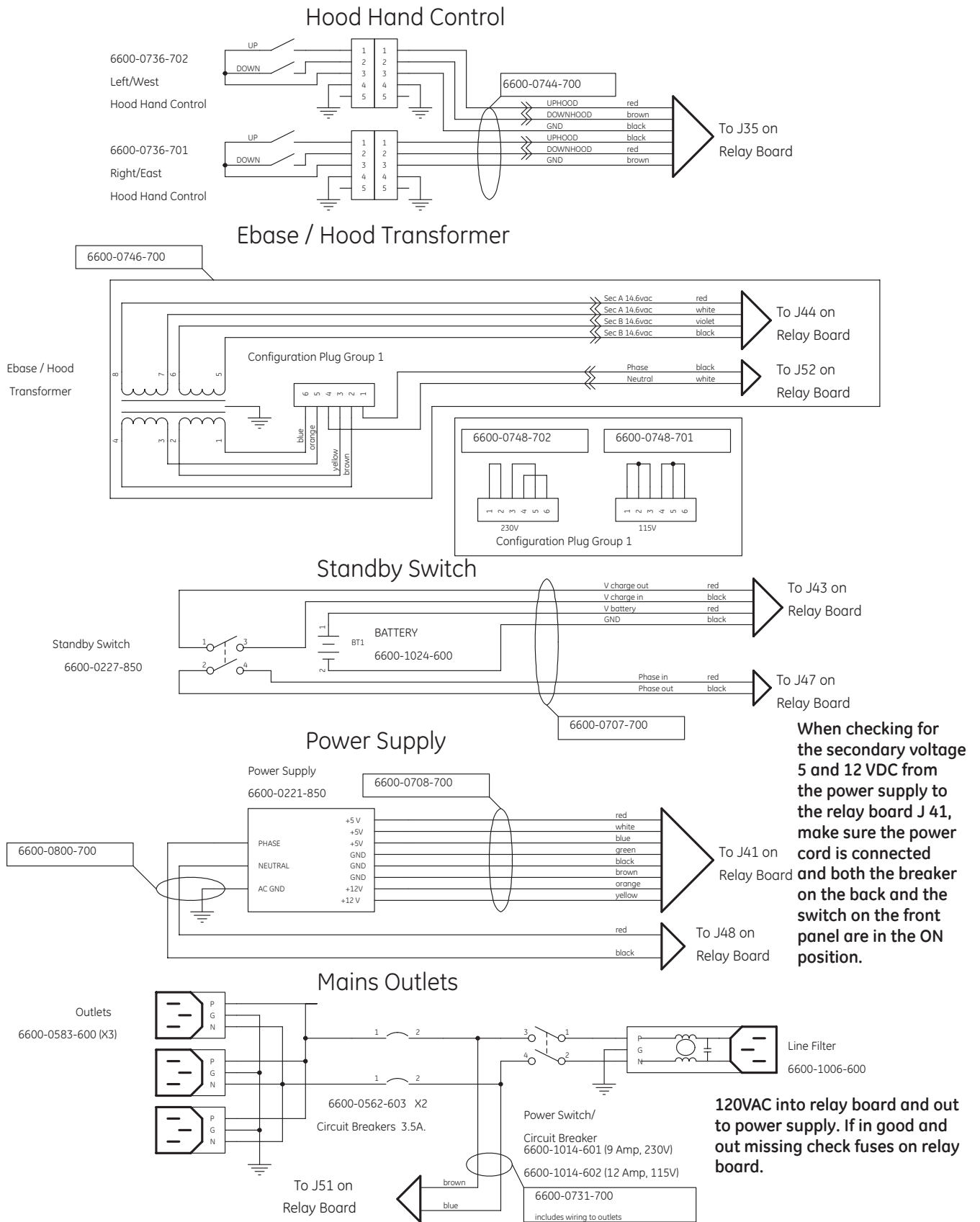

Figure 6-45 Wiring Diagram: Electrical Enclosure

Alpha Numeric Pad

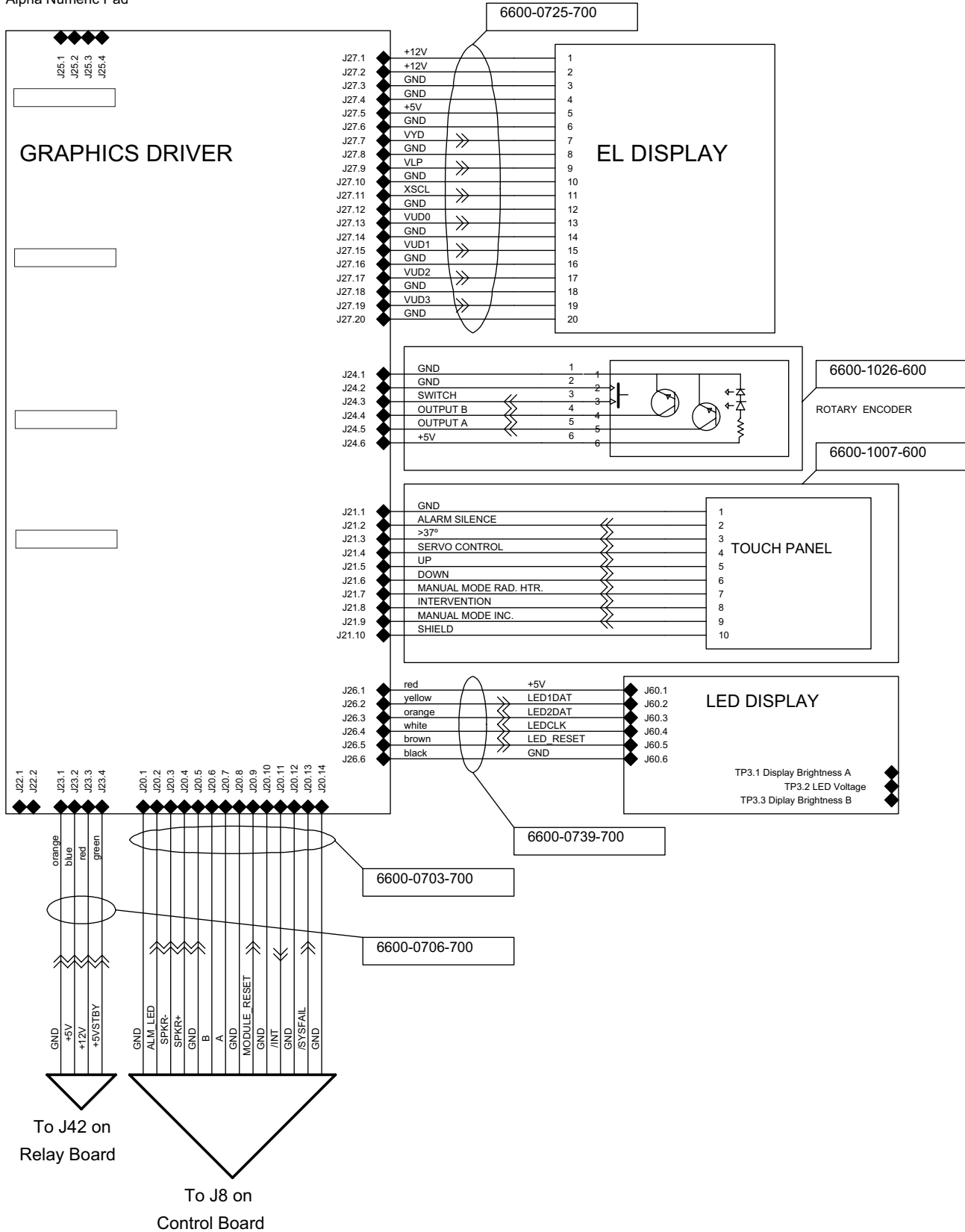
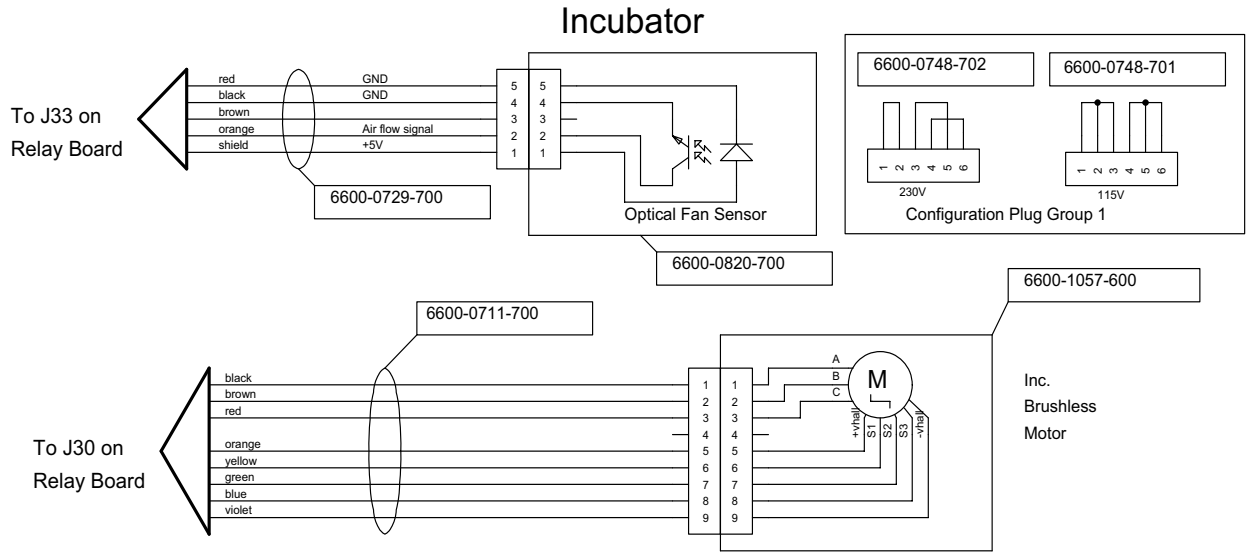

Figure 6-46 Wiring Diagram: Graphics Display



Note:

For Systems With Revision 10 and above Relay Boards:

The two position connector connects to the two position connector on harness

6600-0623-700. See the Radiant Warmer w/rev 10 and above Relay Board section of the Wiring Diagram. The configuration plug is always 6600-0748-701 (115 VAC).

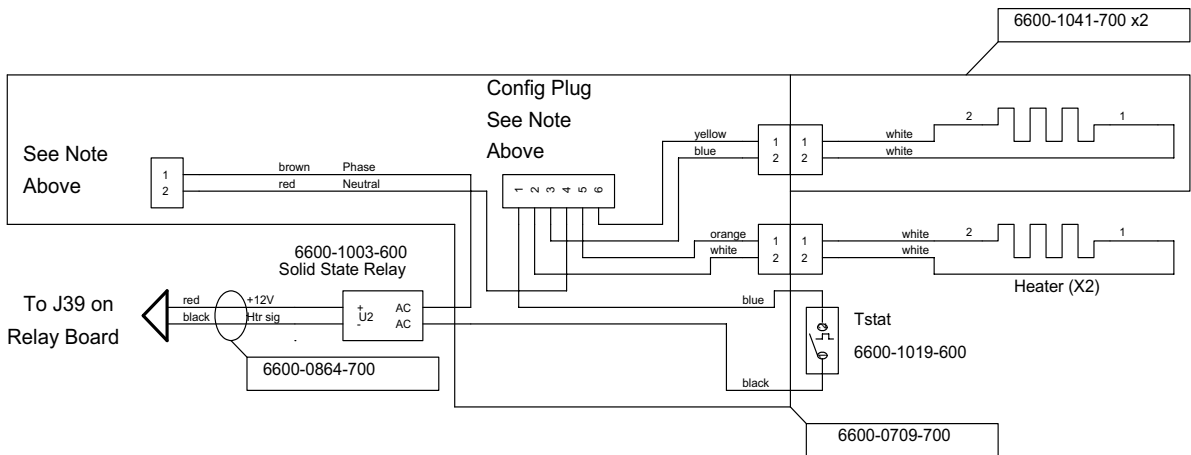

Humidifier Add Water Thermostat and Bottle

Position Sensor

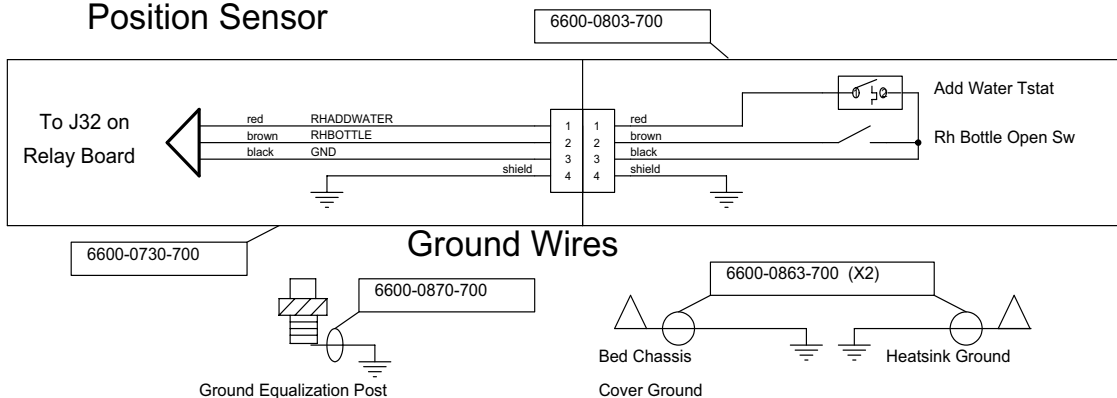
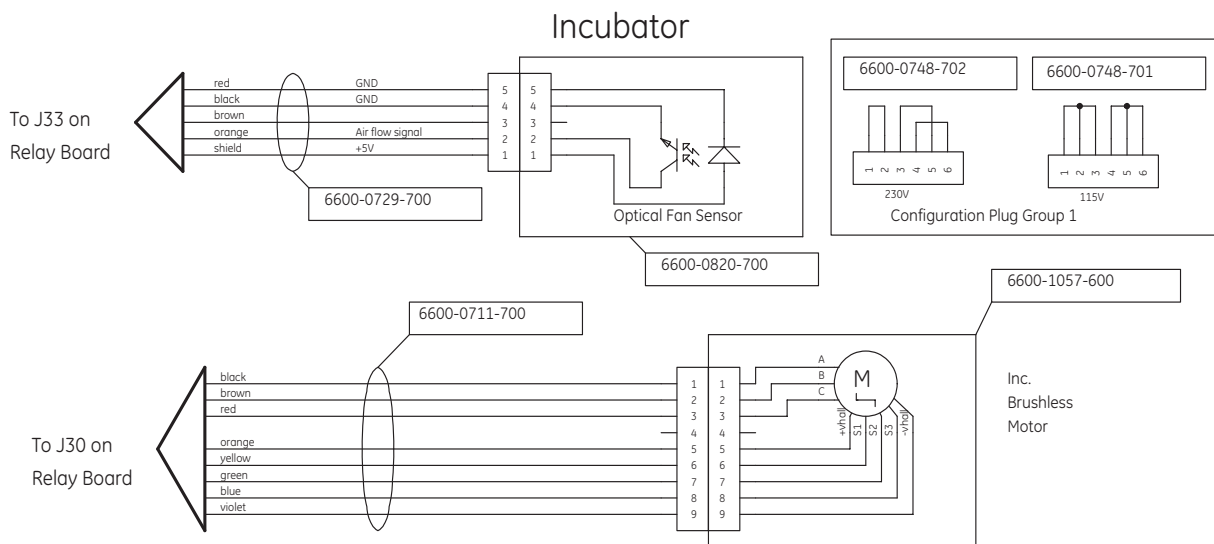
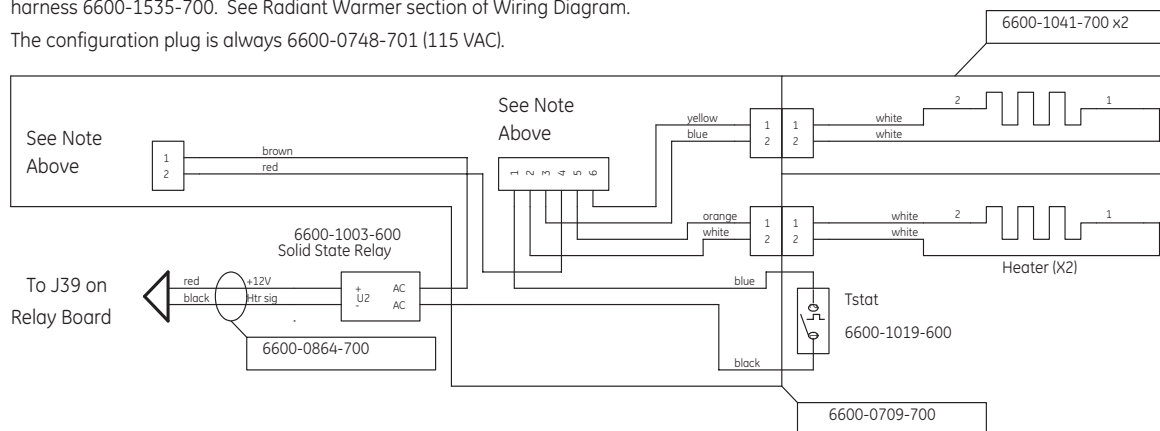

Figure 6-47 Wiring Diagram: Incubator Relay Board Rev 10 or Higher



Note:
 The two position connector connects to the two position connector on harness 6600-1535-700. See Radiant Warmer section of Wiring Diagram.
 The configuration plug is always 6600-0748-701 (115 VAC).



Humidifier Add Water Thermostat and Bottle Position Sensor

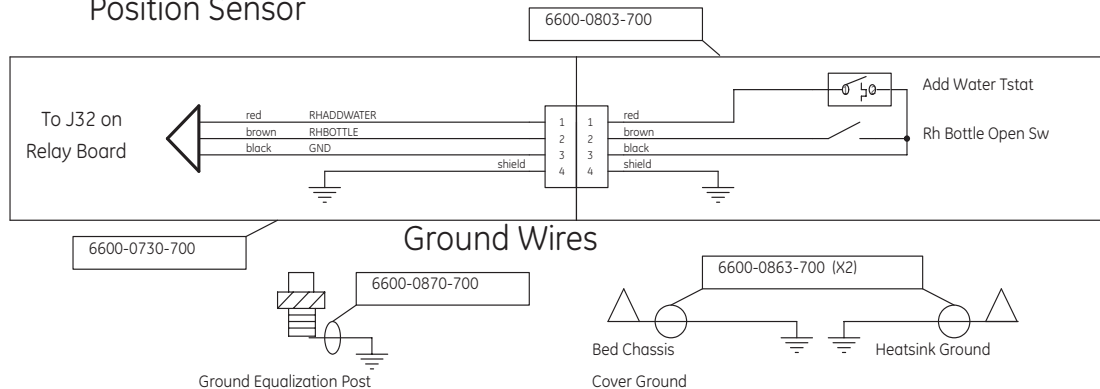

Figure 6-48 Wiring Diagram: Incubator Relay Board 9 or Lower

Radiant Warmer

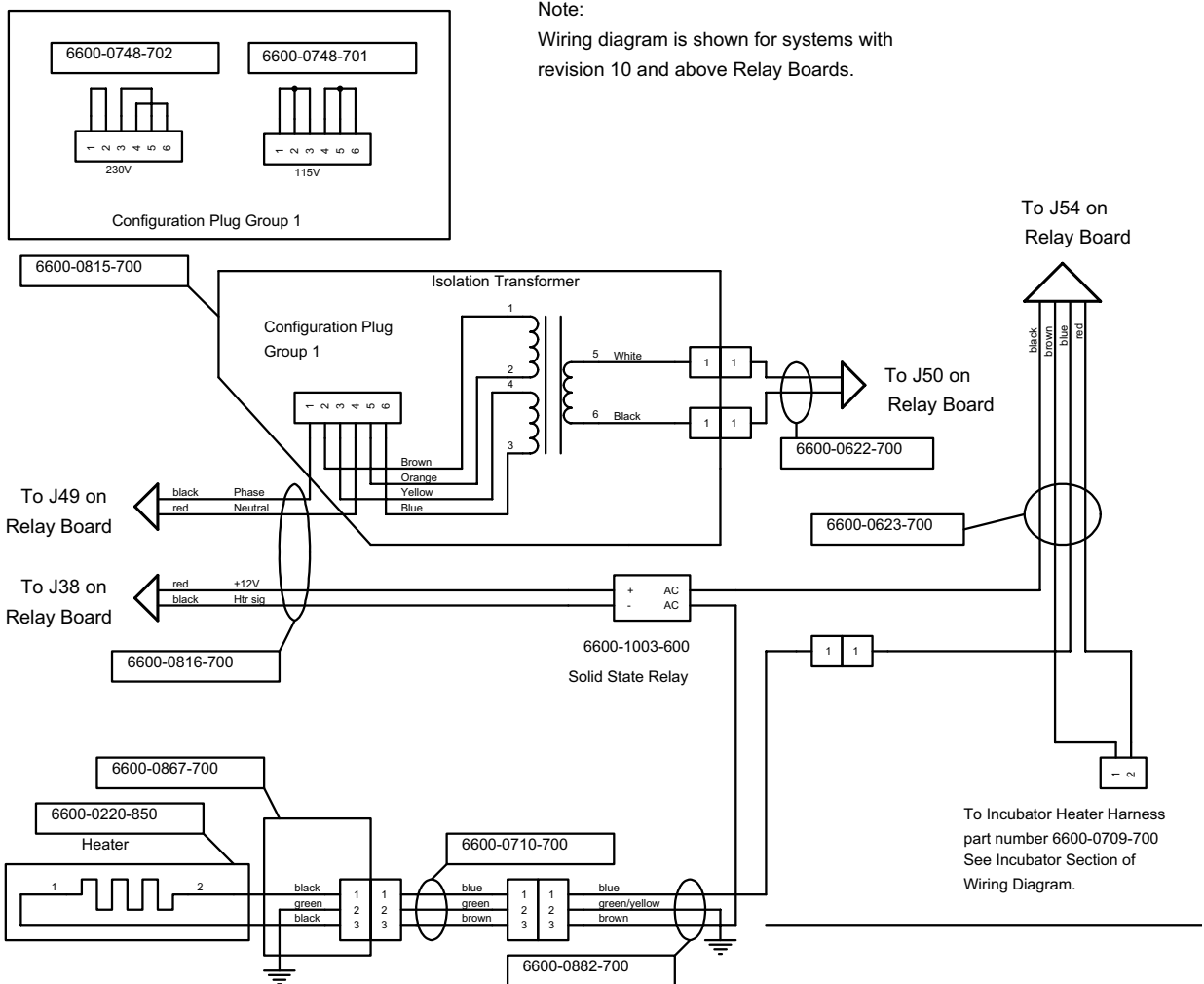
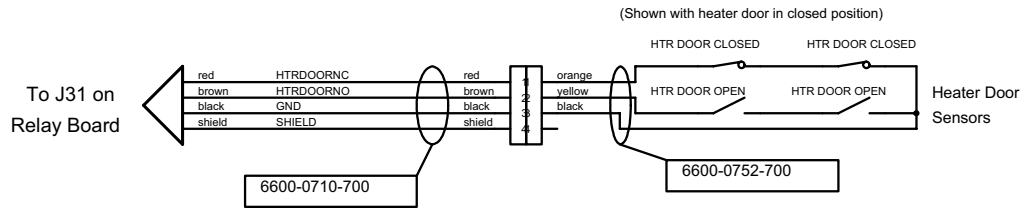

Figure 6-49 Wiring Diagram: Radiant Heater Relay Board 10 or Higher

Radiant Warmer

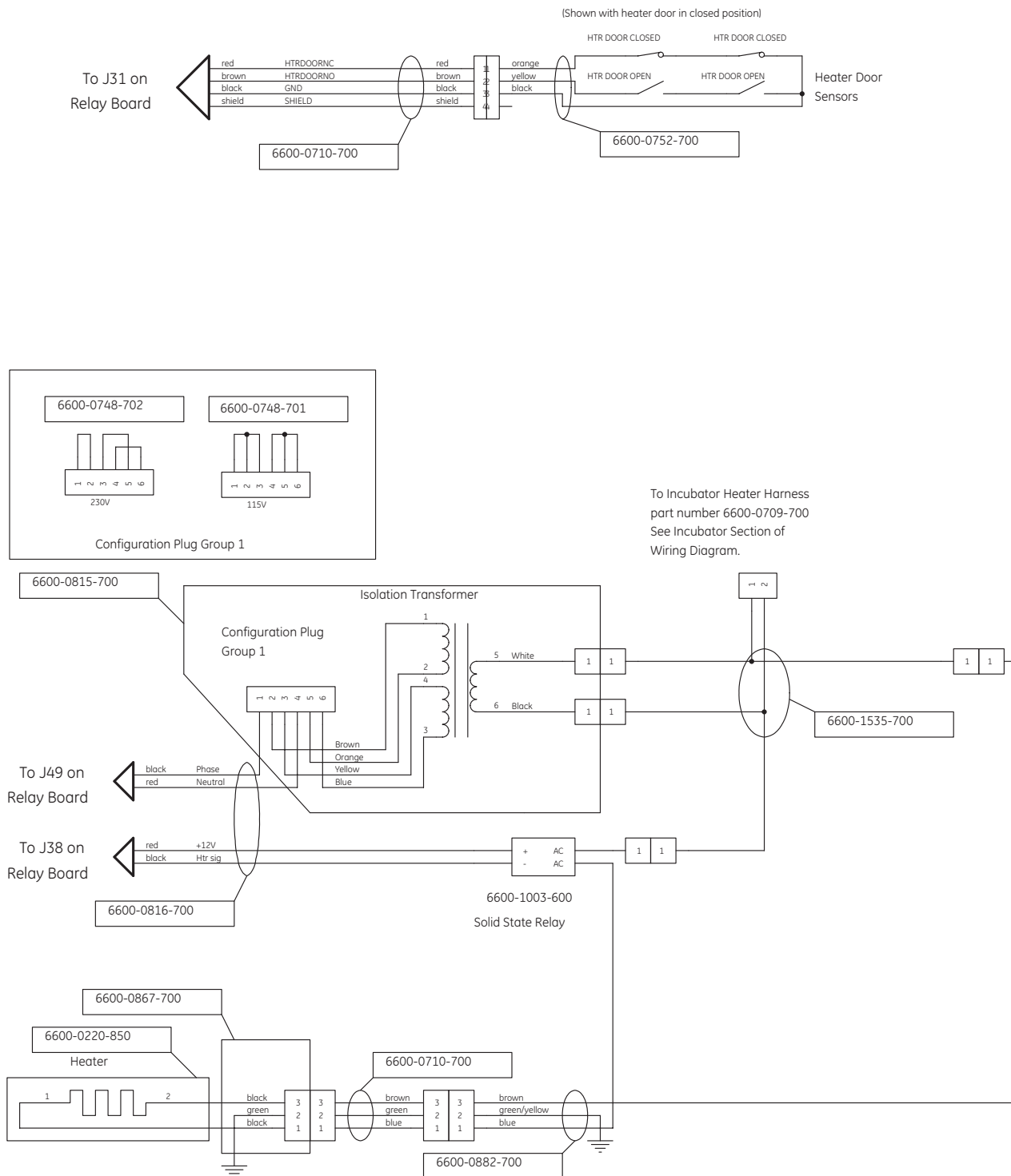

Figure 6-50 Wiring Diagram: Radiant Heater Relay Board 9 or Lower

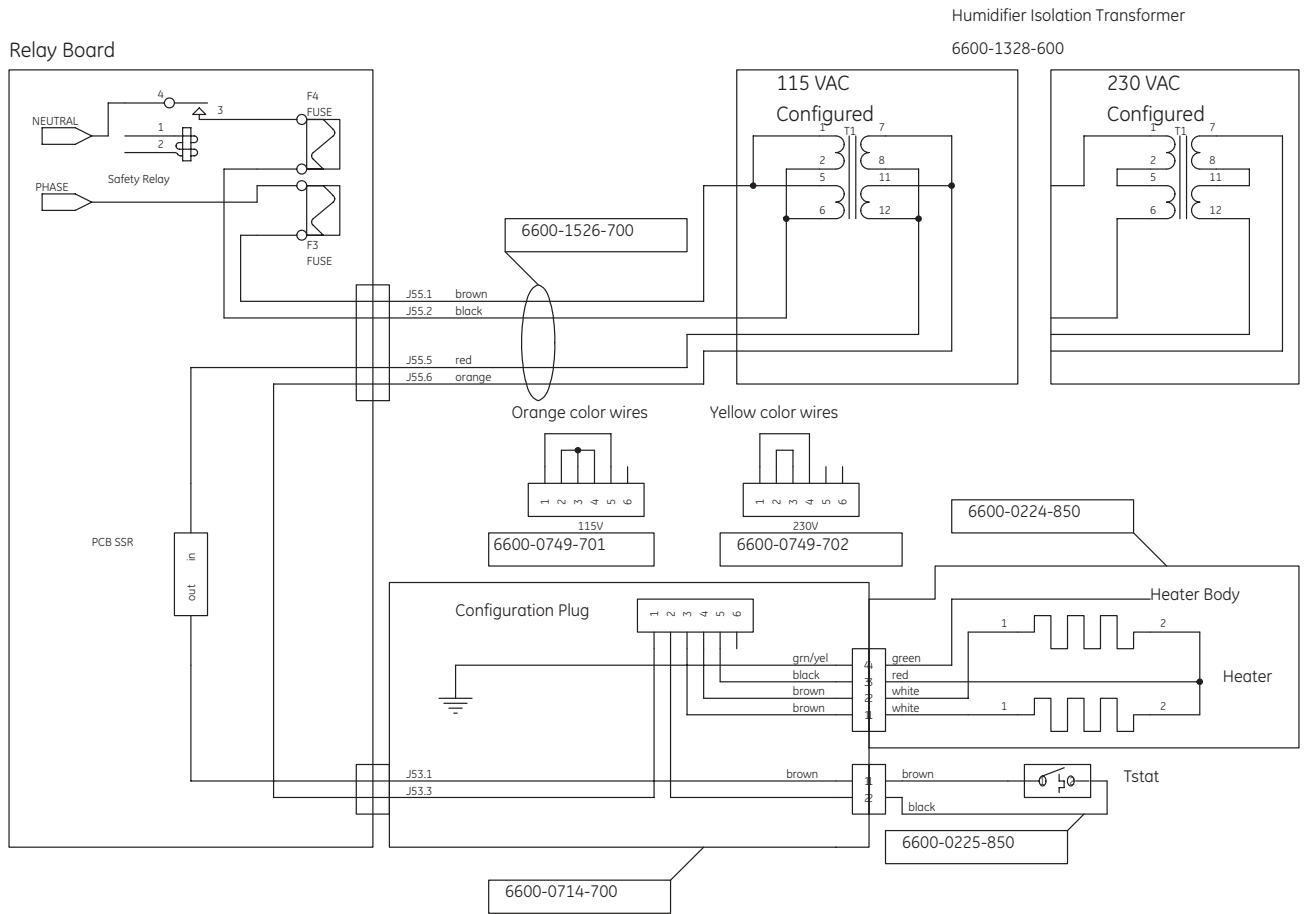

Figure 6-51 Wiring Diagram: Servo Humidifier Relay Board 10 or Higher

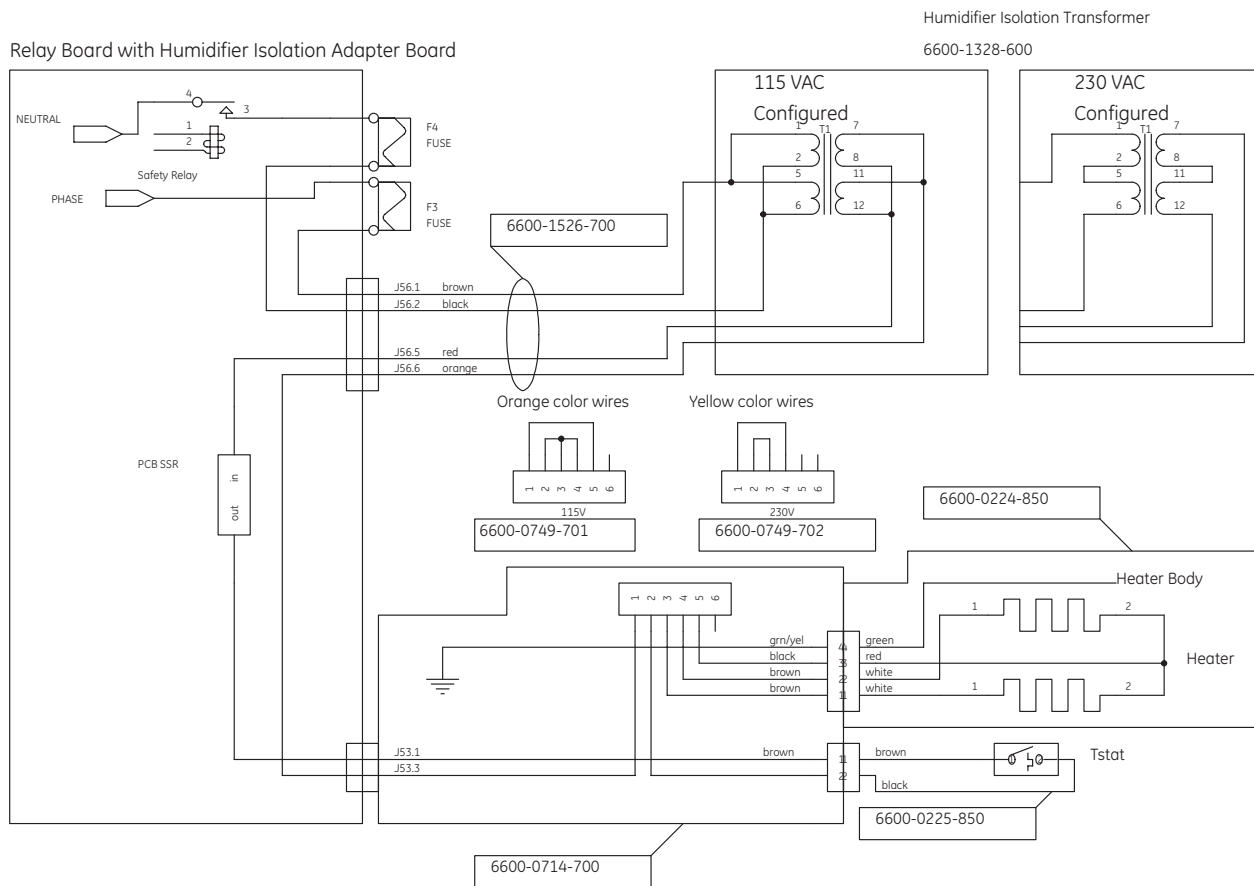

Figure 6-52 Wiring Diagram: Servo Humidifier Relay Board 9 or Lower

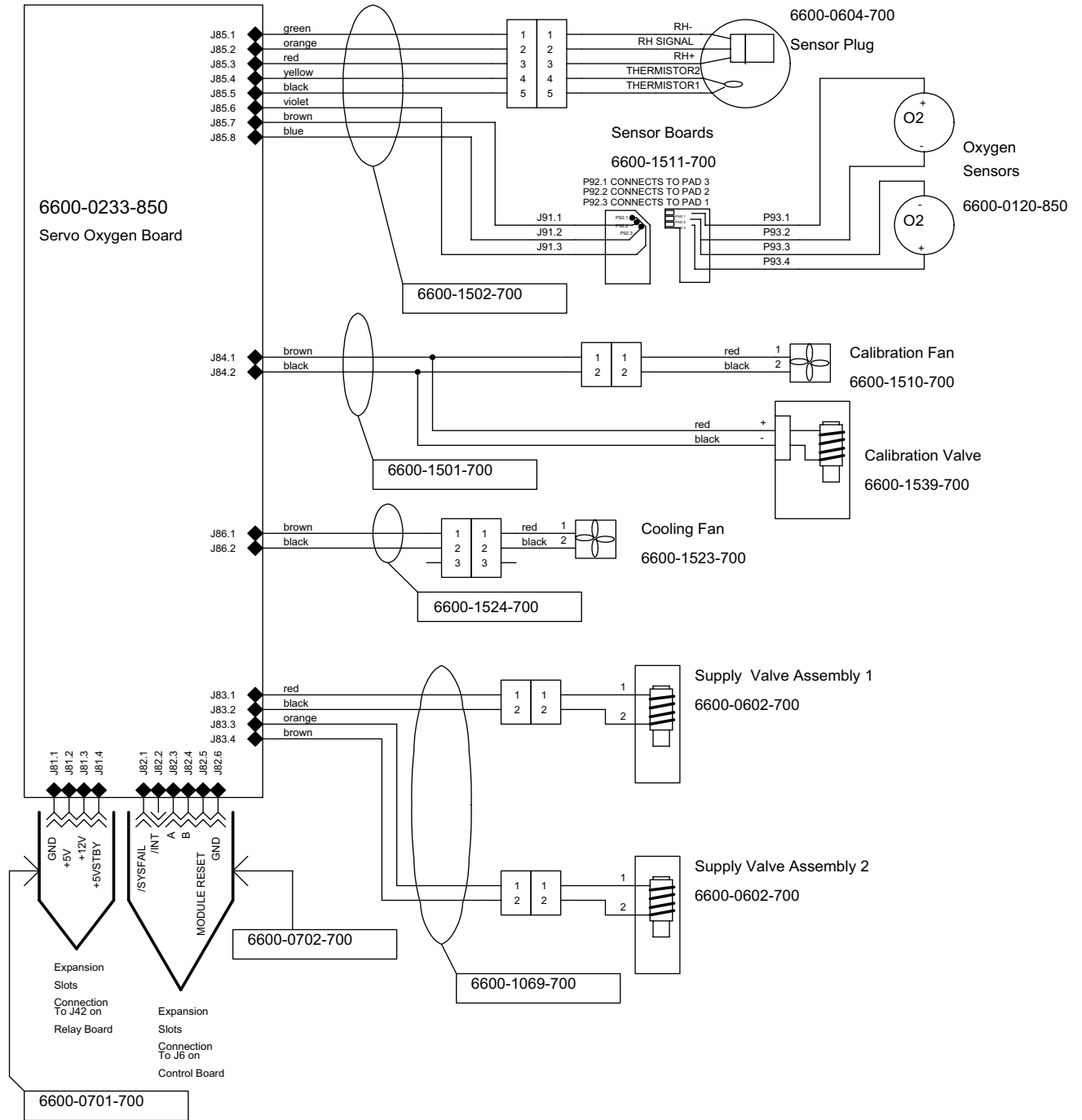

Figure 6-53 Wiring Diagram: Servo Control Oxygen

Appendix A: Compartment and Skin Probe Characteristics

Temp °C	Res. Ohms
29.9	8071.2
30.0	8036.5
30.1	8002.0
30.2	7967.6
30.3	7933.4
30.4	7899.4
30.5	7865.6
30.6	7831.9
30.7	7798.3
30.8	7765.0
30.9	7731.7
31.0	7698.7
31.1	7665.8
31.2	7633.1
31.3	7600.5
31.4	7568.1
31.5	7535.9
31.6	7503.8
31.7	7471.8
31.8	7440.0
31.9	7408.4
32.0	7376.9
32.1	7345.6
32.2	7314.4
32.3	7283.4
32.4	7252.5
32.5	7221.8
32.6	7191.2
32.7	7160.8
32.8	7130.5
32.9	7100.4
33.0	7070.4
33.1	7040.5
33.2	7010.8
33.3	6981.3
33.4	6951.8
33.5	6922.6
33.6	6893.4
33.7	6864.4
33.8	6835.5
33.9	6806.8

Temp °C	Res. Ohms
34.0	6778.2
34.1	6749.8
34.2	6721.5
34.3	6693.3
34.4	6665.3
34.5	6637.3
34.6	6609.6
34.7	6581.9
34.8	6554.4
34.9	6527.0
35.0	6499.8
35.1	6472.6
35.2	6445.7
35.3	6418.8
35.4	6392.1
35.5	6365.4
35.6	6339.0
35.7	6312.6
35.8	6286.4
35.9	6260.3
36.0	6234.3
36.1	6208.4
36.2	6182.7
36.3	6157.0
36.4	6131.5
36.5	6106.2
36.6	6080.9
36.7	6055.8
36.8	6030.7
36.9	6005.8
37.0	5981.1
37.1	5956.4
37.2	5931.8
37.3	5907.4
37.4	5883.1
37.5	5858.9
37.6	5834.8
37.7	5810.8
37.8	5786.9
37.9	5763.1
38.0	5739.5

Temp °C	Res. Ohms
38.1	5716.0
38.2	5692.5
38.3	5669.2
38.4	5646.0
38.5	5622.9
38.6	5599.9
38.7	5577.0
38.8	5554.3
38.9	5531.6
39.0	5509.0
39.1	5486.6
39.2	5464.2
39.3	5441.9
39.4	5419.8
39.5	5397.7
39.6	5375.8
39.7	5354.0
39.8	5332.2
39.9	5310.6
40.0	5289.0
40.1	5267.6
40.2	5246.2
40.3	5225.0
40.4	5203.9
40.5	5182.8
40.6	5161.9
40.7	5141.0
40.8	5120.2
40.9	5099.6
41.0	5079.0
41.1	5058.5
41.2	5038.2
41.3	5017.9
41.4	4997.7
41.5	4977.6
41.6	4957.6
41.7	4937.7
41.8	4917.9
41.9	4898.1
42.0	4878.5
42.1	4858.9

Temp °C	Res. Ohms
42.2	4839.5
42.3	4820.1
42.4	4800.8
42.5	4781.6
42.6	4762.5
42.7	4743.5
42.8	4724.5
42.9	4705.7
43.0	4686.9
43.1	4668.3
43.2	4649.7
43.3	4631.2
43.4	4612.7
43.5	4594.4
43.6	4576.1
43.7	4558.0
43.8	4539.9
43.9	4521.9
44.0	4503.9
44.1	4486.1
44.2	4468.3
44.3	4450.6
44.4	4433.0
44.5	4415.5
44.6	4398.1
44.7	4380.7
44.8	4363.4
44.9	4346.2
45.0	4329.1

Appendix B: Specifications

B.1 Power Requirements

- 10.5 A @100v ~, 50/60 Hz
- 9 A @115v ~, 50/60 Hz
- 4.5 A @ 220v ~, 50/60 Hz
- 4.5 A @ 230v ~, 50/60 Hz
- 4.5 A @ 240v ~, 50/60 Hz

Inrush for 1/2 cycle current < 80 A

Radiant Heater Element = 450-480 Watts

B.2 Accessory Outlets

- 2 A @100v ~, 50/60 Hz
- 2 A @115v ~, 50/60 Hz
- 1 A @ 220v ~, 50/60 Hz
- 1 A @ 230v ~, 50/60 Hz
- 1 A @ 240v ~, 50/60 Hz

B.3 Standards

Designed to meet requirements of

- IEC 60601-2-19 1990 with amendment 1 1996
- IEC 60601-2-21 1994 with amendment 1 1996
- IEC 60601-1 1998 with amendment 1 1991 and amendment 2 1995
- IEC 60601-1-2 2007
- 21 CFR CH-1, Section 1020.30 (N)
- UL 60601-1 2003
- CAN/CSA-C22.2 No. 601.1-M90 1990 with supplement 1 1994 and amendment 2 1998
- ISO 19054 2005 with an exception claim to clause 5.2.7.2. Slight deformation of rail occurs after application of 500N to wide surface of DIN rail.

B.4 Operating Environment

Temperature	20 to 30°C
Humidity	10 to 95% Non-condensing relative humidity

B.5 Storage Conditions

Temperature	-25 to 60°C
Humidity	5 to 95% Non-condensing relative humidity
Pressure	50 to 106 kPa

B.6 User Control Settings

Patient control temperature	35-37.5°C in 0.1°C increments
Air control temperature	20-39°C in 0.1 increments
Radiant heat power	0-100% in 5% increments
Humidity: Servo- % relative humidity	30-95% in 5% increments

B.7 Alarms

High Air Temp	1.5°C over AST (air set temperature)
Low Air Temp	3.0°C under AST
Baby Hot	1.0°C* over BST (baby set temperature)
Baby Cold	1.0°C* under BST
Fan Failure	Failure of blower system
Air Temp >3°C	>38°C for AST <37°C
Air Temp >40°C	>40°C air temperature for AST >37°C
Air Probe Failure	Compartment air probe failure
Air Probe Disconnect	Disconnection of compartment air probe
Power failure	Power switch on but no power
System failure	Non-recoverable system failure
Add Water	Humidifier water level low
Scale: Weight Exceeds Maximum	Greater than 8kg load (visual only)
Scale: Scale Failure	Detectable system failure (visual only)

* Can be re-set on the Service screen to 0.05°C

B.8 Performance

B.8.1 System

Control accuracy	$\pm 1.0^{\circ}\text{C}$	Control Temp vs. Avg. Incubator Temp with level bed in manual mode.
Variability	$\pm 0.5^{\circ}\text{C}$	Incubator Temp vs. Avg. Incubator Temp
Warm-up time	< 50 min.	Time to reach 38.5°C control temp from cold start in 25°C 50% RH room ambient
Patient measurement	$\pm 0.3^{\circ}\text{C}$ @ 30°C to 42°C	Accuracy of patient temperature accuracy measurement system within range of temperature measurement
Air Velocity	< 10 cm/sec	In Whisper Quiet™ mode, velocity measured 10 cm above the center of the mattress, closed bed
CO ₂ level	0.3%	Maximum CO ₂ level measured per IEC 60601-2-19, clause 105.1
Sound level	< 49 dbA	In Whisper Quiet™ mode, closed bed sound level measured 10 cm above the center of the mattress

B.8.2 Humidity

Servo control accuracy	$\pm 10\%$ for settings up to 85%; minimum 75% for settings >85%	Humidity control setting vs. average humidity at 10 cm above center of bed
Ramp-up time	<50 minutes	Time to reach 75% RH with a 39°C control temp from cold start in 25°C 50% RH room ambient
Operating time without refill	>12 hours	Operational time at 65% RH control setting with one filling of reservoir in 25°C 50% RH room ambient

B.8.3 Servo Control Oxygen

Control range	21 to 65% in 1% increments
Resolution	1 %
Accuracy	5%*
Rise time	10 minutes from 21% to 5% below set point
Recovery from opening porthole	5 minutes from closing porthole to 5% below set point

*Over the life of the sensor

B.9 Weight Scale

Functional range	300 g to 8 kg
Accuracy	± 10 g
Resolution	10 g (factory setting) or 5 g (for some scales only)

NOTE: For the European Union (EU) and the European Free Trade Association (EFTA) member states in Europe, check with your local regulations with respect to the Non-Automated Weighing Instrument (NAWI) directive as to the process and frequency for scale calibration. The resolution of scales distributed in this EU region vary depending on the scale revision:

- Scales with revision 2.72 only have a resolution option of 10 g.
- Scales with revision 2.86 have a resolution of 5 g up to 5000 g and 10 g up to 8000 g.

B.10 Mechanical Specifications

	Canopy Closed	Canopy Closed	Canopy Opened	Canopy Opened
	Bed Lowered	Bed Raised	Bed Lowered	Bed Raised
Maximum Height	147 cm	178 cm	208 cm	239 cm

Maximum Width	69 cm
Maximum Depth (front to back)	112 cm
Maximum Weight	129 kg

B.10.1 Accessories

	Maximum load
Storage drawer	7 kg
Monitor shelf	23 kg
Instrument shelf	9 kg
Total each accessory rail	23 kg

Appendix C: RS-232 Serial Data



WARNING:

The computer or RS-232 monitor's user program must continuously check the data link. The program should constantly verify connection to the incubator controller and check for updated data.

NOTE: In the event of a power failure, all serial communication will cease until power is restored.

C.1 RS-232 Connector

The Nurse Call and the serial data output share the same female, nine pin, d-type connector.

- Pin 2: Receive Data (incubator input)
- Pin 3: Transmit Data (incubator output)
- Pin 5: Gnd (Signal Ground)

Cable requirements

The user interface cable must have capacitance less than 1500 pF. It should be a shielded cable such as Belden 9611 with AMP shielding kit 748046-1 and ferrule 747579-8.

C.2 Data Stream

The data stream from the Giraffe products is repeated every two seconds. The RS-232 parameters are 19200bps baud rate, no parity, 8 data bits, and one stop bit. The data is in ASCII format; the string is described below.

HYB_1.40,36.1,OPEN,28.3,33.0,36.5,100,N,N,C,00,063,D,L,02043,0000,00,43,000,000,03,00

HYB	This is the product code. A "HYB" represents an OmniBed; a "INC" represents an incubator.
1.40	This is the control board software revision (thermoregulation in the startup screen).
36.1	Temperature from Patient Probe #1.
OPEN	Temperature from Patient Probe #2. "OPEN" represents no probe connected.
28.3	Air display temperature from the compartment probe.
33.0	Desired Environmental Temperature (DET). In air mode, this is also the air control temperature.
36.5	Patient control temperature.

100	Heater power.
N	Patient mode. This is either a "P" or "N."
N	Open bed mode. This is either an "O" or "N."
C	Closed bed mode. This is either an "C" or "N."
00	Set point for humidity. The "00" means the humidifier is not on.
063	Relative humidity in the infant compartment as measured by the compartment probe.
D	Boost air curtain button LED status. This is either a "D", "A" or "L". ("D" means the air curtain button LED is off. "A" means the LED is on. "L" means the fan speed is forced to low speed by the user using the air curtain button and the down arrow.)
L	Fan speed. This is either an "L" or "H."
02043	Heat sink sensor resistance. The resistance-temperature curve is located in the Tips section of the Troubleshooting chapter.
0000	Last scale weight in grams. The zeros mean that no weight was taken in this patient session.
00	Oxygen set point. If the software revision is lower than 1.42, this parameter is not shown.
43	Oxygen measurement. If the software revision is lower than 1.42, this parameter is not shown. If both "Oxygen set point" and "oxygen measurement" are 0, the GSOCS module is not installed.
000	SpO2 measurement. If the software revision is lower than 1.42, this parameter is not shown.
000	Pulse rate measurement. If the software revision is lower than 1.42, this parameter is not shown.
03	Alarms. This is the alarm code 03. If there are multiple alarms, then all of the codes will be listed here.
00	The string ends with "00".

C.3 Nurse Call

Contact ratings

- Maximum resistive load: 4 VA
- Maximum DC switching voltage: 100 Vdc
- Maximum switching current: 0.25 A
- Maximum carrying current: 0.50 A.

Connector

The Nurse Call contacts and the serial data output share the same female, nine pin, d-type connector.

Pin 6:	Closed contact under normal conditions, i.e. power on, no alarm (recommended configuration)
Pin 1:	Common contact
Pin 9:	Open contact under normal conditions, power on, no alarm These contacts are not powered. They only provide closure.

Nurse Call signals

Incubator Status	Nurse Call Signal	
	Pins 1 and 6	Pins 1 and 9
Normal	Closed	Open
Alarm	Open	Closed
Pwr switch off or pwr fails	Open	Closed
Nurse Call cable disconnected	Open	Open



World Headquarters

GE Healthcare
9900 West Innovation Drive
Wauwatosa, WI 53226-4856
USA
Tel 1 800 345 2700



EC Representative

Datex-Ohmeda Ltd.
Ohmeda House
71 Great North Road
Hatfield Hertfordshire
AL9 5EN
Tel +44 1707 263570
Fax +44 1707 260065

Europe, Middle East, Africa

GE Healthcare
P.O. Box 900
FIN-00031 GE
Finland
Tel +358 10 39411
Fax +358 9 146 3310

Germany

GE Medical Systems Information Technologies GmbH
Munzinger Str. 3-5
79111 Freiburg
Tel. 49 761 4543 570
Fax 49 761 4543 571
Service 0800 4343258

Latin America Representatives

GE Healthcare
3350 SW 148 Avenue
Suite 301
Miramar, Florida, 33027
USA
Tel + 1 954 744 5600

Asia Representative

GE Healthcare
Shanghai GE (China) Hi-tech Park
No1 Huatuo Road, Zhangjiang Hi-tech Park Pudong, Shanghai,
P.R.China 201203
上海GE中国科技园
地址: 中国上海市浦东张江高科技园华佗路1号, 201203
Tel + (8621) 38777888
Fax + (8621) 38777402

Brazil Only

GE Healthcare Clinical Sytems Equipamentos Médicos Ltda
Av. Paulista, 37 - 13º andar
CEP: 01311-902 - Cerqueira César
São Paulo, SP - Brasil
Tel +55 11 3053 2500
Fax +55 11 3053 2573

Australia	1300 722 229
China	800 810 8188
India	1 800 425 7255
Korea	(02) 1544 4564
South Eastern Asia	(65) 6277 3444

 Ohmeda Medical,
a Division of Datex-Ohmeda, Inc.,
a General Electric Company
8880 Gorman Road
Laurel MD 20723
USA



Giraffe OmniBed
Service Manual
Printed in USA
Copyright 2001 by Datex-Ohmeda, Inc.
All rights reserved.

To reorder this manual, order kit:

- 6600-0834-801 (US)
- 6600-0834-802 (INTL)

6600-0343-000
Revision 104
Language: English

Printing instructions:
Black on white
8.5" x 11" paper size
Two (2) sides print
Three (3) hole punch
Stapled or shrink wrapped