

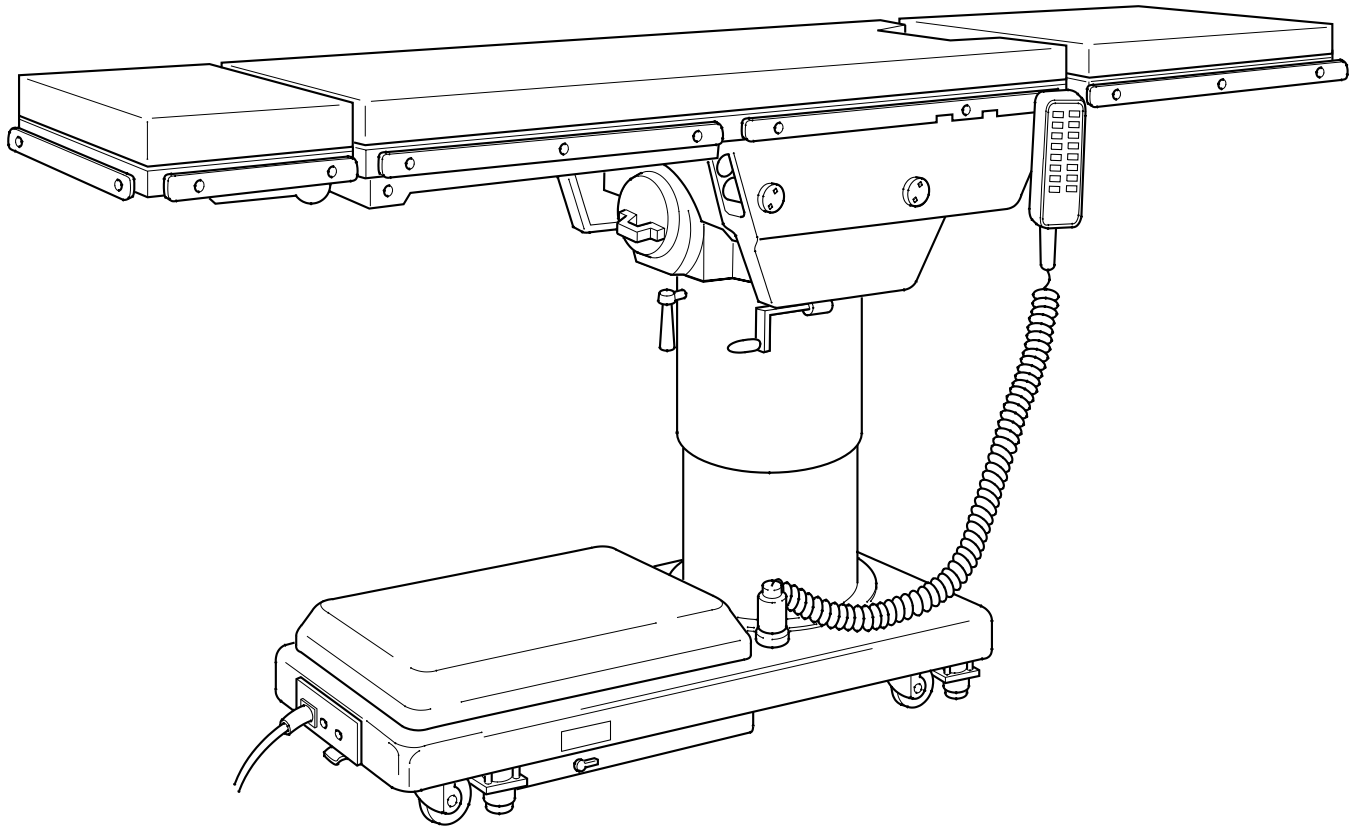

SKYTRON

TECHNICAL SERVICES

ELITE SERIES SURGICAL TABLES ***OPERATORS MANUAL***



MODEL 6000/6001
INCLUDING BATTERY MODELS

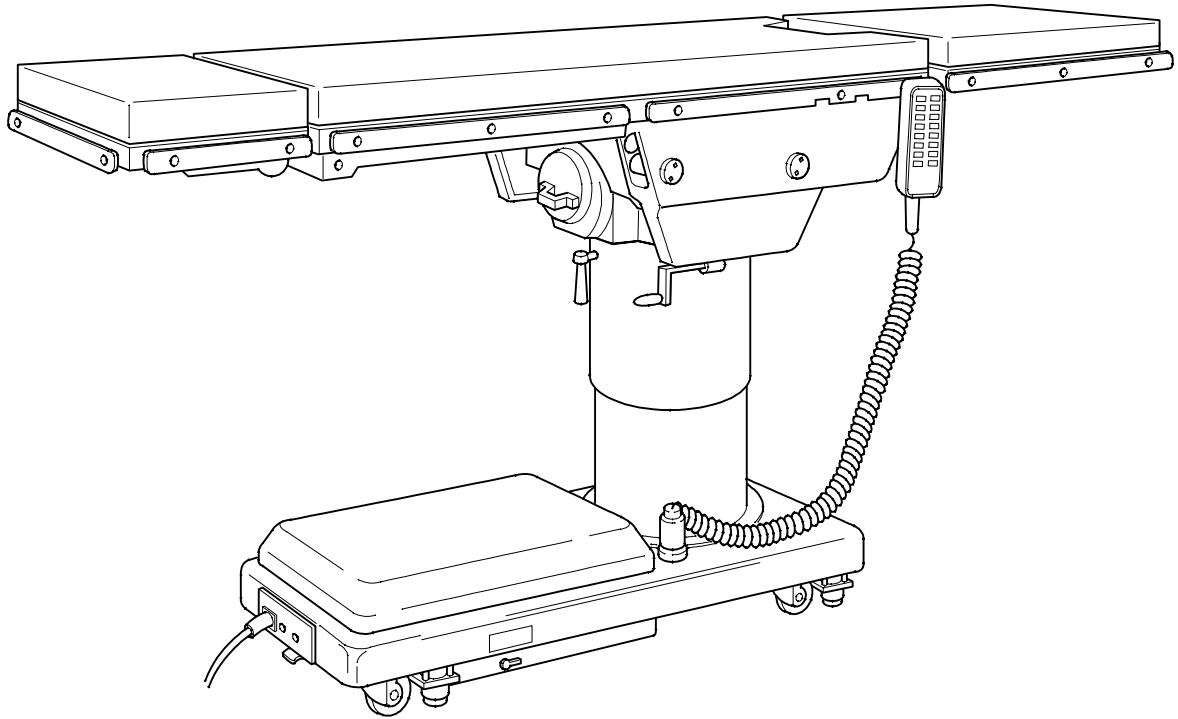

MODEL ELITE 6001K

SKYTRON STANDARD LIMITED WARRANTY

SKYTRON, a Division of the KMW Group, Inc. (SKYTRON) warrants all new products sold by it directly or through a dealer or other authorized representative, with exception to replacement parts, spares, bulbs (surgical lights), pads, and accessory items (surgical tables) to be free from defects in material or workmanship, under normal use and service, for a period of two (2) years. This warranty shall include the cost of repair or replacement of defective parts including the cost of service labor and travel time to the site of equipment use. Delays caused by the user in accessing the equipment for repair will be chargeable at the normal hourly rate for service by SKYTRON's authorized service representative. The warranty period shall begin with the initial operation or one (1) year after receipt of the product, whichever shall occur first.

Replacement parts, spares, bulbs (surgical lights), pads and accessory items (surgical tables) are warranted to be free from defects in material or workmanship, under normal use and service, for a period of ninety (90) days from receipt by the ultimate user, with exception to replacement parts supplied by SKYTRON, for products under warranty, which shall be covered for any remaining period of the original product warranty, or for 90 days, whichever is of greater benefit to the ultimate user.

SKYTRON's responsibility and liability shall be limited to the repair or replacement of any part which we, SKYTRON, determine to be defective within the applicable warranty period. Minor adjustments required as a result of normal wear during the use of the product within the warranty period are not covered under warranty. The labor portion of this warranty is covered by SKYTRON's Authorized Service Agent. Repairs made by others are not authorized nor covered by SKYTRON with respect to labor costs.

SKYTRON shall not be liable for any other expense, loss or damage, whether direct, incidental, consequential or exemplary arising in connection with the sale or use of or the inability to use SKYTRON products.

NO EXPRESS WARRANTY IS GIVEN BY SKYTRON WITH RESPECT TO ITS PRODUCTS EXCEPT AS SPECIFICALLY SET FORTH HEREIN. ANY WARRANTY IMPLIED BY LAW, INCLUDING ANY WARRANTY OF MERCHANTABILITY OR FITNESS FOR A PARTICULAR PURPOSE, IS EXPRESSLY LIMITED TO THE TWO-YEAR AND 90-DAY TERMS SET FORTH ABOVE. THE FOREGOING STATEMENTS OF WARRANTY ARE EXCLUSIVE AND IN LIEU OF ALL OTHER REMEDIES.

No dealer, agent, employee or other representative of SKYTRON is authorized to extend or enlarge this warranty.

REV. 3/97

Although current at the time of publication, SKYTRON's policy of continuous development makes this manual subject to change without notice.

TABLE OF CONTENTS

Title	Page
SPECIAL USER ATTENTION	1
SECTION I INTRODUCTION	2
1-1. General.....	2
1-2. Power Requirements	2
1-3. Pendant Control Unit	3
1-4. Floor Lock/Brake System	3
SECTION II BATTERY TABLE OPERATION	4
2-1. AC 120V Operation	4
2-2. Battery Operation	4
2-3. Automatic Shut-Off	5
2-4. Charging the Battery	5
2-5. Emergency Back-Up Controls	5
SECTION III OPERATION	6
3-1. Electrical Power	6
3-2. Positioning Functions	6
a. Floor Lock/Brake system	6
b. Emergency Brake Release	6
c. Trendelenburg	7
d. Lateral Tilt	7
e. Back Section	7
f. Elevation	8
g. Leg Section	8
h. Flex Positioning	8
i. Return To Level	8
j. Pendant Control Storage	9
3-3. Head Section	9
3-4. 180 Degree Table Top Rotation.	9
3-5. Leg Section (Elite 6000 only)	10
3-6. Kidney Lift.....	10
3-7. Specialty Positioning	11
SECTION IV MAINTENANCE	11
4-1. Preventive Maintenance	11
4-2. Service	11

SPECIAL USER ATTENTION

The extreme positioning capabilities of the 6000 Series Table requires special attention for possible interference points when using multiple function positioning. As with the operation of any surgical table, a certain amount of care should be exercised to position the patient safely. Although the thick pads and sheets substantially protect the patient, pinch points, located at the joints of the top section should always be considered. **BE SURE THAT THE ARMS, HANDS AND FINGERS OF THE PATIENT AND THOSE OF THE OPERATING ROOM PERSONNEL ARE CLEAR OF ALL MOVING PARTS BEFORE MOVING THE TABLE.** Proper restraints should always be used for patient safety.

Certain accessories such as the Uro-Drain Tray, Armboards and X-Ray top can be damaged when changing the position of the table top sections. Always look first to see if a desired movement is going to interfere with any accessories in use.

The operator has the ultimate responsibility of preventing damage to the table and surrounding equipment or possible injury to the patient or staff. In general, common sense will dictate when there is a potential hazard.

The following precautions should be reviewed by all personnel prior to operating the table.



WARNING



DO NOT use the table in the presence of **FLAMMABLE GASES** (Flammable gases are not commonly used in the U.S.).

NOTE

In case of a power failure or an electrical problem within the table, the emergency brake release system can be used to move the table. The control lever for this function is located on the side of the table base and is identified by an **EMERGENCY BRAKE RELEASE** label. Turn the lever counter-clockwise to release the brakes.



IMPORTANT



- The Emergency Brake Release Valve must be closed and tightened (clockwise) before any hydraulic function will operate.

- If the Emergency Brake Release Valve has been operated, the **UNLOCK** button on the pendant control will have to be pressed before brakes will lock again.



WARNING



DO NOT unlock brakes when a patient is on the table. An uneven patient weight load may cause instability.

NOTE

If brakes fail to set, make sure the Emergency Brake Release Lever is tight (clockwise).



IMPORTANT



The leg section may hit the table base or the floor if both the leg and elevation systems are placed in their full down position.



WARNING



Always lock the table top in position after rotation. DO NOT rotate the top with an unevenly distributed patient weight load as instability may result.



WARNING



- Make sure the **TOP ROTATION LOCK HANDLE** is tightened and the brakes are set before transferring the patient.

- Exercise caution with the table top rotated 90° to the base since an improperly distributed patient weight load may cause the table to be tipped over.

NOTE

Normal table top position is with the head (and back) section over the power cord end of the base.

NOTE

With an evenly distributed patient weight load, all table positioning functions will operate smoothly and quietly with a patient weight of up to 500 pounds.



CAUTION



To prevent damage to the kidney lift, make sure the kidney lift is completely down before raising the back section.



CAUTION



DO NOT sit on the end of the leg sections (6000 Series) as damage may result.

SECTION I INTRODUCTION

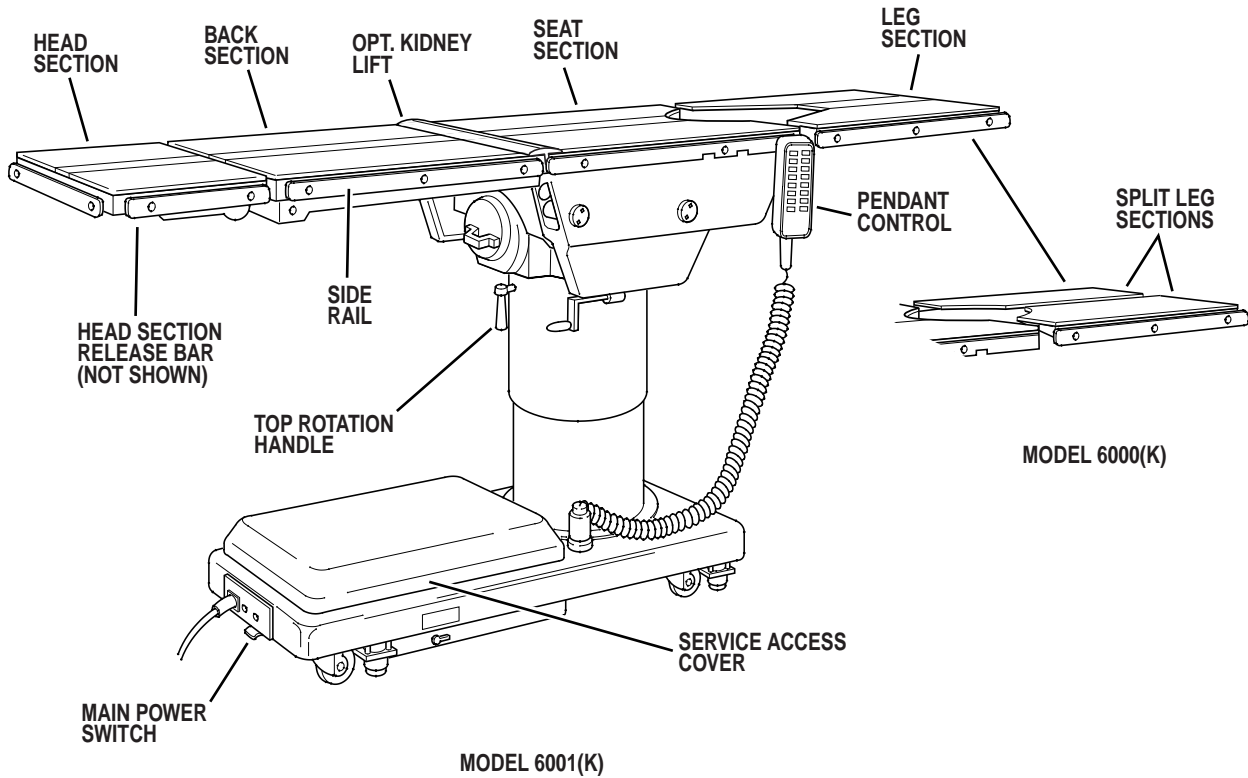

Figure 1-1. Elite 6000/6001(K)

1-1. General

SKYTRON's Elite 6000 and 6001 Series Surgical Tables are electro-hydraulically operated, general purpose surgical tables. See figure 1-1.

The two models are identical except for the leg sections. The 6000 series has manually positioned, independent, split-leg sections. The 6001 series has a single, electro-hydraulically operated leg section.

A "K" after the model number designates a built-in kidney bridge.

An "R" after the model number designates the return to level feature.

The electro-hydraulic positioning functions operated by the hand-held, push button, pendant control unit are: trendelenburg, lateral tilt, back section, elevation, leg section (6001 only), flex/reflex, return to level, and the floor lock/brake system.

Manual controls are provided for head section positioning, table top rotation, emergency brake release, leg section (6000) and kidney lift.

1-2. Power Requirements

The Elite 6000/6001 series Surgical Tables require a 120VAC, 60 Hz electrical power supply. The table is equipped with a 15 foot long power cord with a standard three prong, hospital grade plug. The electrical protection fuses are located behind a cover plate in the electrical enclosure on the front edge of the base. See figure 1-2. The main power ON/OFF switch is located on the electrical enclosure.

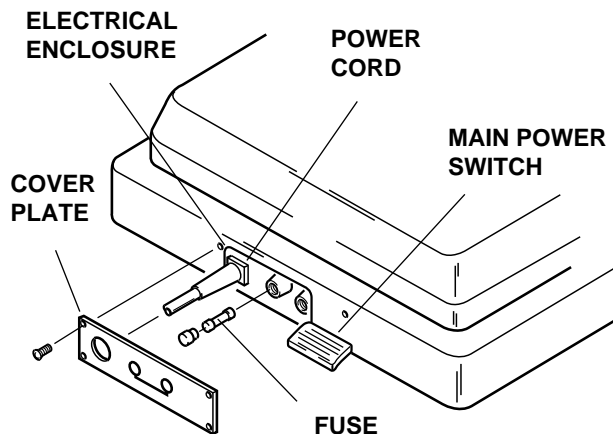

Figure 1-2. Power Switch and Fuse Location

1-3. Pendant Control Unit

The hand-held pendant control unit (figure 1-3) has a non-slip rubber cover which assures a positive grip during use. A spring clip hanger located on the back of the control allows it to be stored on the trendelenburg cylinder cap bracket or the table side rails.

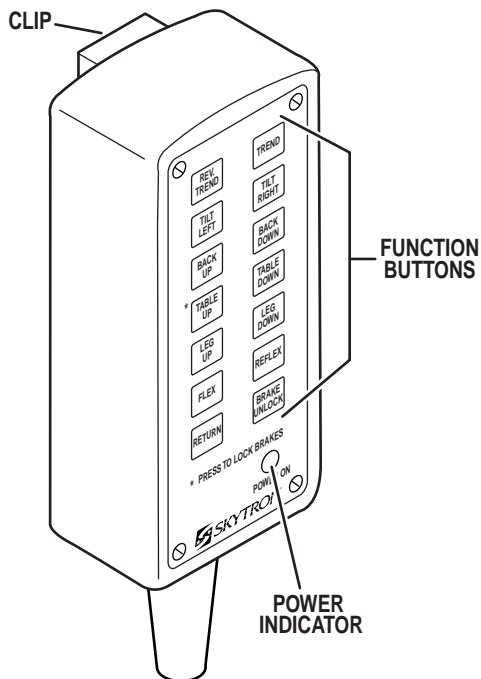

Figure 1-3. Pendant Control Unit

The function push buttons are identified with abbreviated descriptions for all functions. See figure 1-4. The trendelenburg and table up buttons are red, the remaining buttons are all black.

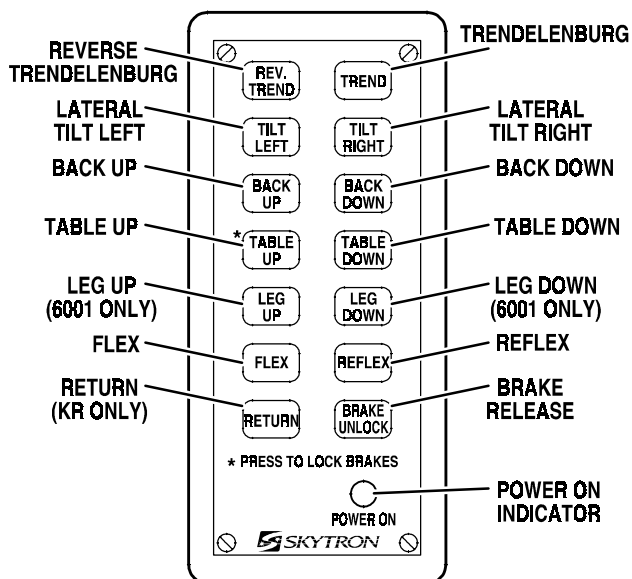

Figure 1-4. Function Push Buttons

1-4. Floor Lock/Brake System

The floor lock/brake system consists of four self-leveling, hydraulic brake cylinders which raise and support the table base off from the casters. Press the TABLE UP button on the pendant control to set the table's brakes. An electronic timer will activate the brake system until the brakes are completely set, approximately 8-10 seconds.

NOTE

Activating any function button will activate the brake system. Using the TABLE UP function to set the brakes provides a visual assurance that the brakes are locked. As the brake cylinders are extending, the entire table will move slightly. When the table top begins to elevate, the brakes are fully locked.

To unlock the brakes, press the BRAKE UNLOCK button and release. The brakes will retract automatically in approximately 7-8 seconds.



WARNING



DO NOT unlock brakes when a patient is on the table. An uneven patient weight load may cause instability.

NOTE

In case of a power failure or an electrical problem within the table, the emergency brake release system can be used to move the table. The control lever for this function is located on the side of the table base and is identified by an EMERGENCY BRAKE RELEASE label. Turn the lever counterclockwise to release the brakes.



IMPORTANT



- The Emergency Brake Release Valve must be closed and tightened (clockwise) before any hydraulic function will operate.

- If the Emergency Brake Release Valve has been operated, the BRAKE UNLOCK button on the pendant control will have to be pressed before brakes will lock again.

SECTION II BATTERY TABLE OPERATION

2-1. AC 120V Operation

a. Be sure the power cord is plugged into a properly grounded, Hospital Grade, 120VAC outlet. Make sure the power cord is routed to the outlet to prevent it from being in the way of operating personnel.

b. Depress the main power ON/OFF switch located on the electrical enclosure. See figure 2-1. The green AC 120V, Power-On indicator light located in the lower right corner of the pendant control will illuminate. See figure 2-2.

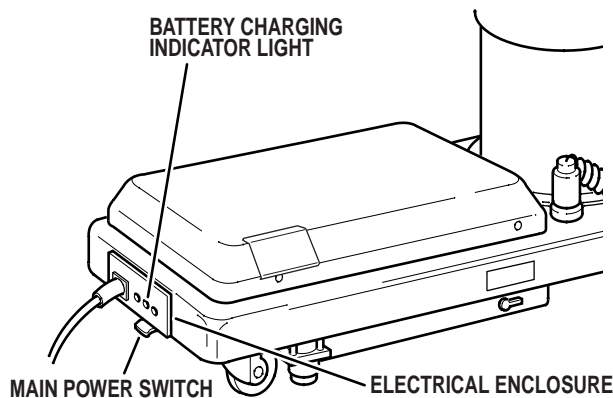

Figure 2-1. Main Power Switch

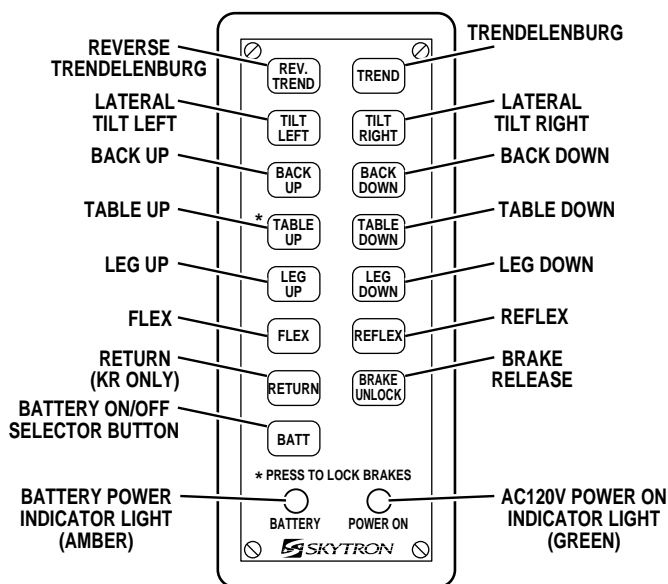

Figure 2-2. Pendant Control

c. The table is now ready for 120VAC operation. Press the TABLE UP button on the pendant control to set the table's brakes. An electronic timer will activate the brake system until the brakes are completely set, approximately 8-10 seconds. Press the desired function button to position the table.

NOTE

•If brakes fail to set, make sure the Emergency Brake Release Lever is tight (clockwise).

•If the Emergency Brake Release Valve has been operated, the BRAKE UNLOCK button on the pendant control will have to be pressed before brakes will lock again.

NOTE

•Turning the Main Power Switch ON will change the table operation to 120 VAC power regardless of the position of the BATT button.

•If Battery operation is activated while Main Power Switch is ON there will be approximately a 4 second delay before Battery operation activates.

2-2. Battery Operation

a. Make sure the green, AC 120V, Power-On indicator light, on the hand-held pendant control, is OFF. See figure 2-2. If the indicator light is ON, depress the main power ON/OFF switch, located on the electrical enclosure to turn AC120V operation OFF.

NOTE

The table will operate correctly on battery power with the power cord connected to a wall outlet or disconnected.

b. Press the BATT button on the hand-held pendant control. The amber BATTERY indicator light, located in the lower left corner of the pendant control, will illuminate. This confirms that the table is now being operated with battery power.

c. The table is now ready to operate on battery power. Press TABLE UP button on the pendant control to set the table's brakes. An electronic timer will activate the brake system until the brakes are completely set, approximately 8-10 seconds. Press desired function button to position the table.

d. To extend the battery charge life, turn the BATTERY power OFF with the pendant control when the table is not going to be used.

NOTE

Battery Operation must be turned OFF at the pendant control. It can not be turned Off using the main power switch.

2-3. Automatic Shut-Off

a. To prevent unnecessary discharge of the battery, a timer is built into the battery circuit. This timer will automatically shut the battery power OFF after 3-4 hours of table inactivity.

b. To turn the table "ON" again, simply press the BATT button on the pendant control and the amber indicator light will illuminate. Select any control button to operate the table.

2-4. Charging the Battery

a. If the battery needs to be charged when operating the table on battery power, the amber indicator light on the pendant control will begin to blink. At this time the battery needs to be re-charged.

NOTE

When the amber light starts to blink (indicating low power in battery) the table will operate for approximately 5 continuous minutes, typically long enough to use the table for the rest of the day.

b. To recharge the battery simply plug the power cord into a 120VAC wall outlet, if not already plugged in. Turn the main power ON/OFF switch ON by depressing it. The green battery charging light, located next to the power cord, will illuminate.

c. A full battery charge will last approximately 2 weeks under normal operating conditions. However, it is recommended to charge the batteries at the end of each week to establish a normal routine protocol.

NOTE

The table can be operated on 120VAC power while the battery is being re-charged. The green AC 120V indicator light (on the pendant control) will illuminate confirming 120VAC operation.

2-5. Emergency Back-up Controls

a. The emergency back-up control switches are located under the access door on the service access cover in the table base. See figure 2-3.

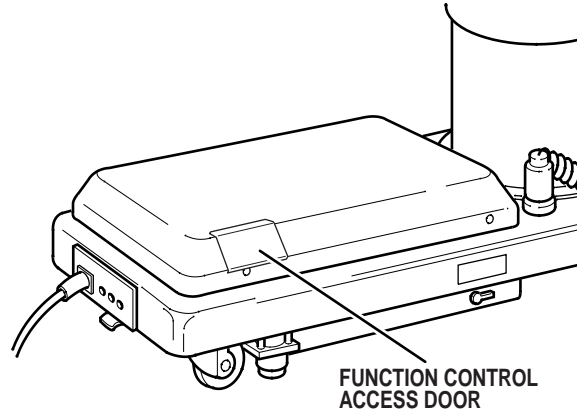

Figure 2-3. Emergency Controls Location

b. In the event of either a power failure or a problem with the hand-held pendant control, the table can be operated using the emergency back-up switches. Simply push the desired emergency switch in the appropriate direction to operate the table functions. See figure 2-4. These switches are spring-loaded so they return to the neutral or center position when released.

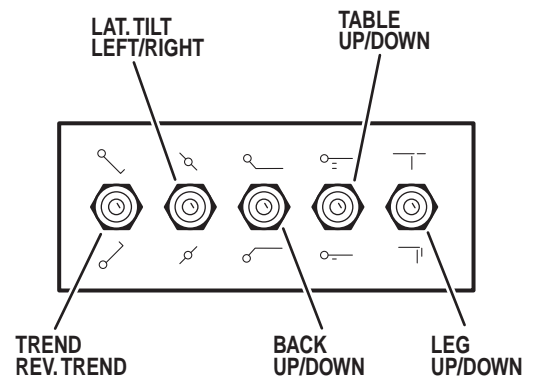

Figure 2-4. Emergency Back-Up Controls

NOTE

The emergency back-up control switches will function when the table is operating on 120VAC power, battery power, or turned off.

SECTION III OPERATION

3-1. Electrical Power

a. Check to be sure the power cord is plugged into a properly grounded, Hospital Grade, 120VAC outlet. Make sure the power cord is routed so as to prevent it from being in the way of the operating personnel.



IMPORTANT

Prior to operating the table, observe all table caution labels and review the SPECIAL USER ATTENTION section in the front of this manual.



WARNING

Possible explosion hazard exists if table is used in the presence of FLAMMABLE ANESTHETICS.

b. Depress “Main Power ON/OFF” switch on the electrical enclosure. See figure 3-1. The green POWER ON indicator light on the pendant control should now be illuminated.

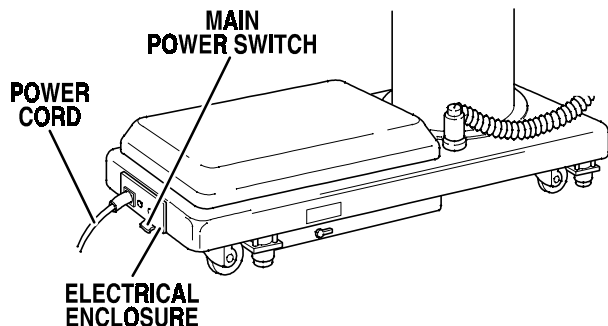

Figure 3-1. Main Power Switch

3-2. Positioning Functions

The hand-held pendant control (figure 3-2) activates the following table functions:

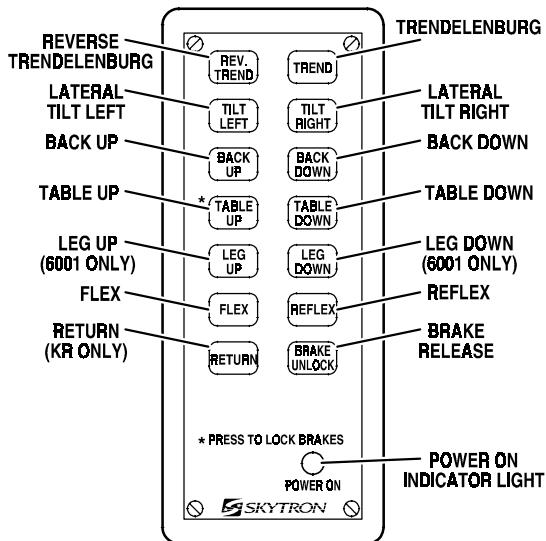

Figure 3-2. Pendant Control Unit

a. **Floor Lock/Brake System.** To activate the brakes without affecting table positioning, press the TABLE UP button. See figure 3-3. The elevation cylinder will not function until the brakes are completely extended.

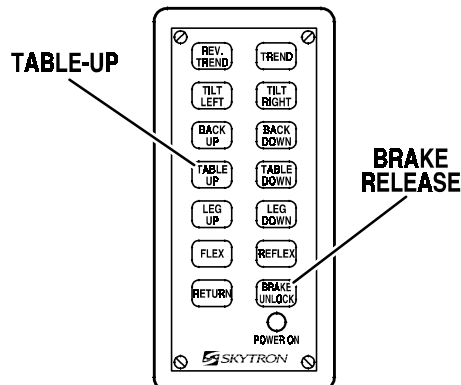

Figure 3-3. Brake System Activation

Press the BRAKE UNLOCK button on the pendant control to release the four self-leveling brake feet in order to move the table. See figure 3-3. The brake delay circuit automatically retracts the brake system with just one press of the BRAKE UNLOCK button. It takes approximately 7-8 seconds to totally release the system.



WARNING

DO NOT unlock brakes when a patient is on the table. An uneven patient weight load may cause instability.



b. **Emergency Brake Release.** In case of a power failure or an electrical problem within the table, the emergency brake release system can be used to move the table. The control lever for this function is located on the side of the table base and is identified by an EMERGENCY BRAKE RELEASE label. Turn the lever counterclockwise to release the brakes. See figure 3-4.

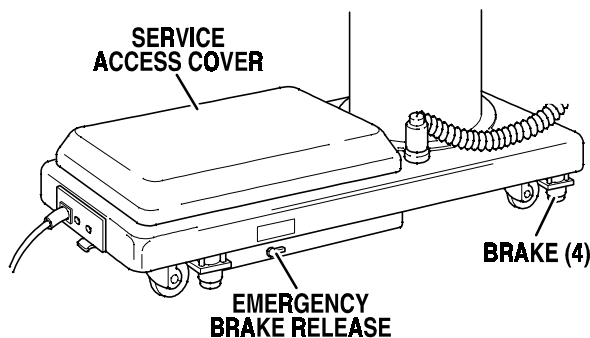

Figure 3-4. Emergency Brake Release



IMPORTANT



The Emergency Brake Release Valve must be closed and tightened (clock-wise) before any hydraulic function will operate.

- If the Emergency Brake Release Valve has been operated, the UNLOCK button on the pendant control will have to be pressed before brakes will lock again.

NOTE

With an evenly distributed patient weight load, all table positioning functions will operate smoothly and quietly with a patient weight of up to 500 pounds.

c. Trendelenburg. To place the surgical table in a trendelenburg (head down) position, press the TREND button (figure 3-5). Trendelenburg positioning of up to 30° may be obtained. To place the table in a reverse trendelenburg (head up) position, press the REV TREND button. Reverse Trendelenburg positioning of up to 30° may be obtained.



IMPORTANT



To maximize patient safety, utilize proper restraint methods during extreme trendelenburg positioning.

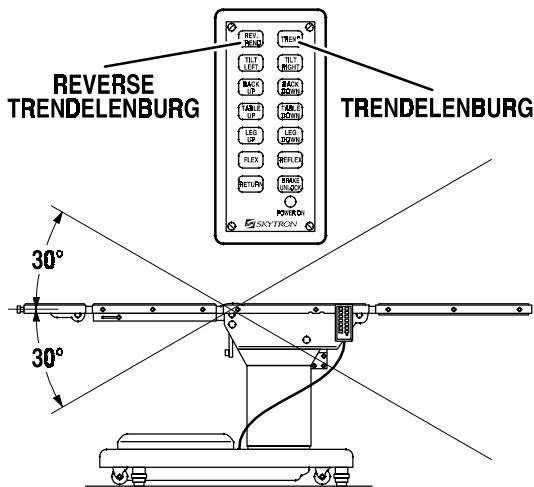

Figure 3-5. Trendelenburg Positioning

d. Lateral Tilt. To achieve lateral tilt right (as viewed from the head end of the table), press the TILT RIGHT button (figure 3-6). Tilt of up to 30° may be obtained. To achieve lateral tilt left, press the TILT LEFT button. Tilt of up to 30° may be obtained.



IMPORTANT



To maximize patient safety, utilize proper restraint methods during extreme lateral tilt positioning.

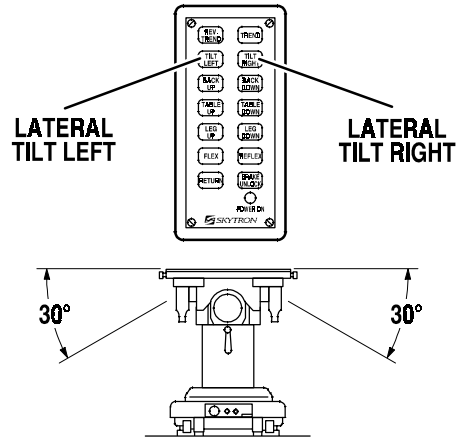

Figure 3-6. Lateral Tilt Positioning



CAUTION



To prevent damage to the kidney lift, make sure the kidney lift is completely down before raising the back section.

e. Back Section. To raise the back section, press the BACK UP button (figure 3-7). The back section will raise up to 90° above horizontal. To lower the back section, press the BACK DOWN button. The back section will go down to 40° below horizontal.

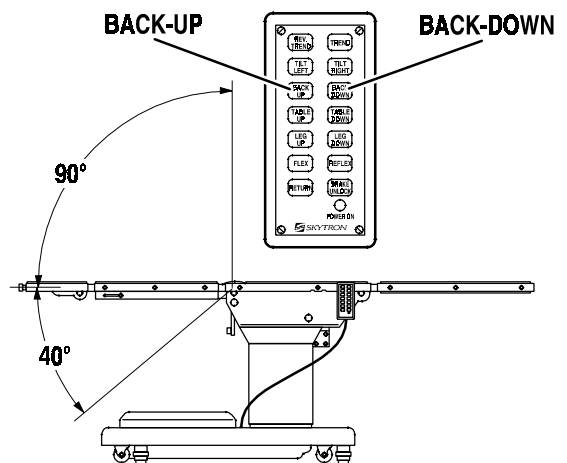

Figure 3-7. Back Section Positioning

f. Elevation. To raise table top, press the TABLE UP button (figure 3-8). The table will lift a patient weight of 500 pounds up to a maximum height of 43". To lower the table top, press the TABLE DOWN button. The table top will go down to a minimum height of 28".

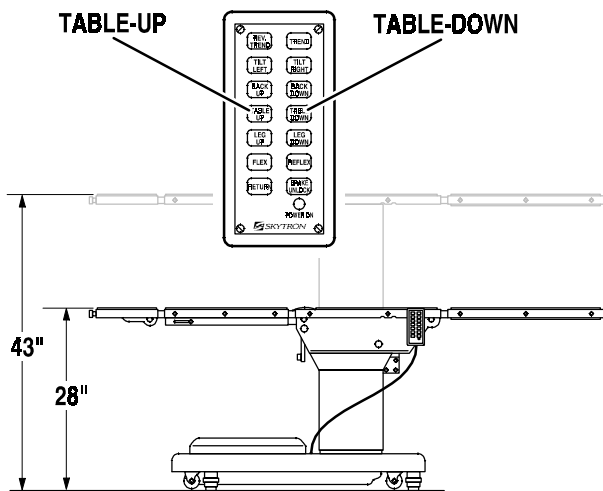

Figure 3-8. Elevation Function

g. Leg Section. To lower the leg section (6001 only), press the LEG DOWN button (figure 3-9). The leg section will go down to 105° below horizontal. To raise the leg section, press the LEG UP button. The leg section will go up to 20° above horizontal.

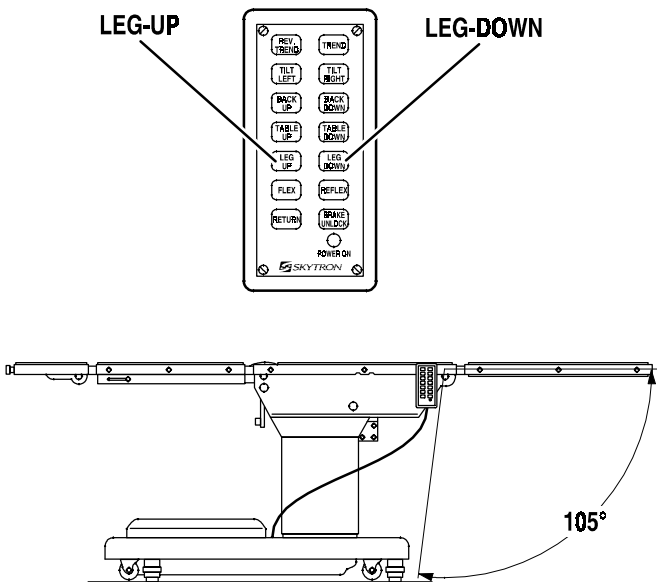

Figure 3-9. Leg Section Positioning (6001)

IMPORTANT

The Leg section may hit the table base or the floor if both the leg and elevation systems are placed in their full down position.

h. Flex Positioning. To place the table top in a flex position from horizontal, press the FLEX button (figure 3-10). To return the table top to a horizontal position or into a reflex position, press the RETURN or REFLEX button.

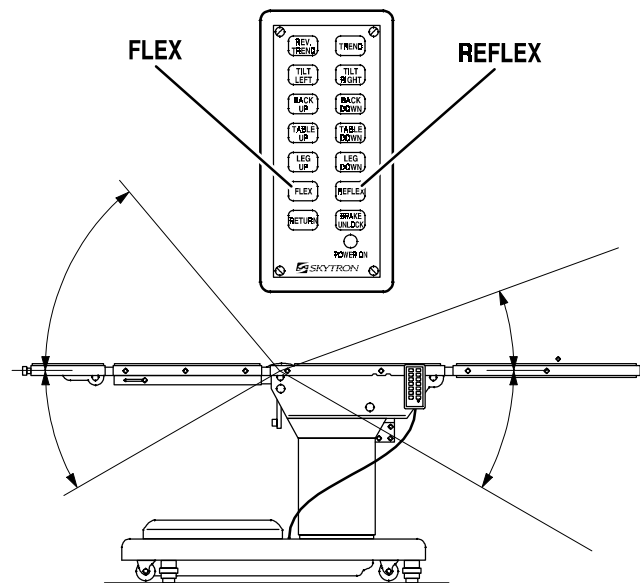

Figure 3-10. Flex/Reflex Positioning

i. Return To Level (6001KR & 6001KRB only). To return the table top to a level position, press the RETURN button (figure 3-11).

NOTE

Elevation and brake system functions are not affected by the return to level function.

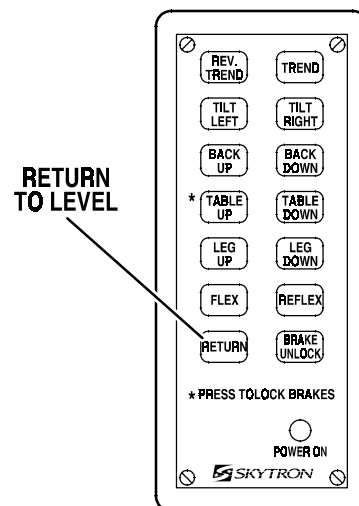

Figure 3-11. Return To Level

j. Pendant Control Storage. When the Pendant Control is not in use, it should be stored on a convenient side or end rail. A bracket is located under the table top for storage of the Pendant Control when the table is not in use and during cleaning. See figure 3-12.

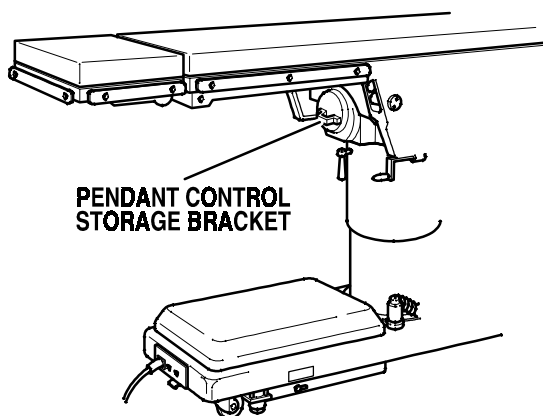

Figure 3-12. Pendant Control Storage Bracket

3-3. Head Section

a. A quick release positioning bar located under and to the front of the head section (figure 3-13) is used to raise or lower the head section. Pull the release bar toward the head end to allow the section to pivot up or down. Positioning from 60° above horizontal to 90° below horizontal in 15° increments is available. Release the bar to lock the head section in position.

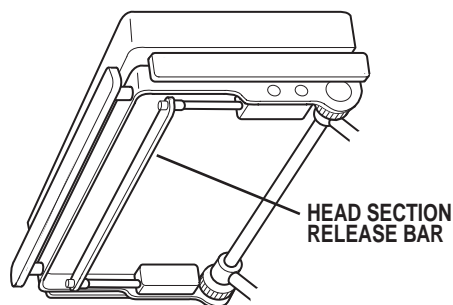

Figure 3-13. Head Section Adjustment

b. By loosening two locking knobs beneath the back section, an additional 5" of longitudinal adjustment can be achieved. If desired, the head section may be removed by loosening the locking knobs and pulling it straight out of the back section. 6001 Series Tables have the capability of attaching the head section to the leg section for use as a foot extension ONLY. Do Not reverse the patient on the table without first consulting with SKYTRON. Two locking knobs are located on the inside of the leg section for securing the head section. See figure 3-14.

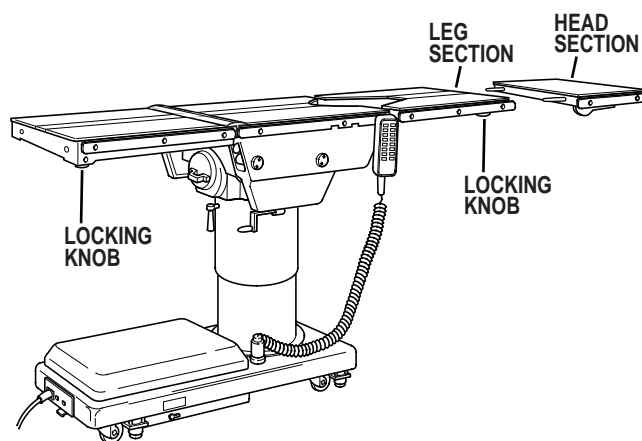

Figure 3-14. Repositioning Head Section

3-4. 180 Degree Table Top Rotation.

NOTE

Normal table top position is with the head (and back) section over the power cord end of the base.

a. The table top can be horizontally rotated 180° without having to rotate the entire table. To rotate the top, turn the TOP ROTATION LOCK HANDLE counterclockwise (figure 3-15), grasp the table by the head end and rotate the top 180° counterclockwise. Lock the top in position by tightening the TOP ROTATION LOCK HANDLE clockwise.



WARNING



Always lock the table top in position after rotation. DO NOT rotate the top with an unevenly distributed patient weight load as instability may result.

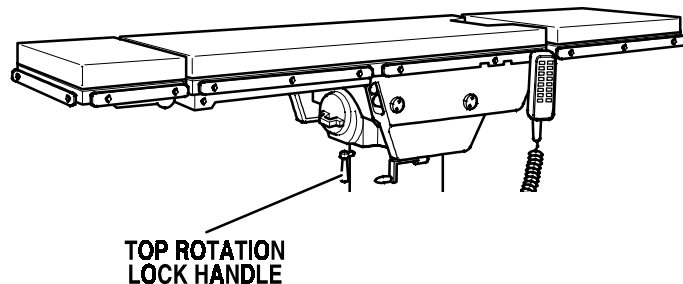

Figure 3-15. 180 Degree Top Rotation

b. The use of the optional support rod allows the table top to be rotated 90° from the base. See figure 3-16.



WARNING



- Make sure the TOP ROTATION LOCK HANDLE is tightened and the brakes are set before transferring the patient.

- Exercise caution with the table top rotated 90° to the base since an improperly distributed patient load may cause the table to be tipped over.

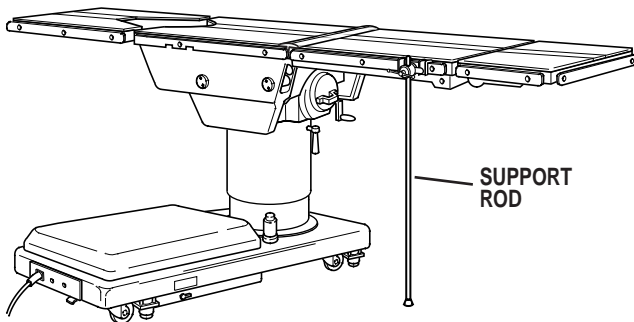

Figure 3-16. 90 Degree Top Rotation

3-5. Leg Section (Elite/6000 only)

The Elite/ 6000 series table has movable split-leg sections. The individual sections can be rotated both vertically and horizontally. To position a section vertically, lift up slightly on the leg section side rail and pull the LOCK TRIGGER outward. See figure 3-17. The positioning range is from horizontal to 105° below horizontal, in 15° increments.

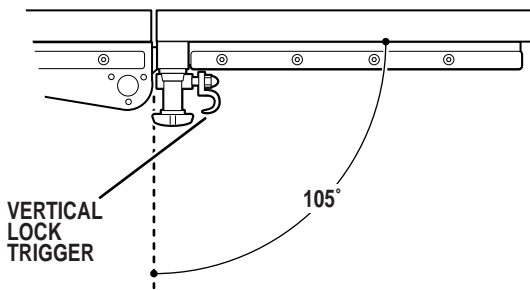

Figure 3-17. Leg Vertical Positioning

To position the leg section horizontally, loosen the LOCK HANDLE at least one full turn counterclockwise. See figure 3-18. Position the leg section as desired and tighten the LOCK HANDLE. To remove the leg section, turn the LOCK HANDLE at least five full turns counterclockwise and lift the leg section up to remove it.



CAUTION



DO NOT sit on the end of the leg sections as damage may result.

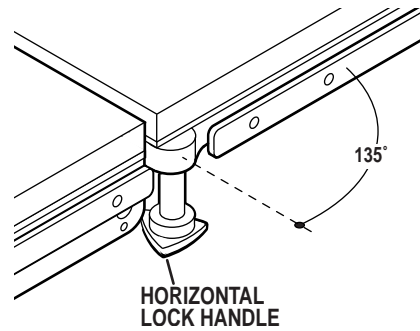

Figure 3-18. Leg Horizontal Positioning

3-6. Kidney Lift

The optional, built-in kidney lift is operated by a manual hand crank system and allows 5 inches of lift. See figure 3-19. The hand crank is stored in a bracket on the lower right hand side frame (as viewed from the head end of the table).

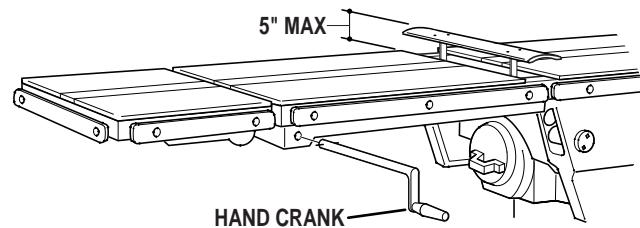

Figure 3-19. Optional Kidney Lift

To operate, connect the handle to the drive mechanism on either side of the back section. Rotate the handle clockwise to raise the lift and counterclockwise to lower it.



CAUTION



To prevent damage to the kidney lift, make sure the kidney lift is completely down before raising the back section. See figure 3-20.

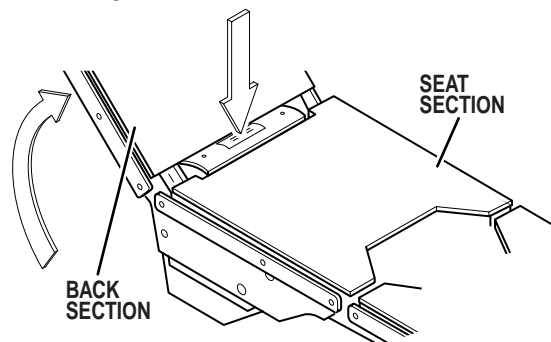

Figure 3-20.

3-7. Specialty Positioning

The use of certain optional accessories available from SKYTRON further extend the positioning capabilities of the 6000/6001 Series Tables. Refer to SKYTRON's "Positioning Guidelines" or contact your SKYTRON representative for further details.

SECTION IV MAINTENANCE

4-1. Preventive Maintenance

The following preventive maintenance checks and services are recommended to ensure the serviceability and proper operation of your SKYTRON Surgical Table.

a. During normal cleaning, a general visual examination should be made checking for leaks, loose bolts or parts, and cracked, chipped, or missing paint. Any necessary repairs should be made.

b. Semi-annually the following checks and services should be performed:

1. Check all hydraulic fittings, mini-valves and slave cylinders for proper operation and any signs of leaks.
2. Check the hydraulic speed controls and adjust if necessary.
3. Pressure check (with a gauge) the pressure relief valve.
4. Check all mechanical adjustments and adjust as necessary.
5. Check hydraulic fluid level.
6. Lubricate the slider assembly.

4-2. Service

Table maintenance can be performed by trained maintenance personnel using SKYTRON authorized replacement parts and service techniques. Service instructions and parts are available from SKYTRON.

Preventive Maintenance contracts are available through your local SKYTRON representative.

To obtain service instructions, replacement parts, factory service or preventive maintenance contracts, contact your nearest SKYTRON representative or write or call:

SKYTRON
5000 36th Street S.E.
Grand Rapids, MI 49512
1-800-SKYTRON (1-800-759-8766)
Fax. 1-616-957-5053

